

Gewindefräser Thread Milling Cutters

Seite · Page

Übersicht	Contents	326 - 327
Wegweiser und Schnittwerte	Product finder and cutting data	328 - 332
Produktseiten	Product pages	333 - 448
Technische Informationen	Technical information	449 - 472

Product Finder

v_c / f_z

M

MF

UNC
UN, UNS

UNF
UNEF

G, Rp

NPT, NPTF
Rc, W

BSW, BSF

Pg

EG (STI)
SELF-LOCK

Tr

Zubehör
Accessories

Tech. Info

BGF

ZBGF

GSF

GF

GF-KEG

ZGF

ZIRK-GF

Gigant

MoSys

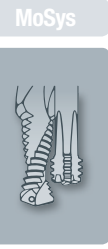

BGF



Vollhartmetall-Bohrgewindefräser

- Für die Komplettbearbeitung von Kernloch, Senkfase und Gewinde in einem Arbeitsgang
- Mit korrigiertem Gewindeprofil (abmessungsgebunden)

Solid carbide drill thread mills

- For the complete machining of thread hole, chamfer and thread in one work process
- With corrected thread profile (for one single thread size only)

333 - 352

ZBGF



Vollhartmetall-Zirkularbohrgewindefräser

- Für die Bearbeitung von Kernloch und Gewinde in einem Arbeitsgang
- Mit korrigiertem Gewindeprofil (abmessungsübergreifend, steigungsgebunden)

Solid carbide circular drill thread mills

- For the machining of thread hole and thread in one work process
- With corrected thread profile (for different thread sizes, but for one pitch only)

353 - 357

GSF



Vollhartmetall-Gewindefräser mit Senkfase

- Für die Bearbeitung von Senkfase und Gewinde in einem Arbeitsgang
- Mit korrigiertem Gewindeprofil (abmessungsgebunden)

Solid carbide thread milling cutters with countersinking step

- For the machining of countersunk edge and thread in one work process
- With corrected thread profile (for one single thread size only)

358 - 379

GSF-Z

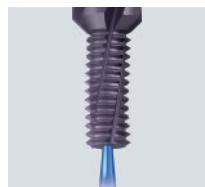

Vollhartmetall-Gewindefräser mit Senkfase

- Für die Bearbeitung von Senkfase und Gewinde in einem Arbeitsgang
- Mit korrigiertem Gewindeprofil (abmessungsgebunden)
- Hohe Nutenzahl
- Optimierte Schneidengeometrie

Solid carbide thread milling cutters with countersinking step

- For the machining of countersunk edge and thread in one work process
- With corrected thread profile (for one single thread size only)
- Increased number of flutes
- Optimised cutting geometry

GF



Vollhartmetall-Gewindefräser

- Mit Standard-Gewindeprofil (abmessungsübergreifend, steigungsgebunden)

Solid carbide thread milling cutters

- With standard thread profile (for different thread sizes, but for one pitch only)

GF-Z

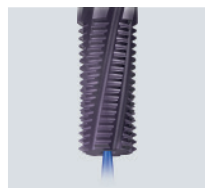

Vollhartmetall-Gewindefräser

- Mit Standard-Gewindeprofil (abmessungsübergreifend, steigungsgebunden)
- Hohe Nutenzahl
- Optimierte Schneidengeometrie

Solid carbide thread milling cutters

- With standard thread profile (for different thread sizes, but for one pitch only)
- Increased number of flutes
- Optimised cutting geometry

380 - 398

GF-Vario-Z



Vollhartmetall-Gewindefräser variabel

- Mit korrigiertem Gewindeprofil (abmessungsübergreifend, steigungsgebunden)
- Hohe Nutenzahl
- Optimierte Schneidengeometrie

Solid carbide thread milling cutters, variable

- With corrected thread profile (for different thread sizes, but for one pitch only)
- Increased number of flutes
- Optimised cutting geometry

GF-H

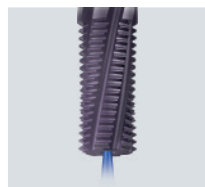

Vollhartmetall-Gewindefräser für die Hartbearbeitung

- Mit korrigiertem Gewindeprofil (abmessungsgebunden)

Solid carbide thread milling cutters for hard machining

- With corrected thread profile (for one single thread size only)

GF-KEG



Vollhartmetall-Gewindefräser für kegelige Gewinde

- Mit korrigiertem Gewindeprofil (abmessungs- bzw. steigungsgebunden)

Solid carbide thread milling cutters for tapered threads

- With corrected thread profile (for one single thread size, resp. for one pitch only)

399 - 412

ZGF



Vollhartmetall-Zirkulargewindefräser

- Mit korrigiertem Gewindeprofil (abmessungs- und steigungsübergreifend)
- Für die Bearbeitung von Gewinden ab M 1

Solid carbide circular thread milling cutters

- With corrected thread profile (for different thread sizes and pitches)
- For the machining of threads from M 1

ZGF-S-CUT



Vollhartmetall-Zirkulargewindefräser

- Mit korrigiertem Gewindeprofil (abmessungsgebunden)

Solid carbide circular thread milling cutters

- With corrected thread profile (for one single thread size only)

413 - 420

ZGF-HCUT



Vollhartmetall-Zirkulargewindefräser

- Mit korrigiertem Gewindeprofil (abmessungsgebunden)

Solid carbide circular thread milling cutters

- With corrected thread profile (for one single thread size only)

ZIRK-GF



Zirkular-Gewindefräskörper

- Mit einer oder zwei Mehrzahnplatten (abmessungsübergreifend, steigungsgebunden)

Circular thread milling bodies

- With one or two multi-tooth inserts (for different thread sizes, but for one pitch only)

421 - 425

ZIRK-GF



Zirkular-Gewindefräskörper

- Mit Einstechwendeplatte „3-Zahn“ (abmessungs- und steigungsübergreifend)

Circular thread milling bodies

- With infeed indexable insert "3-tooth" (for different thread sizes and pitches)

Gigant

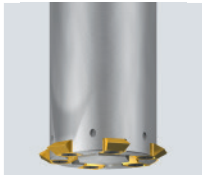

Zirkular-Gewindefräskörper

- Speziell für große Abmessungen
- Mit bis zu zehn 4-Zahn-Wendeplatten (abmessungs- und steigungsübergreifend)

Circular thread milling bodies

- Specially made for large thread sizes
- With up to ten 4-tooth indexable inserts (for different thread sizes and pitches)

426 - 445

MoSys

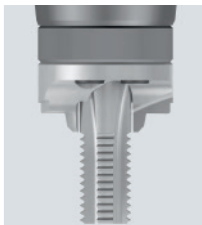

Kombinierbares Plan- und Stufsenk-System

- Für die Komplettbearbeitung von z.B. Bohrung, Gewinde und Plansenkung

Counterbore and stepped bore system for free combination

- For the complete machining of thread hole, thread and spot face

446 - 448

v_c / f_z

M

MF

UNC
UN, UNS

UNF
UNEF

G, Rp

NPT, NPTF
Rc, W

BSW, BSF

Pg

EG (STI)
SELF-LOCK

Tr

Zubehör
Accessories

Tech. Info

BGF

ZBGF

GSF

GF

GF-KEG

ZGF

ZIRK-GF

Gigant

MoSys



Wegweiser und Schnittwerte

Bitte beachten:

Die in den jeweiligen Spalten angegebenen Schnittwerte sind Richtwerte, welche je nach Einsatzbedingungen (Material, Schmierung, Maschine, usw.) angepasst werden müssen.

Die Eignung ist folgendermaßen gekennzeichnet:

- Gewindefräser sehr gut geeignet
- Gewindefräser gut geeignet

v_c = Schnittgeschwindigkeit [m/min]

f_z = Vorschub pro Zahn [mm]

f_b = Vorschub beim Bohren [mm/U]

Product finder and cutting data

Please note:

The cutting values listed in the respective columns are standard values which have to be adjusted to individual work conditions (material, lubrication, machine etc.).

The suitability is marked as follows:

- Thread milling cutter is very suitable
- Thread milling cutter is suitable

v_c = Cutting speed [m/min]

f_z = Feed per tooth [mm]

f_b = Drilling feed [mm/U]

Internationaler Werkstoffvergleich siehe Seite 838 - 851.

International comparison of materials, see page 838 - 851.

Einsatzgebiete – Material Applications – material		Material-Beispiele Material examples	Material-Nummern Material numbers
P	Stahlwerkstoffe Kaltfließpressstähle, Baustähle, Automatenstähle, u.a.	Steel materials Cold-extrusion steels, Construction steels, Free-cutting steels, etc.	Cq15 1.1132 S235JR (St37-2) 1.0037 10SPb20 1.0722
	2.1 Baustähle, Einsatzstähle, Stahlguss, u.a.	Construction steels, Cementation steels, Steel castings, etc.	E360 (St70-2) 1.0070 16MnCr5 1.7131 GS-25CrMo4 1.7218
	3.1 Einsatzstähle, Vergütungsstähle, Kaltarbeitsstähle, u.a.	Cementation steels, Heat-treatable steels, Cold work steels, etc.	20MoCr3 1.7320 42CrMo4 1.7225 102Cr6 1.2067 50CrMo4 1.7228
	4.1 Vergütungsstähle, Kaltarbeitsstähle, Nitrierstähle, u.a.	Heat-treatable steels, Cold work steels, Nitriding steels, etc.	X45NiCrMo4 1.2767 31CrMo12 1.8515 X38CrMoV5-3 1.2367
	5.1 Hochlegierte Stähle, Kaltarbeitsstähle, Warmarbeitsstähle, u.a.	High-alloyed steels, Cold work steels, Hot work steels, etc.	X100CrMoV8-1-1 1.2990 X40CrMoV5-1 1.2344
M	Nichtrostende Stahlwerkstoffe 1.1 Ferritisch, martensitisch	Stainless steel materials Ferritic, martensitic	X2CrTi12 1.4512
	2.1 Austenitisch	Austenitic	X6CrNiMoTi17-12-2 1.4571
	3.1 Austenitisch-ferritisch (Duplex)	Austenitic-ferritic (Duplex)	X2CrNiMoN22-5-3 1.4462
	4.1 Austenitisch-ferritisch hitzebeständig (Super Duplex)	Austenitic-ferritic heat-resistant (Super Duplex)	X2CrNiMoN25-7-4 1.4410
K	Gusswerkstoffe 1.1 Gusseisen mit Lamellengrafit (GJL)	Cast materials Cast iron with lamellar graphite (GJL)	EN-GJL-200 (GG20) EN-JL-1030
	1.2 Gusseisen mit Kugelgrafit (GJS)	Cast iron with nodular graphite (GJS)	250-450 N/mm ² EN-GJL-300 (GG30) EN-JL-1050
	2.1 Gusseisen mit Kugelgrafit (GJS)	Cast iron with nodular graphite (GJS)	350-500 N/mm ² EN-GJS-400-15 (GGG40) EN-JS-1030
	2.2 Gusseisen mit Kugelgrafit (GJS)	Cast iron with nodular graphite (GJS)	500-900 N/mm ² EN-GJS-700-2 (GGG70) EN-JS-1070
	3.1 Gusseisen mit Vermiculargrafit (GJV)	Cast iron with vermicular graphite (GJV)	300-400 N/mm ² GJV 300
	3.2 Gusseisen mit Vermiculargrafit (GJV)	Cast iron with vermicular graphite (GJV)	400-500 N/mm ² GJV 450
4.1 Temperguss (GTMW, GTMB)	Malleable cast iron (GTMW, GTMB)	250-500 N/mm ² EN-GJMW-350-4 (GTW-35) EN-JM-1010	
4.2 Temperguss (GTMW, GTMB)	Malleable cast iron (GTMW, GTMB)	500-800 N/mm ² EN-GJMB-450-6 (GTS-45) EN-JM-1140	
N	Nichteisenwerkstoffe 1.1 Aluminium-Legierungen	Non ferrous materials Aluminium alloys	
	1.2 Aluminium-Knetlegierungen	Aluminium wrought alloys	EN AW-AlMn1 EN AW-3103 EN AW-AlMgSi EN AW-6060
	1.3 Aluminium-Knetlegierungen	Aluminium wrought alloys	EN AW-AlZn5Mg3Cu EN AW-7022
	1.4 Aluminium-Knetlegierungen	Aluminium wrought alloys	Si ≤ 7% EN AC-AlMg5 EN AC-307 G
	1.5 Aluminium-Gusslegierungen	Aluminium cast alloys	7% < Si ≤ 12% EN AC-AISi9Cu3 EN AC-46500
	1.6 Aluminium-Gusslegierungen	Aluminium cast alloys	12% < Si ≤ 17% GD-AISi17Cu4FeMg
	2.1 Reinkupfer, niedriglegiertes Kupfer	Pure copper, low-alloyed copper	E-Cu 57 EN CW 004 A
	2.2 Kupfer-Zink-Legierungen (Messing, langspanend)	Copper-zinc alloys (brass, long-chipping)	CuZn37 (Ms63) EN CW 508 L
	2.3 Kupfer-Zink-Legierungen (Messing, kurzspanend)	Copper-zinc alloys (brass, short-chipping)	CuZn36Pb3 (Ms58) EN CW 603 N
	2.4 Kupfer-Aluminium-Legierungen (Alubronze, langspanend)	Copper-aluminium alloys (alu bronze, long-chipping)	CuAl10Ni5Fe4 EN CW 307 G
	2.5 Kupfer-Zinn-Legierungen (Zinnbronze, langspanend)	Copper-tin alloys (tin bronze, long-chipping)	CuSn8P EN CW 459 K
	2.6 Kupfer-Zinn-Legierungen (Zinnbronze, kurzspanend)	Copper-tin alloys (tin bronze, short-chipping)	CuSn7 ZnPb (Rg7) 2.1090
	2.7 Kupfer-Sonderlegierungen	Special copper alloys	AMPCO® 8
	2.8 Kupfer-Sonderlegierungen	Special copper alloys	AMPCO® 45
	3.1 Magnesium-Knetlegierungen	Magnesium wrought alloys	MgAl6Zn 3.5612
	3.2 Magnesium-Gusslegierungen	Magnesium cast alloys	EN-MCMgAl9Zn1 EN-MC21120
S	Kunststoffe 4.1 Duroplaste (kurzspanend)	Synthetics Duroplastics (short-chipping)	Bakelit, Pertinax
	4.2 Thermoplaste (langspanend)	Thermoplastics (long-chipping)	PMMA, POM, PVC
	4.3 Faserverstärkte Kunststoffe (Faseranteil ≤ 30%)	Fibre-reinforced synthetics (fibre content ≤ 30%)	GFK, CFK, AFK
	4.4 Faserverstärkte Kunststoffe (Faseranteil > 30%)	Fibre-reinforced synthetics (fibre content > 30%)	GFK, CFK, AFK
	Besondere Werkstoffe 5.1 Graphit	Special materials Graphite	C 8000
	5.2 Wolfram-Kupfer-Legierungen	Tungsten-copper alloys	W-Cu 80/20
	5.3 Verbundwerkstoffe	Composite materials	Hyllite, Alucobond
	Spezialwerkstoffe Titan-Legierungen	Special materials Titanium alloys	
	1.1 Reintitan	Pure titanium	Ti1 3.7025
	1.2 Titan-Legierungen	Titanium alloys	TiAl6V4 3.7165
1.3 Titan-Legierungen	Titanium alloys	TiAl4Mo4Sn2 3.7185	
S	Nickel-, Kobalt- und Eisen-Legierungen 2.1 Reinnickel	Nickel alloys, cobalt alloys and iron alloys Pure nickel	Ni 99.6 2.4060
	2.2 Nickel-Basis-Legierungen	Nickel-base alloys	Monel 400 2.4360
	2.3 Nickel-Basis-Legierungen	Nickel-base alloys	Inconel 718 2.4668
	2.4 Kobalt-Basis-Legierungen	Cobalt-base alloys	Udimet 605
	2.5 Kobalt-Basis-Legierungen	Cobalt-base alloys	Haynes 25 2.4964
	2.6 Eisen-Basis-Legierungen	Iron-base alloys	Incoloy 800 1.4958
H	Harte Werkstoffe 1.1 Hochfeste Stähle, gehärtete Stähle, Hartguss	Hard materials High strength steels, hardened steels, hard castings	Weldox 1100 Hardox 550 Armax 600T Ferro-Titanit HSSE
	1.2 Hochfeste Stähle, gehärtete Stähle, Hartguss	High strength steels, hardened steels, hard castings	
	1.3 Hochfeste Stähle, gehärtete Stähle, Hartguss	High strength steels, hardened steels, hard castings	
	1.4 Hochfeste Stähle, gehärtete Stähle, Hartguss	High strength steels, hardened steels, hard castings	
	1.5 Hochfeste Stähle, gehärtete Stähle, Hartguss	High strength steels, hardened steels, hard castings	



GSF, GSF-Z



GF, GF-Z



GF-Vario-Z



GF-KEG



ZIRK-GF



GF-H

gerade- und 15° drallgenutet (R15)
straight flutes and 15° spiral flutes (R15)

30° drallgenutet (R30)
30° spiral flutes (R30)

v_c		v_c		f_z			v_c	f_z	
Unbeschichtet Uncoated	TICN	Unbeschichtet Uncoated	TICN	$\phi d_1 \leq 4 \text{ mm}$	$\phi d_1 \leq 8 \text{ mm}$	$\phi d_1 > 8 \text{ mm}$	TICN		
40 - 100	80 - 250	40 - 100	80 - 250	0,005 - 0,04	0,04 - 0,07	0,05 - 0,15			1.1
30 - 80	60 - 150	30 - 80	60 - 150	0,005 - 0,04	0,04 - 0,07	0,05 - 0,15			2.1
20 - 60	40 - 120	20 - 60	40 - 120	0,005 - 0,03	0,03 - 0,05	0,04 - 0,12			3.1
20 - 60	40 - 120			0,003 - 0,02	0,02 - 0,05	0,04 - 0,12			4.1
20 - 60	40 - 120			0,003 - 0,02	0,02 - 0,05	0,04 - 0,12			5.1
	40 - 120		40 - 120	0,003 - 0,03	0,03 - 0,05	0,04 - 0,12			1.1
	40 - 120		40 - 120	0,003 - 0,03	0,03 - 0,05	0,04 - 0,12			2.1
	30 - 80			0,003 - 0,02	0,02 - 0,05	0,04 - 0,10			3.1
	30 - 60			0,003 - 0,02	0,02 - 0,04	0,03 - 0,08			4.1
80 - 140	100 - 200	80 - 140	100 - 200		0,04 - 0,07	0,05 - 0,15			1.1
80 - 140	100 - 200	80 - 140	100 - 200		0,04 - 0,07	0,05 - 0,15			1.2
60 - 120	80 - 200	60 - 120	80 - 200		0,04 - 0,07	0,05 - 0,15			2.1
60 - 120	80 - 200	60 - 120	80 - 200		0,04 - 0,07	0,05 - 0,15			2.2
60 - 120	80 - 200	60 - 120	80 - 200		0,04 - 0,07	0,05 - 0,15			3.1
60 - 120	80 - 200	60 - 120	80 - 200		0,04 - 0,07	0,05 - 0,15			3.2
60 - 120	80 - 200	60 - 120	80 - 200		0,04 - 0,07	0,05 - 0,15			4.1
60 - 120	80 - 200	60 - 120	80 - 200		0,04 - 0,07	0,05 - 0,15			4.2
100 - 250	150 - 400	100 - 250	150 - 400	0,01 - 0,05	0,05 - 0,08	0,07 - 0,20			1.1
100 - 250	150 - 400	100 - 250	150 - 400	0,01 - 0,05	0,05 - 0,08	0,07 - 0,20			1.2
100 - 250	150 - 400	100 - 250	150 - 400	0,01 - 0,05	0,05 - 0,08	0,07 - 0,20			1.3
100 - 250	150 - 400	100 - 250	150 - 400	0,01 - 0,05	0,05 - 0,08	0,07 - 0,20			1.4
150 - 250	150 - 400	150 - 250	150 - 400	0,01 - 0,05	0,05 - 0,08	0,07 - 0,20			1.5
	100 - 200		100 - 200	0,01 - 0,05	0,05 - 0,08	0,07 - 0,20			1.6
100 - 250	150 - 400	100 - 250	150 - 400	0,008 - 0,05	0,05 - 0,08	0,07 - 0,20			2.1
100 - 250	150 - 400	100 - 250	150 - 400	0,008 - 0,05	0,05 - 0,08	0,07 - 0,20			2.2
100 - 250	150 - 400	100 - 250	150 - 400	0,008 - 0,05	0,05 - 0,08	0,07 - 0,20			2.3
60 - 150	100 - 250	60 - 150	100 - 250	0,008 - 0,04	0,04 - 0,07	0,05 - 0,15			2.4
60 - 150	100 - 250	60 - 150	100 - 250	0,008 - 0,04	0,04 - 0,07	0,05 - 0,15			2.5
60 - 150	100 - 250	60 - 150	100 - 250	0,008 - 0,04	0,04 - 0,07	0,05 - 0,15			2.6
80 - 200	100 - 250	80 - 200	100 - 250	0,008 - 0,04	0,04 - 0,07	0,05 - 0,15			2.7
	40 - 80		40 - 80	0,003 - 0,02	0,02 - 0,05	0,04 - 0,15	40 - 60	0,008 - 0,03	2.7
	30 - 60			0,003 - 0,02	0,02 - 0,05	0,04 - 0,15	40 - 60	0,008 - 0,03	2.8
150 - 250	150 - 400	150 - 250	150 - 400	0,01 - 0,05	0,05 - 0,08	0,07 - 0,20			3.1
150 - 250	150 - 400	150 - 250	150 - 400	0,01 - 0,05	0,05 - 0,08	0,07 - 0,20			3.2
60 - 150	100 - 400	60 - 150	100 - 400	0,01 - 0,05	0,05 - 0,10	0,08 - 0,25			4.1
60 - 150	100 - 400	60 - 150	100 - 400	0,01 - 0,05	0,05 - 0,10	0,08 - 0,25			4.2
	80 - 120		80 - 120	0,01 - 0,05	0,05 - 0,10	0,08 - 0,25			4.3
	80 - 120		80 - 120	0,01 - 0,05	0,05 - 0,10	0,08 - 0,25			4.4
	100 - 200		100 - 200		0,04 - 0,07	0,08 - 0,25			5.1
15 - 40	30 - 60	15 - 40	30 - 60		0,02 - 0,04	0,03 - 0,08			5.2
									5.3
15 - 50	30 - 80	15 - 50	30 - 80	0,003 - 0,03	0,03 - 0,05	0,04 - 0,10			1.1
15 - 50	30 - 80	15 - 50	30 - 80	0,003 - 0,03	0,03 - 0,05	0,04 - 0,10			1.2
15 - 40	30 - 60			0,003 - 0,02	0,02 - 0,04	0,03 - 0,08			1.3
	30 - 60		30 - 60	0,003 - 0,02	0,02 - 0,04	0,03 - 0,08			2.1
	30 - 60			0,003 - 0,02	0,02 - 0,04	0,03 - 0,08			2.2
	30 - 40			0,003 - 0,02	0,02 - 0,04	0,03 - 0,08			2.3
	30 - 60			0,003 - 0,02	0,02 - 0,04	0,03 - 0,08			2.4
	30 - 40			0,003 - 0,02	0,02 - 0,04	0,03 - 0,08			2.5
	30 - 40			0,003 - 0,02	0,02 - 0,04	0,03 - 0,08			2.6
	30 - 60				0,015 - 0,04	0,03 - 0,08			1.1
	30 - 60				0,015 - 0,04	0,03 - 0,08			1.2
							40 - 60	0,005 - 0,025	1.3
							30 - 40	0,005 - 0,015	1.4
							30 - 40	0,005 - 0,015	1.5

Product Finder

v_c / f_z

M

MF

UNC
UN, UNS

UNF
UNEF

G, Rp

NPT, NPTF
Rc, W

BSW, BSF

Pg

EG (STI)
SELF-LOCK

Tr

Zubehör
Accessories

Tech. Info

BGF

ZBGF

GSF

GF

GF-KEG

ZGF

ZIRK-GF

Gigant

MoSys



BGF-Z2



BGF-Z3



BGF-Z4

	v_c		v_c		v_c		f_b		f_z		
	Unbeschichtet Uncoated	TICN	Unbeschichtet Uncoated	TICN	TICN	TIALN-T3	$\varnothing d_1 \leq 8 \text{ mm}$	$\varnothing d_1 > 8 \text{ mm}$	$\varnothing d_1 \leq 8 \text{ mm}$	$\varnothing d_1 > 8 \text{ mm}$	
P	1.1										
	2.1										
	3.1										
	4.1										
	5.1										
M	1.1										
	2.1										
	3.1										
	4.1										
K	1.1	80 - 140	80 - 160	80 - 140	80 - 160	80 - 160	80 - 160	0,10 - 0,25	0,20 - 0,40	0,04 - 0,07	0,05 - 0,12
	1.2	80 - 140	80 - 160	80 - 140	80 - 160	80 - 160	80 - 160	0,10 - 0,25	0,20 - 0,40	0,04 - 0,07	0,05 - 0,12
	2.1	80 - 140	80 - 160					0,10 - 0,15	0,15 - 0,25	0,04 - 0,07	0,05 - 0,12
	2.2	80 - 140	80 - 160					0,10 - 0,15	0,15 - 0,25	0,04 - 0,07	0,05 - 0,12
	3.1	80 - 140	80 - 160					0,10 - 0,25	0,20 - 0,40	0,04 - 0,07	0,05 - 0,12
	3.2	80 - 140	80 - 160					0,10 - 0,25	0,20 - 0,40	0,04 - 0,07	0,05 - 0,12
	4.1										
4.2											
N	1.1	100 - 250	150 - 250					0,08 - 0,15	0,15 - 0,25	0,04 - 0,08	0,07 - 0,15
	1.2	100 - 250	150 - 250					0,08 - 0,15	0,15 - 0,25	0,04 - 0,08	0,07 - 0,15
	1.3	100 - 250	150 - 250					0,08 - 0,15	0,15 - 0,25	0,04 - 0,08	0,07 - 0,15
	1.4	100 - 250	150 - 400					0,15 - 0,25	0,20 - 0,40	0,04 - 0,08	0,07 - 0,15
	1.5	100 - 250	150 - 400	100 - 250	150 - 400	150 - 400	150 - 400	0,15 - 0,25	0,20 - 0,40	0,04 - 0,08	0,07 - 0,15
	1.6		100 - 200		100 - 200	100 - 200	100 - 200	0,15 - 0,25	0,20 - 0,40	0,04 - 0,08	0,07 - 0,15
	2.1										
	2.2	100 - 250	150 - 400					0,10 - 0,20	0,15 - 0,30	0,05 - 0,08	0,07 - 0,15
	2.3	100 - 250	150 - 400	100 - 250	150 - 400	150 - 400	150 - 400	0,10 - 0,20	0,15 - 0,30	0,05 - 0,08	0,07 - 0,15
	2.4										
	2.5										
	2.6	80 - 200	100 - 250					0,10 - 0,25	0,20 - 0,40	0,04 - 0,07	0,05 - 0,12
	2.7										
	2.8										
	3.1	100 - 250	150 - 400					0,10 - 0,20	0,15 - 0,30	0,04 - 0,08	0,07 - 0,15
	3.2	100 - 250	150 - 400					0,15 - 0,30	0,20 - 0,40	0,04 - 0,08	0,07 - 0,15
4.1	60 - 150	100 - 400					0,15 - 0,30	0,20 - 0,40	0,05 - 0,10	0,08 - 0,20	
4.2											
4.3											
4.4											
5.1											
5.2											
5.3											
S	1.1										
	1.2										
	1.3										
	2.1										
	2.2										
	2.3										
H	1.1										
	1.2										
	1.3										
	1.4										
	1.5										



ZGF



ZGF-S-CUT



ZGF-HCUT

	v_c		f_z			v_c	f_z	
	Unbeschichtet Uncoated	TiCN	$\varnothing d_1 \leq 4 \text{ mm}$	$\varnothing d_1 \leq 8 \text{ mm}$	$\varnothing d_1 > 8 \text{ mm}$			
40 - 100	80 - 250		0,005 - 0,04	0,04 - 0,07	0,05 - 0,15			1.1
30 - 80	60 - 150		0,005 - 0,04	0,04 - 0,07	0,05 - 0,15			2.1
20 - 60	40 - 120		0,005 - 0,03	0,03 - 0,05	0,04 - 0,12			3.1
20 - 60	40 - 120		0,003 - 0,02	0,02 - 0,05	0,04 - 0,12			4.1
20 - 60	40 - 120		0,003 - 0,02	0,02 - 0,05	0,04 - 0,12			5.1
	40 - 120		0,003 - 0,03	0,03 - 0,05	0,04 - 0,12			1.1
	40 - 120		0,003 - 0,03	0,03 - 0,05	0,04 - 0,12			2.1
	30 - 80		0,003 - 0,02	0,02 - 0,05	0,04 - 0,10			3.1
	30 - 60		0,003 - 0,02	0,02 - 0,04	0,03 - 0,08			4.1
80 - 140	100 - 200			0,04 - 0,07	0,05 - 0,15			1.1
80 - 140	100 - 200			0,04 - 0,07	0,05 - 0,15			1.2
60 - 120	80 - 200			0,04 - 0,07	0,05 - 0,15			2.1
60 - 120	80 - 200			0,04 - 0,07	0,05 - 0,15			2.2
60 - 120	80 - 200			0,04 - 0,07	0,05 - 0,15			3.1
60 - 120	80 - 200			0,04 - 0,07	0,05 - 0,15			3.2
60 - 120	80 - 200			0,04 - 0,07	0,05 - 0,15			4.1
60 - 120	80 - 200			0,04 - 0,07	0,05 - 0,15			4.2
100 - 250	150 - 400		0,01 - 0,05	0,05 - 0,08	0,07 - 0,20			1.1
100 - 250	150 - 400		0,01 - 0,05	0,05 - 0,08	0,07 - 0,20			1.2
100 - 250	150 - 400		0,01 - 0,05	0,05 - 0,08	0,07 - 0,20			1.3
150 - 250	150 - 400		0,01 - 0,05	0,05 - 0,08	0,07 - 0,20			1.4
150 - 250	150 - 400		0,01 - 0,05	0,05 - 0,08	0,07 - 0,20			1.5
	100 - 200		0,01 - 0,05	0,05 - 0,08	0,07 - 0,20			1.6
100 - 250	150 - 400		0,008 - 0,05	0,05 - 0,08	0,07 - 0,20			2.1
100 - 250	150 - 400		0,008 - 0,05	0,05 - 0,08	0,07 - 0,20			2.2
100 - 250	150 - 400		0,008 - 0,05	0,05 - 0,08	0,07 - 0,20			2.3
60 - 150	100 - 250		0,008 - 0,04	0,04 - 0,07	0,05 - 0,15			2.4
60 - 150	100 - 250		0,008 - 0,04	0,04 - 0,07	0,05 - 0,15			2.5
60 - 150	100 - 250		0,008 - 0,04	0,04 - 0,07	0,05 - 0,15			2.6
80 - 200	100 - 250		0,008 - 0,04	0,04 - 0,07	0,05 - 0,15			2.7
	40 - 80		0,003 - 0,02	0,02 - 0,05	0,04 - 0,15			2.7
	30 - 60		0,003 - 0,02	0,02 - 0,05	0,04 - 0,15			2.8
150 - 250	150 - 400		0,01 - 0,05	0,05 - 0,08	0,07 - 0,20			3.1
150 - 250	150 - 400		0,01 - 0,05	0,05 - 0,08	0,07 - 0,20			3.2
60 - 150	100 - 400		0,01 - 0,05	0,05 - 0,10	0,08 - 0,25			4.1
60 - 150	100 - 400		0,01 - 0,05	0,05 - 0,10	0,08 - 0,25			4.2
	80 - 120		0,01 - 0,05	0,05 - 0,10	0,08 - 0,25			4.3
	80 - 120		0,01 - 0,05	0,05 - 0,10	0,08 - 0,25			4.4
	100 - 200			0,04 - 0,07	0,08 - 0,25			5.1
	30 - 60			0,02 - 0,04	0,03 - 0,08			5.2
								5.3
15 - 50	30 - 80		0,003 - 0,03	0,03 - 0,05	0,04 - 0,10			1.1
15 - 50	30 - 80		0,003 - 0,03	0,03 - 0,05	0,04 - 0,10			1.2
15 - 40	30 - 60		0,003 - 0,02	0,02 - 0,04	0,03 - 0,08			1.3
								2.1
								2.2
								2.3
								2.4
								2.5
								2.6
								1.1
								1.2
								1.3
								1.4
								1.5

Product Finder

v_c / f_z

M

MF

UNC
UN, UNS

UNF
UNEF

G, Rp

NPT, NPTF
Rc, W

BSW, BSF

Pg

EG (STI)
SELF-LOCK

Tr

Zubehör
Accessories

Tech. Info

BGF

ZBGF

GSF

GF

GF-KEG

ZGF

ZIRK-GF

Gigant

MoSys

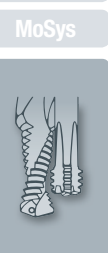

ZBGF-T



ZBGF-W



ZBGF-H



Gigant

		v_c	f_z	v_c	f_z	v_c	f_z	v_c	f_z
		Beschichtet Coated		Beschichtet Coated		Beschichtet Coated		Beschichtet Coated	
P	1.1			150 - 250	0,04 - 0,08			250 - 500	0,15 - 0,25
	2.1			150 - 250	0,04 - 0,08			250 - 500	0,15 - 0,25
	3.1			100 - 250	0,03 - 0,08			150 - 250	0,10 - 0,15
	4.1			100 - 250	0,03 - 0,08			150 - 250	0,10 - 0,15
	5.1			100 - 200	0,02 - 0,06			150 - 250	0,10 - 0,15
M	1.1			100 - 180	0,02 - 0,05			80 - 150	0,10 - 0,15
	2.1			100 - 180	0,02 - 0,05			80 - 150	0,10 - 0,15
	3.1			60 - 120	0,02 - 0,04			60 - 120	0,08 - 0,12
	4.1			60 - 120	0,02 - 0,04			60 - 120	0,08 - 0,12
K	1.1	200 - 300	0,04 - 0,12	200 - 300	0,04 - 0,10			180 - 400	0,15 - 0,25
	1.2	200 - 300	0,04 - 0,12	200 - 300	0,04 - 0,10			180 - 400	0,15 - 0,25
	2.1			150 - 250	0,05 - 0,08			180 - 400	0,15 - 0,25
	2.2			150 - 250	0,05 - 0,08			180 - 400	0,15 - 0,25
	3.1			150 - 250	0,05 - 0,08			150 - 250	0,10 - 0,15
	3.2			150 - 250	0,05 - 0,08			150 - 250	0,10 - 0,15
	4.1			200 - 300	0,05 - 0,10			180 - 400	0,15 - 0,25
	4.2			200 - 300	0,05 - 0,10			180 - 400	0,15 - 0,25
N	1.1	200 - 300	0,04 - 0,08	200 - 300	0,05 - 0,10			400 - 500	0,15 - 0,30
	1.2	200 - 300	0,04 - 0,08	200 - 300	0,05 - 0,10			400 - 500	0,15 - 0,30
	1.3	200 - 300	0,04 - 0,08	200 - 300	0,05 - 0,10			400 - 500	0,15 - 0,30
	1.4	200 - 300	0,04 - 0,08	200 - 300	0,05 - 0,10			400 - 500	0,15 - 0,30
	1.5	200 - 300	0,04 - 0,10	200 - 300	0,05 - 0,10			400 - 500	0,15 - 0,30
	1.6	100 - 200	0,04 - 0,10	100 - 200	0,05 - 0,10			150 - 250	0,15 - 0,30
	2.1			100 - 180	0,03 - 0,05			250 - 500	0,15 - 0,25
	2.2			150 - 250	0,05 - 0,08			250 - 500	0,15 - 0,25
	2.3			200 - 300	0,05 - 0,10			250 - 500	0,15 - 0,25
	2.4			100 - 180	0,03 - 0,05			150 - 250	0,10 - 0,25
	2.5			100 - 180	0,03 - 0,05			150 - 250	0,10 - 0,25
	2.6			200 - 300	0,05 - 0,10			150 - 250	0,10 - 0,25
	2.7					40 - 60	0,02 - 0,04	80 - 150	0,10 - 0,15
	2.8					40 - 60	0,02 - 0,04	80 - 150	0,10 - 0,15
	3.1	200 - 300	0,04 - 0,10	200 - 300	0,05 - 0,10			400 - 500	0,15 - 0,30
	3.2	200 - 300	0,04 - 0,10	200 - 300	0,05 - 0,10			400 - 500	0,15 - 0,30
	4.1			150 - 250	0,05 - 0,08			180 - 400	0,15 - 0,25
	4.2							180 - 400	0,15 - 0,25
	4.3			80 - 150	0,05 - 0,08			80 - 150	0,15 - 0,25
	4.4			80 - 150	0,05 - 0,08			80 - 150	0,15 - 0,25
5.1									
5.2									
5.3									
S	1.1			60 - 120	0,02 - 0,04			60 - 120	0,08 - 0,12
	1.2			60 - 120	0,02 - 0,04			60 - 120	0,08 - 0,12
	1.3			60 - 120	0,02 - 0,04			60 - 120	0,08 - 0,12
	2.1			60 - 120	0,02 - 0,04				
	2.2			60 - 120	0,02 - 0,04				
	2.3								
H	1.1			60 - 100	0,02 - 0,06	60 - 100	0,03 - 0,06		
	1.2			60 - 100	0,02 - 0,06	60 - 100	0,03 - 0,06		
	1.3					40 - 70	0,02 - 0,04		
	1.4					30 - 60	0,02 - 0,04		
	1.5					30 - 60	0,02 - 0,04		

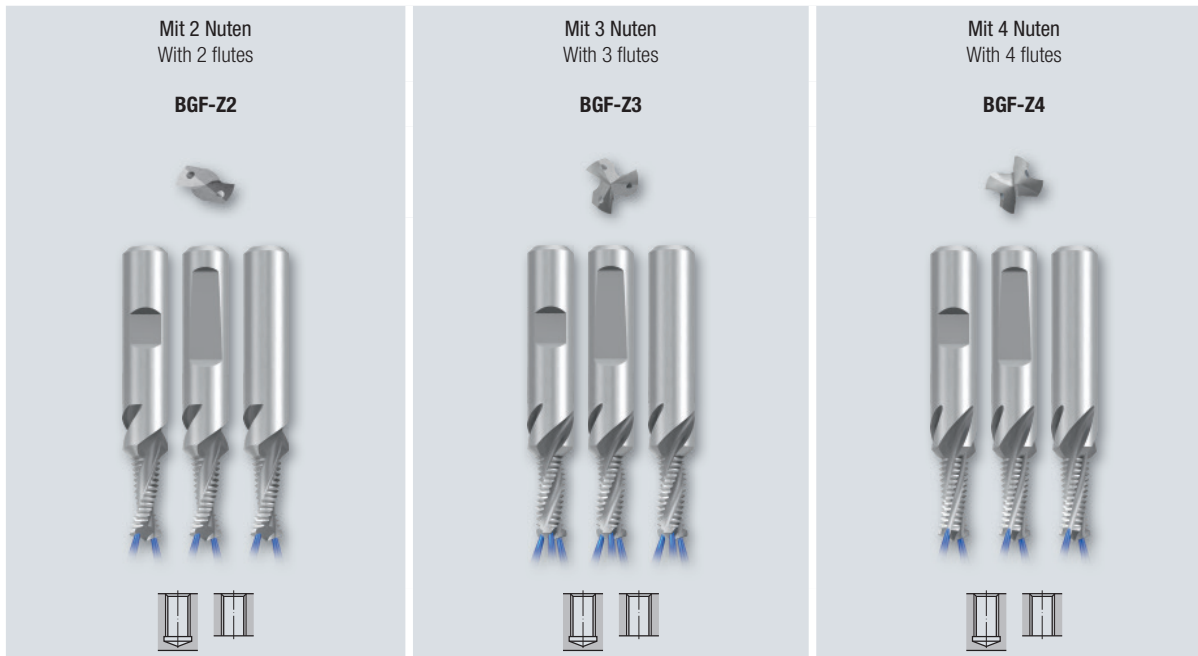

Seite · Page

334 - 335	336 - 337	338 - 339	M
340 - 341		342 - 343	MF
344 - 345			UNC
346 - 347			UNF
348 - 349			G (BSP)
350 - 351			EG M (STI)

Product Finder

- v_c / f_z
- M
- MF
- UNC
UN, UNS
- UNF
UNEF
- G, Rp
- NPT, NPTF
Rc, W
- BSW, BSF
- Pg
- EG (STI)
SELF-LOCK
- Tr

Zubehör
Accessories

Tech. Info

BGF

ZBGF

GSF

GF

GF-KEG

ZGF

ZIRK-GF

Gigant

MoSys



Mögliche Modifikationen · Possible modifications



Stirrfase am Bohrteil
Face chamfer on the drill part



AZR/AZ (ausgesetzte Zähne)
AZR/AZ (alternating teeth)



Unvollständigen Gang entfernen
Remove incomplete thread



Schaftkühlritzen
Coolant grooves along the shank

Eine Beschreibung dieser Modifikationsmöglichkeiten finden Sie auf Seite 456 - 457
For a description of these modifications, see pages 456 - 457

Gewindefräszyklus · Thread milling cycle

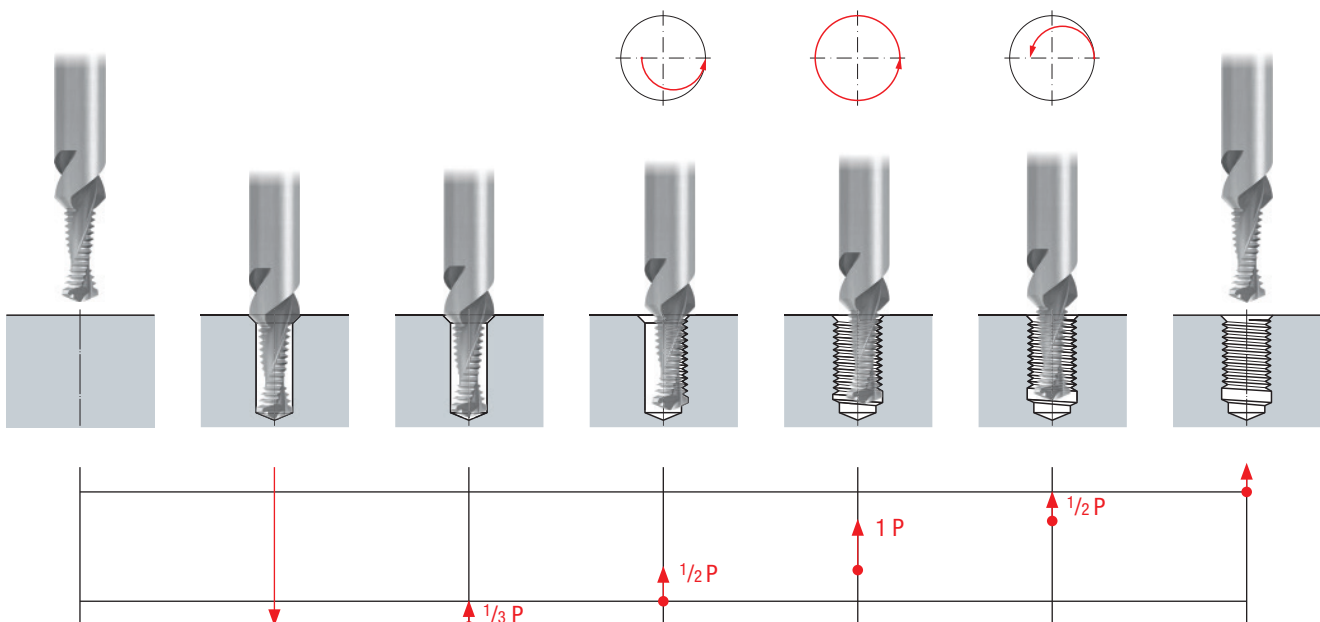

- Product Finder
- v_c / f_z
- M
- MF
- UNC UN, UNS
- UNF UNEF
- G, Rp
- NPT, NPTF Rc, W
- BSW, BSF
- Pg
- EG (STI) SELF-LOCK
- Tr
- Zubehör Accessories
- Tech. Info
- BGF
- ZBGF
- GSF
- GF
- GF-KEG
- ZGF
- ZIRK-GF
- Gigant
- MoSys

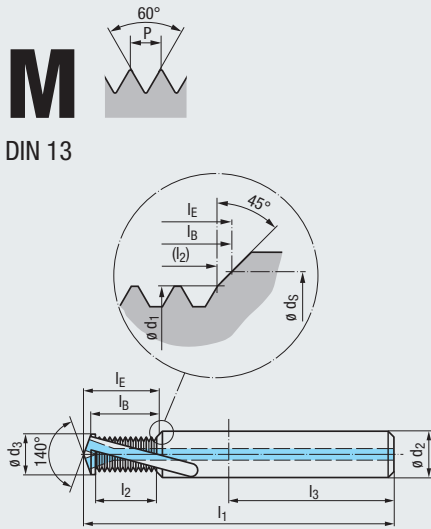

VHM

R30 **RH + LH**

Z2 **DIN 6535**
 HB
 HE
 HA

90° **∅ D**

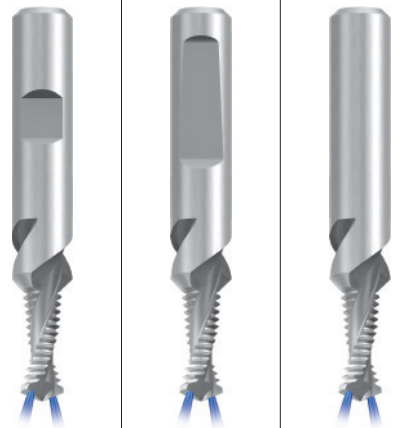

Einsatzgebiete – Material Applications – material **328**

K 1.1-3.2 **N 1.1-5**
N 2.2-3, 2.6 **N 3.1-2, 4.1**

Gewindetiefe Thread depth

1,5 x D

Werkzeug-Ident · Tool ident

	GF422201	GF422501	GF422801
BGF-VHM-Z2 1,5xD R30-IKZ-HB	●	●	●
BGF-VHM-Z2 1,5xD R30-IKZ-HE	●	●	●
BGF-VHM-Z2 1,5xD R30-IKZ-HA	●	●	●

∅ D mm	P mm	l ₁	l ₂	l ₃	∅ d ₁	∅ d ₂	∅ d ₃	∅ d _S	l _B	l _E	Dimens.-Ident
4	0,7	49	5,64	36	3,16	6	3,3	4,3	6,8	7,4	.0040
5	0,8	55	7,25	36	4,04	6	4,2	5,3	8,6	9,4	.0050
6	1	62	9,06	36	4,8	8	5	6,3	10,7	11,6	.0060
8	1,25	74	11,33	40	6,5	10	6,75	8,3	13,4	14,6	.0080
10	1,5	79	15,09	45	8,2	12	8,5	10,3	17,5	19,1	.0100
12	1,75	89	17,61	45	9,9	14	10,25	12,3	20,4	22,3	.0112
14	2	102	20,12	48	11,6	16	12	14,3	23,3	25,5	.0114
16	2	102	24,13	48	13,6	18	14	16,3	27,3	29,9	.0116

Gewindetiefe Thread depth

2 x D

Werkzeug-Ident · Tool ident

	GF432201	GF432501	GF432801
BGF-VHM-Z2 2xD R30-IKZ-HB	●	●	●
BGF-VHM-Z2 2xD R30-IKZ-HE	●	●	●
BGF-VHM-Z2 2xD R30-IKZ-HA	●	●	●

∅ D mm	P mm	l ₁	l ₂	l ₃	∅ d ₁	∅ d ₂	∅ d ₃	∅ d _S	l _B	l _E	Dimens.-Ident
4	0,7	49	7,74	36	3,16	6	3,3	4,3	8,9	9,5	.0040
5	0,8	55	9,65	36	4,04	6	4,2	5,3	11	11,8	.0050
6	1	62	12,06	36	4,8	8	5	6,3	13,7	14,6	.0060
8	1,25	74	15,08	40	6,5	10	6,75	8,3	17,1	18,3	.0080
10	1,5	79	19,59	45	8,2	12	8,5	10,3	22	23,6	.0100
12	1,75	89	22,86	45	9,9	14	10,25	12,3	25,7	27,5	.0112
14	2	102	28,12	48	11,6	16	12	14,3	31,3	33,5	.0114
16	2	102	32,13	48	13,6	18	14	16,3	35,3	37,9	.0116

Gewindetiefe Thread depth

2,5 x D

Werkzeug-Ident · Tool ident

	GF442201	GF442501	GF442801
BGF-VHM-Z2 2,5xD R30-IKZ-HB	●	●	●
BGF-VHM-Z2 2,5xD R30-IKZ-HE	●	●	●
BGF-VHM-Z2 2,5xD R30-IKZ-HA	●	●	●

∅ D mm	P mm	l ₁	l ₂	l ₃	∅ d ₁	∅ d ₂	∅ d ₃	∅ d _S	l _B	l _E	Dimens.-Ident
6	1	65	15,10	36	4,8	8	5	6,3	16,7	17,6	.0060
8	1,25	80	20,08	40	6,5	10	6,75	8,3	22,1	23,3	.0080
10	1,5	85	25,59	45	8,2	12	8,5	10,3	28	29,6	.0100
12	1,75	95	29,86	45	9,9	14	10,25	12,3	32,7	34,5	.0112
14	2	110	36,12	48	11,6	16	12	14,3	39,3	41,5	.0114
16	2	110	40,13	48	13,6	18	14	16,3	43,3	45,9	.0116

Andere Abmessungen auf Anfrage
 Other sizes upon request

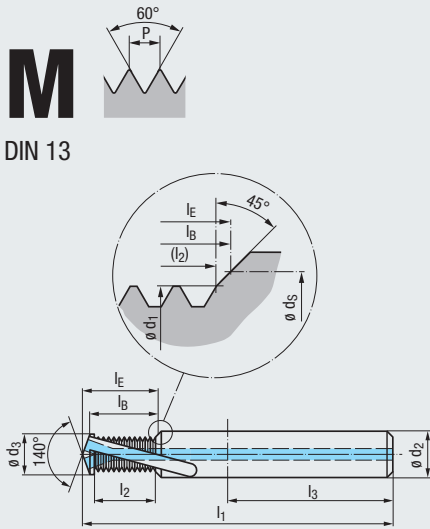

M

DIN 13

VHM	TICN
R30	RH + LH
Z2	DIN 6535 HB HE HA
90°	ø D

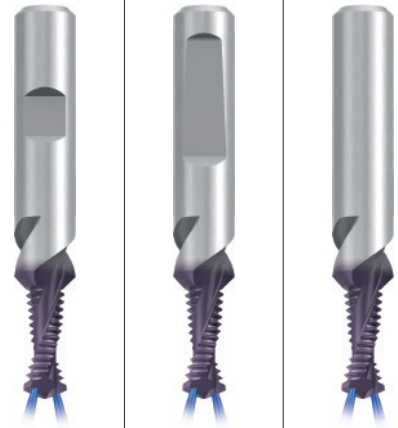

- Product Finder
- v_c / f_z
- M
- MF
- UNC UN, UNS
- UNF UNEF
- G, Rp
- NPT, NPTF Rc, W
- BSW, BSF
- Pg
- EG (STI) SELF-LOCK

Einsatzgebiete – Material Applications – material ▶ 328

K 1.1-3.2 N 1.1-6
N 2.2-3, 2.6 N 3.1-2, 4.1

Gewindetiefe Thread depth

1,5 x D

Werkzeug-Ident · Tool ident

ø D mm	P mm	l ₁	l ₂	l ₃	ø d ₁	ø d ₂	ø d ₃	ø d _S	l _B	l _E	Dimens.-Ident	GF422206	GF422506	GF422806
												BGF-VHM-Z2 1,5xD R30-1KZ-HB TICN	BGF-VHM-Z2 1,5xD R30-1KZ-HE TICN	BGF-VHM-Z2 1,5xD R30-1KZ-HA TICN
M 4	0,7	49	5,64	36	3,16	6	3,3	4,3	6,8	7,4	.0040	●	●	●
5	0,8	55	7,25	36	4,04	6	4,2	5,3	8,6	9,4	.0050	●	●	●
6	1	62	9,06	36	4,8	8	5	6,3	10,7	11,6	.0060	●	●	●
8	1,25	74	11,33	40	6,5	10	6,75	8,3	13,4	14,6	.0080	●	●	●
10	1,5	79	15,09	45	8,2	12	8,5	10,3	17,5	19,1	.0100	●	●	●
12	1,75	89	17,61	45	9,9	14	10,25	12,3	20,4	22,3	.0112	●	●	●
14	2	102	20,12	48	11,6	16	12	14,3	23,3	25,5	.0114	●	●	●
16	2	102	24,13	48	13,6	18	14	16,3	27,3	29,9	.0116	●	●	●

Gewindetiefe Thread depth

2 x D

Werkzeug-Ident · Tool ident

ø D mm	P mm	l ₁	l ₂	l ₃	ø d ₁	ø d ₂	ø d ₃	ø d _S	l _B	l _E	Dimens.-Ident	GF432206	GF432506	GF432806
												BGF-VHM-Z2 2xD R30-1KZ-HB TICN	BGF-VHM-Z2 2xD R30-1KZ-HE TICN	BGF-VHM-Z2 2xD R30-1KZ-HA TICN
M 4	0,7	49	7,74	36	3,16	6	3,3	4,3	8,9	9,5	.0040	●	●	●
5	0,8	55	9,65	36	4,04	6	4,2	5,3	11	11,8	.0050	●	●	●
6	1	62	12,06	36	4,8	8	5	6,3	13,7	14,6	.0060	●	●	●
8	1,25	74	15,08	40	6,5	10	6,75	8,3	17,1	18,3	.0080	●	●	●
10	1,5	79	19,59	45	8,2	12	8,5	10,3	22	23,6	.0100	●	●	●
12	1,75	89	22,86	45	9,9	14	10,25	12,3	25,7	27,5	.0112	●	●	●
14	2	102	28,12	48	11,6	16	12	14,3	31,3	33,5	.0114	●	●	●
16	2	102	32,13	48	13,6	18	14	16,3	35,3	37,9	.0116	●	●	●

Gewindetiefe Thread depth

2,5 x D

Werkzeug-Ident · Tool ident

ø D mm	P mm	l ₁	l ₂	l ₃	ø d ₁	ø d ₂	ø d ₃	ø d _S	l _B	l _E	Dimens.-Ident	GF442206	GF442506	GF442806
												BGF-VHM-Z2 2,5xD R30-1KZ-HB TICN	BGF-VHM-Z2 2,5xD R30-1KZ-HE TICN	BGF-VHM-Z2 2,5xD R30-1KZ-HA TICN
M 6	1	65	15,10	36	4,8	8	5	6,3	16,7	17,6	.0060	●	●	●
8	1,25	80	20,08	40	6,5	10	6,75	8,3	22,1	23,3	.0080	●	●	●
10	1,5	85	25,59	45	8,2	12	8,5	10,3	28	29,6	.0100	●	●	●
12	1,75	95	29,86	45	9,9	14	10,25	12,3	32,7	34,5	.0112	●	●	●
14	2	110	36,12	48	11,6	16	12	14,3	39,3	41,5	.0114	●	●	●
16	2	110	40,13	48	13,6	18	14	16,3	43,3	45,9	.0116	●	●	●

Andere Abmessungen auf Anfrage Other sizes upon request

Product Finder

v_c / f_z

M

MF

UNC
UN, UNS

UNF
UNEF

G, Rp

NPT, NPTF
Rc, W

BSW, BSF

Pg

EG (STI)
SELF-LOCK

Tr

Zubehör
Accessories

Tech. Info

BGF

ZBGF

GSF

GF

GF-KEG

ZGF

ZIRK-GF

Gigant

MoSys

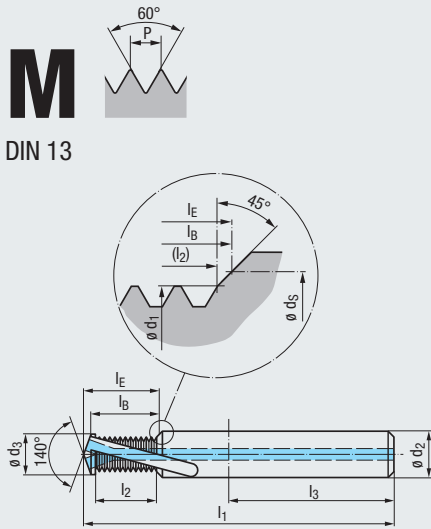
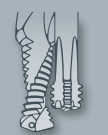

VHM

R30

RH + LH

Z3

DIN 6535

HB
HE
HA

90°

$\varnothing D$

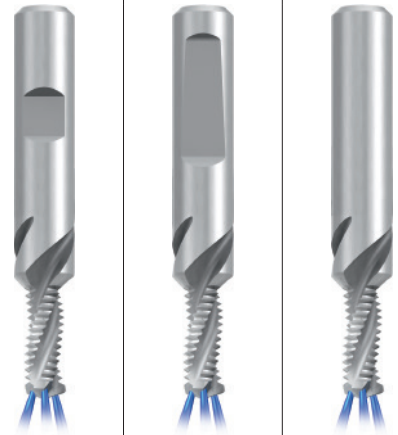

K 1.1-2 N 1.5, 2,3

Einsatzgebiete – Material
Applications – material



Gewindetiefe
Thread depth

1,5 x D

Werkzeug-Ident · Tool ident

GF422251 GF422551 GF422851

$\varnothing D$ mm	P mm	l_1	l_2	l_3	$\varnothing d_1$	$\varnothing d_2$	$\varnothing d_3$	$\varnothing d_S$	l_B	l_E	Dimens.- Ident	BGF-VHM-Z3 1,5xD R30-IKZ-HB	BGF-VHM-Z3 1,5xD R30-IKZ-HE	BGF-VHM-Z3 1,5xD R30-IKZ-HA
M 6	1	62	9,06	36	4,8	8	5	6,3	10,7	11,6	.0060	●	●	●
8	1,25	74	11,33	40	6,5	10	6,75	8,3	13,4	14,6	.0080	●	●	●
10	1,5	79	15,09	45	8,2	12	8,5	10,3	17,5	19,1	.0100	●	●	●
12	1,75	89	17,61	45	9,9	14	10,25	12,3	20,4	22,3	.0112	●	●	●
16	2	102	24,13	48	13,6	18	14	16,3	27,3	29,9	.0116	●	●	●

Gewindetiefe
Thread depth

2 x D

Werkzeug-Ident · Tool ident

GF432251 GF432551 GF432851

$\varnothing D$ mm	P mm	l_1	l_2	l_3	$\varnothing d_1$	$\varnothing d_2$	$\varnothing d_3$	$\varnothing d_S$	l_B	l_E	Dimens.- Ident	BGF-VHM-Z3 2xD R30-IKZ-HB	BGF-VHM-Z3 2xD R30-IKZ-HE	BGF-VHM-Z3 2xD R30-IKZ-HA
M 6	1	62	12,06	36	4,8	8	5	6,3	13,7	14,6	.0060	●	●	●
8	1,25	74	15,08	40	6,5	10	6,75	8,3	17,1	18,3	.0080	●	●	●
10	1,5	79	19,59	45	8,2	12	8,5	10,3	22	23,6	.0100	●	●	●
12	1,75	89	22,86	45	9,9	14	10,25	12,3	25,7	27,5	.0112	●	●	●
16	2	102	32,13	48	13,6	18	14	16,3	35,3	37,9	.0116	●	●	●

Gewindetiefe
Thread depth

2,5 x D

Werkzeug-Ident · Tool ident

GF442251 GF442551 GF442851

$\varnothing D$ mm	P mm	l_1	l_2	l_3	$\varnothing d_1$	$\varnothing d_2$	$\varnothing d_3$	$\varnothing d_S$	l_B	l_E	Dimens.- Ident	BGF-VHM-Z3 2,5xD R30-IKZ-HB	BGF-VHM-Z3 2,5xD R30-IKZ-HE	BGF-VHM-Z3 2,5xD R30-IKZ-HA
M 6	1	65	15,10	36	4,8	8	5	6,3	16,7	17,6	.0060	●	●	●
8	1,25	80	20,08	40	6,5	10	6,75	8,3	22,1	23,3	.0080	●	●	●
10	1,5	85	25,59	45	8,2	12	8,5	10,3	28	29,6	.0100	●	●	●
12	1,75	95	29,86	45	9,9	14	10,25	12,3	32,7	34,5	.0112	●	●	●
16	2	110	40,13	48	13,6	18	14	16,3	43,3	45,9	.0116	●	●	●

Andere Abmessungen auf Anfrage
Other sizes upon request

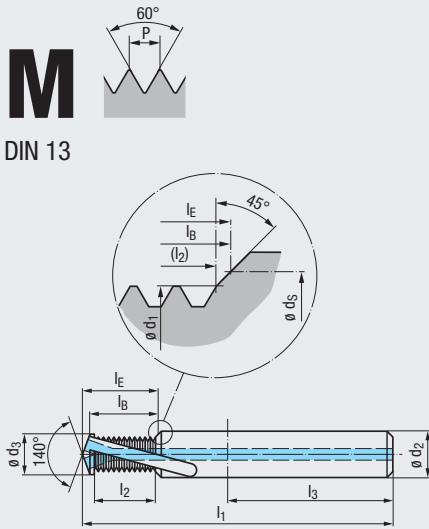

VHM	TICN
R30	RH + LH
Z3	DIN 6535 HB HE HA
90°	ø D

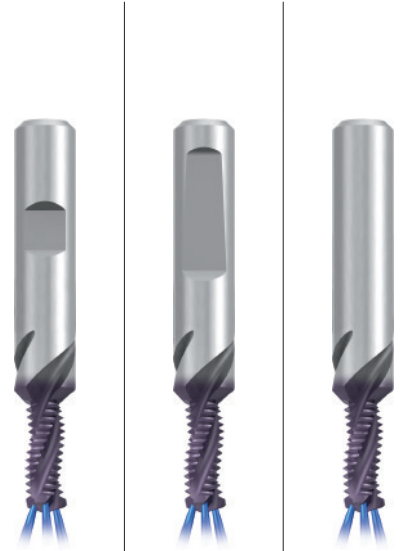

- Product Finder
- v_c / f_z
- M
- MF
- UNC
UN, UNS
- UNF
UNEF
- G, Rp
- NPT, NPTF
Rc, W
- BSW, BSF
- Pg
- EG (STI)
SELF-LOCK
- Tr
- Zubehör
Accessories
- Tech. Info
- BGF
- ZBGF
- GSF
- GF
- GF-KEG
- ZGF
- ZIRK-GF
- Gigant
- MoSys

Einsatzgebiete – Material Applications – material ▶▶ 328

K 1.1-2 **N** 1.5-6, 2.3

Gewindetiefe Thread depth

1,5 x D

Werkzeug-Ident · Tool ident

ø D mm	P mm	l ₁	l ₂	l ₃	ø d ₁	ø d ₂	ø d ₃	ø d _S	l _B	l _E	Dimens.- Ident	GF42256	GF42256	GF422856
												BGF-VHM-Z3 1,5xD R30-IKZ-HB TICN	BGF-VHM-Z3 1,5xD R30-IKZ-HE TICN	BGF-VHM-Z3 1,5xD R30-IKZ-HA TICN
M 6	1	62	9,06	36	4,8	8	5	6,3	10,7	11,6	.0060	●	●	●
8	1,25	74	11,33	40	6,5	10	6,75	8,3	13,4	14,6	.0080	●	●	●
10	1,5	79	15,09	45	8,2	12	8,5	10,3	17,5	19,1	.0100	●	●	●
12	1,75	89	17,61	45	9,9	14	10,25	12,3	20,4	22,3	.0112	●	●	●
16	2	102	24,13	48	13,6	18	14	16,3	27,3	29,9	.0116	●	●	●

Gewindetiefe Thread depth

2 x D

Werkzeug-Ident · Tool ident

ø D mm	P mm	l ₁	l ₂	l ₃	ø d ₁	ø d ₂	ø d ₃	ø d _S	l _B	l _E	Dimens.- Ident	GF432256	GF43256	GF432856
												BGF-VHM-Z3 2xD R30-IKZ-HB TICN	BGF-VHM-Z3 2xD R30-IKZ-HE TICN	BGF-VHM-Z3 2xD R30-IKZ-HA TICN
M 6	1	62	12,06	36	4,8	8	5	6,3	13,7	14,6	.0060	●	●	●
8	1,25	74	15,08	40	6,5	10	6,75	8,3	17,1	18,3	.0080	●	●	●
10	1,5	79	19,59	45	8,2	12	8,5	10,3	22	23,6	.0100	●	●	●
12	1,75	89	22,86	45	9,9	14	10,25	12,3	25,7	27,5	.0112	●	●	●
16	2	102	32,13	48	13,6	18	14	16,3	35,3	37,9	.0116	●	●	●

Gewindetiefe Thread depth

2,5 x D

Werkzeug-Ident · Tool ident

ø D mm	P mm	l ₁	l ₂	l ₃	ø d ₁	ø d ₂	ø d ₃	ø d _S	l _B	l _E	Dimens.- Ident	GF442256	GF44256	GF442856
												BGF-VHM-Z3 2,5xD R30-IKZ-HB TICN	BGF-VHM-Z3 2,5xD R30-IKZ-HE TICN	BGF-VHM-Z3 2,5xD R30-IKZ-HA TICN
M 6	1	65	15,10	36	4,8	8	5	6,3	16,7	17,6	.0060	●	●	●
8	1,25	80	20,08	40	6,5	10	6,75	8,3	22,1	23,3	.0080	●	●	●
10	1,5	85	25,59	45	8,2	12	8,5	10,3	28	29,6	.0100	●	●	●
12	1,75	95	29,86	45	9,9	14	10,25	12,3	32,7	34,5	.0112	●	●	●
16	2	110	40,13	48	13,6	18	14	16,3	43,3	45,9	.0116	●	●	●

Andere Abmessungen auf Anfrage
Other sizes upon request

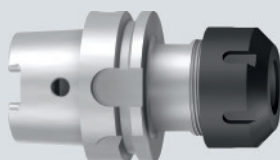

Spannzangen-Aufnahmen
Typ KSN/Synchro
siehe Seite 711 - 713

Collet holders
type KSN/Synchro,
see page 711 - 713

- Product Finder
- v_c / f_z
- M
- MF
- UNC UN, UNS
- UNF UNEF
- G, Rp
- NPT, NPTF Rc, W
- BSW, BSF
- Pg
- EG (STI) SELF-LOCK
- Tr
- Zubehör Accessories
- Tech. Info
- BGF
- ZBGF
- GSF
- GF
- GF-KEG
- ZGF
- ZIRK-GF
- Gigant
- MoSys

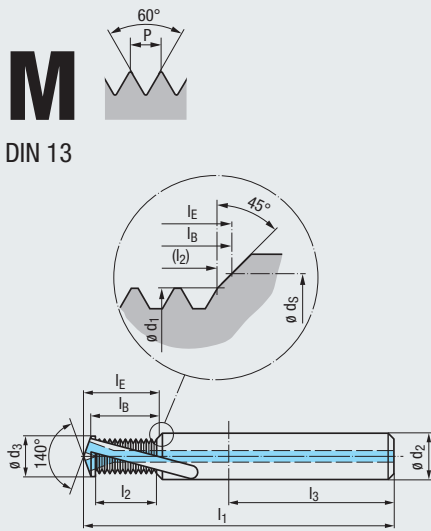

VHM	TICN
R20	RH + LH
Z4	DIN 6535 HB HE HA
90°	$\varnothing D$

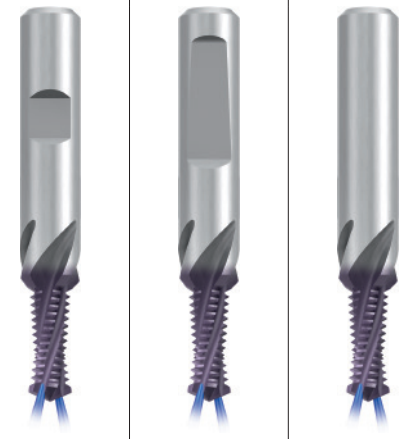

Einsatzgebiete – Material Applications – material » 328

K 1.1-2 **N** 1.5-6, 2.3

Gewindetiefe Thread depth												1,5 x D		
Werkzeug-Ident · Tool ident												GF429246	GF429546	GF429846
$\varnothing D$ mm	P mm	l_1	l_2	l_3	$\varnothing d_1$	$\varnothing d_2$	$\varnothing d_3$	$\varnothing d_S$	l_B	l_E	Dimens.-Ident	BGF-VHM-Z4 1,5xD R20- IKZ-HB TICN	BGF-VHM-Z4 1,5xD R20- IKZ-HE TICN	BGF-VHM-Z4 1,5xD R20- IKZ-HA TICN
M 6	1	62	9,06	36	4,8	8	5	6,3	10,7	11,6	.0060	●	●	●
8	1,25	74	11,33	40	6,5	10	6,75	8,3	13,4	14,6	.0080	●	●	●
10	1,5	79	15,09	45	8,2	12	8,5	10,3	17,5	19,1	.0100	●	●	●
12	1,75	89	17,61	45	9,9	14	10,25	12,3	20,4	22,3	.0112	●	●	●

Gewindetiefe Thread depth												2 x D		
Werkzeug-Ident · Tool ident												GF439246	GF439546	GF439846
$\varnothing D$ mm	P mm	l_1	l_2	l_3	$\varnothing d_1$	$\varnothing d_2$	$\varnothing d_3$	$\varnothing d_S$	l_B	l_E	Dimens.-Ident	BGF-VHM-Z4 2xD R20- IKZ-HB TICN	BGF-VHM-Z4 2xD R20- IKZ-HE TICN	BGF-VHM-Z4 2xD R20- IKZ-HA TICN
M 6	1	62	12,06	36	4,8	8	5	6,3	13,7	14,6	.0060	●	●	●
8	1,25	74	15,08	40	6,5	10	6,75	8,3	17,1	18,3	.0080	●	●	●
10	1,5	79	19,59	45	8,2	12	8,5	10,3	22	23,6	.0100	●	●	●
12	1,75	89	22,86	45	9,9	14	10,25	12,3	25,7	27,5	.0112	●	●	●
16	2	102	32,13	48	13,6	18	14	16,3	35,3	37,9	.0116	●	●	●

Gewindetiefe Thread depth												2,5 x D		
Werkzeug-Ident · Tool ident												GF449246	GF449546	GF449846
$\varnothing D$ mm	P mm	l_1	l_2	l_3	$\varnothing d_1$	$\varnothing d_2$	$\varnothing d_3$	$\varnothing d_S$	l_B	l_E	Dimens.-Ident	BGF-VHM-Z4 2,5xD R20- IKZ-HB TICN	BGF-VHM-Z4 2,5xD R20- IKZ-HE TICN	BGF-VHM-Z4 2,5xD R20- IKZ-HA TICN
M 6	1	65	15,10	36	4,8	8	5	6,3	16,7	17,6	.0060	●	●	●
8	1,25	80	20,08	40	6,5	10	6,75	8,3	22,1	23,3	.0080	●	●	●
10	1,5	85	25,59	45	8,2	12	8,5	10,3	28	29,6	.0100	●	●	●
12	1,75	95	29,86	45	9,9	14	10,25	12,3	32,7	34,5	.0112	●	●	●
16	2	110	40,13	48	13,6	18	14	16,3	43,3	45,9	.0116	●	●	●

Andere Abmessungen auf Anfrage
Other sizes upon request

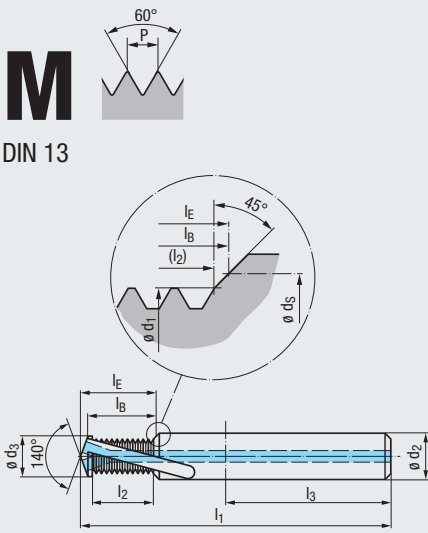

VHM	TIALN T3
R20	RH + LH
Z4	DIN 6535 HB HE HA
90°	Ø D

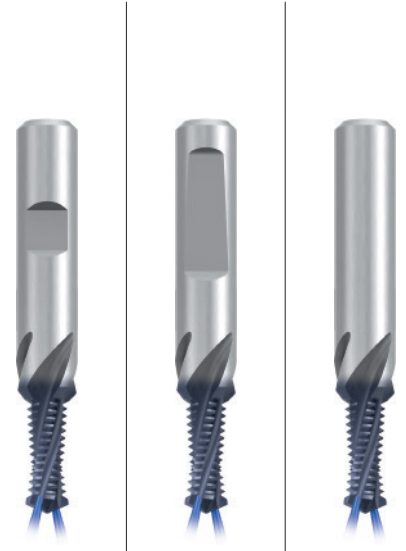

- Product Finder
- v_c / f_z
- M
- MF
- UNC UN, UNS
- UNF UNEF
- G, Rp
- NPT, NPTF Rc, W
- BSW, BSF
- Pg
- EG (STI) SELF-LOCK
- Tr
- Zubehör Accessories
- Tech. Info
- BGF
- ZBGF
- GSF
- GF
- GF-KEG
- ZGF
- ZIRK-GF
- Gigant
- MoSys

Einsatzgebiete – Material Applications – material **328**

K 1.1-2 N 1.5-6, 2.3

Gewindetiefe Thread depth

1,5 x D

Werkzeug-Ident · Tool ident

Ø D mm	P mm	l ₁	l ₂	l ₃	Ø d ₁	Ø d ₂	Ø d ₃	Ø d _S	l _B	l _E	Dimens.-Ident	GF429248	GF429548	GF429848
												BGF-VHM-Z4 1,5xD R20-1KZ-HB TIALN-T3	BGF-VHM-Z4 1,5xD R20-1KZ-HE TIALN-T3	BGF-VHM-Z4 1,5xD R20-1KZ-HA TIALN-T3
M 6	1	62	9,06	36	4,8	8	5	6,3	10,7	11,6	.0060	●	●	●
8	1,25	74	11,33	40	6,5	10	6,75	8,3	13,4	14,6	.0080	●	●	●
10	1,5	79	15,09	45	8,2	12	8,5	10,3	17,5	19,1	.0100	●	●	●
12	1,75	89	17,61	45	9,9	14	10,25	12,3	20,4	22,3	.0112	●	●	●

Gewindetiefe Thread depth

2 x D

Werkzeug-Ident · Tool ident

Ø D mm	P mm	l ₁	l ₂	l ₃	Ø d ₁	Ø d ₂	Ø d ₃	Ø d _S	l _B	l _E	Dimens.-Ident	GF439248	GF439548	GF439848
												BGF-VHM-Z4 2xD R20-1KZ-HB TIALN-T3	BGF-VHM-Z4 2xD R20-1KZ-HE TIALN-T3	BGF-VHM-Z4 2xD R20-1KZ-HA TIALN-T3
M 6	1	62	12,06	36	4,8	8	5	6,3	13,7	14,6	.0060	●	●	●
8	1,25	74	15,08	40	6,5	10	6,75	8,3	17,1	18,3	.0080	●	●	●
10	1,5	79	19,59	45	8,2	12	8,5	10,3	22	23,6	.0100	●	●	●
12	1,75	89	22,86	45	9,9	14	10,25	12,3	25,7	27,5	.0112	●	●	●
16	2	102	32,13	48	13,6	18	14	16,3	35,3	37,9	.0116	●	●	●

Gewindetiefe Thread depth

2,5 x D

Werkzeug-Ident · Tool ident

Ø D mm	P mm	l ₁	l ₂	l ₃	Ø d ₁	Ø d ₂	Ø d ₃	Ø d _S	l _B	l _E	Dimens.-Ident	GF449248	GF449548	GF449848
												BGF-VHM-Z4 2,5xD R20-1KZ-HB TIALN-T3	BGF-VHM-Z4 2,5xD R20-1KZ-HE TIALN-T3	BGF-VHM-Z4 2,5xD R20-1KZ-HA TIALN-T3
M 6	1	65	15,10	36	4,8	8	5	6,3	16,7	17,6	.0060	●	●	●
8	1,25	80	20,08	40	6,5	10	6,75	8,3	22,1	23,3	.0080	●	●	●
10	1,5	85	25,59	45	8,2	12	8,5	10,3	28	29,6	.0100	●	●	●
12	1,75	95	29,86	45	9,9	14	10,25	12,3	32,7	34,5	.0112	●	●	●
16	2	110	40,13	48	13,6	18	14	16,3	43,3	45,9	.0116	●	●	●

Andere Abmessungen auf Anfrage Other sizes upon request

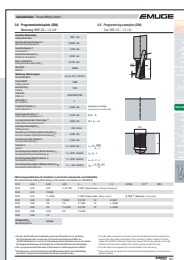

Programmierbeispiel für Bohrwinddefräser Typ BGF siehe Seite 463

Programming example for drill thread mills type BGF, see page 463

- Product Finder
- v_c / f_z
- M
- MF**
- UNC
UN, UNS
- UNF
UNEF
- G, Rp
- NPT, NPTF
Rc, W
- BSW, BSF
- Pg
- EG (STI)
SELF-LOCK
- Tr
- Zubehör
Accessories
- Tech. Info
- BGF
- ZBGF
- GSF
- GF
- GF-KEG
- ZGF
- ZIRK-GF
- Gigant
- MoSys

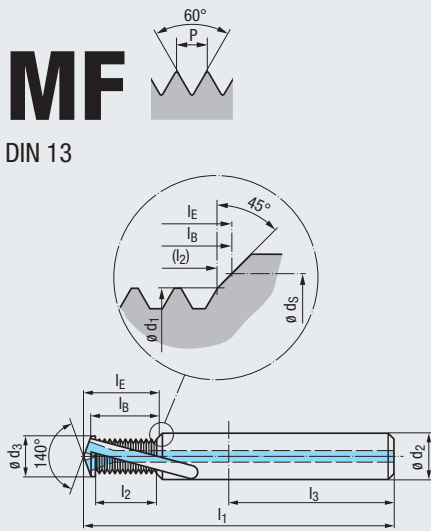

VHM

R30 **RH + LH**

Z2 **DIN 6535**
HB
HE
HA

90° **Ø D**

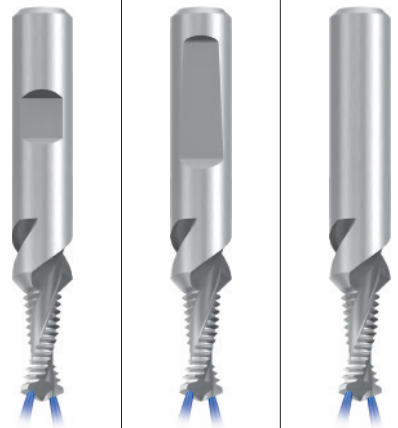

Einsatzgebiete – Material Applications – material **328**

K 1.1-3.2 **N 1.1-5**
N 2.2-3, 2.6 **N 3.1-2, 4.1**

Gewindetiefe Thread depth

1,5 x D

Werkzeug-Ident · Tool ident

	GF422201	GF422501	GF422801
BGF-VHM-Z2 1,5xD R30-IKZ-HB		BGF-VHM-Z2 1,5xD R30-IKZ-HE	BGF-VHM-Z2 1,5xD R30-IKZ-HA
•	•	•	•
•	•	•	•
•	•	•	•
•	•	•	•
•	•	•	•
•	•	•	•
•	•	•	•
•	•	•	•
•	•	•	•

Ø D mm	P mm	l ₁	l ₂	l ₃	Ø d ₁	Ø d ₂	Ø d ₃	Ø d _S	l _B	l _E	Dimens.- Ident
M 4 x 0,5	49	5,05	36	3,36	6	3,5	4,3	7	7,6	.0210	
5 x 0,5	55	7,56	36	4,34	6	4,5	5,3	8,5	9,3	.0218	
6 x 0,75	62	9,07	36	5,05	8	5,25	6,3	10,4	11,3	.0229	
8 x 1	74	12,09	40	6,75	10	7	8,3	13,8	15	.0251	
10 x 1	79	15,11	45	8,7	12	9	10,3	16,8	18,4	.0276	
10 x 1,25	79	15,11	45	8,4	12	8,75	10,3	17,2	18,8	.0277	
12 x 1	89	17,14	45	10,65	14	11	12,3	18,8	20,8	.0301	
12 x 1,25	89	18,88	45	10,4	14	10,75	12,3	20,9	22,9	.0302	
12 x 1,5	89	18,12	45	10,15	14	10,5	12,3	20,5	22,5	.0303	
14 x 1,5	102	21,14	48	12,1	16	12,5	14,3	23,6	25,8	.0331	
16 x 1,5	102	24,15	48	14,1	18	14,5	16,3	26,6	29,2	.0359	

Gewindetiefe Thread depth

2 x D

Werkzeug-Ident · Tool ident

	GF432201	GF432501	GF432801
BGF-VHM-Z2 2xD R30-IKZ-HB		BGF-VHM-Z2 2xD R30-IKZ-HE	BGF-VHM-Z2 2xD R30-IKZ-HA
•	•	•	•
•	•	•	•
•	•	•	•
•	•	•	•
•	•	•	•
•	•	•	•
•	•	•	•
•	•	•	•
•	•	•	•

Ø D mm	P mm	l ₁	l ₂	l ₃	Ø d ₁	Ø d ₂	Ø d ₃	Ø d _S	l _B	l _E	Dimens.- Ident
M 4 x 0,5	49	8,05	36	3,36	6	3,5	4,3	9	9,6	.0210	
5 x 0,5	55	10,06	36	4,34	6	4,5	5,3	11	11,8	.0218	
6 x 0,75	62	12,07	36	5,05	8	5,25	6,3	13,4	14,3	.0229	
8 x 1	74	16,09	40	6,75	10	7	8,3	17,8	19	.0251	
10 x 1	79	20,11	45	8,7	12	9	10,3	21,8	23,4	.0276	
10 x 1,25	79	20,11	45	8,4	12	8,75	10,3	22,2	23,8	.0277	
12 x 1	89	24,14	45	10,65	14	11	12,3	25,8	27,8	.0301	
12 x 1,25	89	23,88	45	10,4	14	10,75	12,3	25,9	27,9	.0302	
12 x 1,5	89	24,12	45	10,15	14	10,5	12,3	26,5	28,5	.0303	
14 x 1,5	102	27,14	48	12,1	16	12,5	14,3	29,6	31,8	.0331	
16 x 1,5	102	31,65	48	14,1	18	14,5	16,3	34,1	36,7	.0359	

Andere Abmessungen auf Anfrage Other sizes upon request

MF

DIN 13

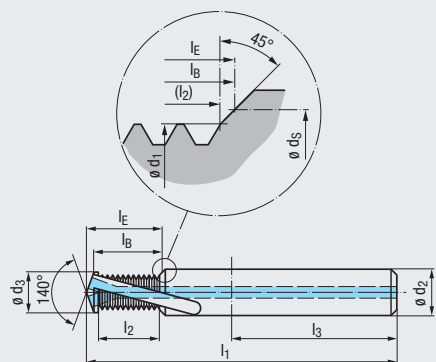

VHM **TICN**

R30 **RH + LH**

Z2 **DIN 6535**
 HB
 HE
 HA

90° **Ø D**

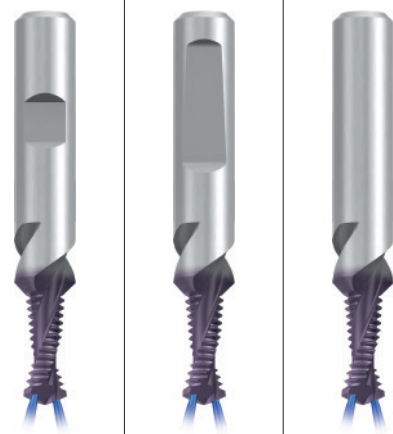

Einsatzgebiete – Material Applications – material 328

K 1.1-3.2 **N 1.1-6**
N 2.2-3, 2.6 **N 3.1-2, 4.1**

Gewindetiefe Thread depth

1,5 x D

Werkzeug-Ident · Tool ident												GF422206			GF422506			GF422806		
												BGF-VHM-Z2 1,5xD R30-IKZ-HB TICN			BGF-VHM-Z2 1,5xD R30-IKZ-HE TICN			BGF-VHM-Z2 1,5xD R30-IKZ-HA TICN		
Ø D mm	P mm	l ₁	l ₂	l ₃	Ø d ₁	Ø d ₂	Ø d ₃	Ø d _S	l _B	l _E	Dimens.-Ident									
M 4 x 0,5	49	5,05	36	3,36	6	3,5	4,3	7	7,6	.0210										
5 x 0,5	55	7,56	36	4,34	6	4,5	5,3	8,5	9,3	.0218										
6 x 0,75	62	9,07	36	5,05	8	5,25	6,3	10,4	11,3	.0229										
8 x 1	74	12,09	40	6,75	10	7	8,3	13,8	15	.0251										
10 x 1	79	15,11	45	8,7	12	9	10,3	16,8	18,4	.0276										
10 x 1,25	79	15,11	45	8,4	12	8,75	10,3	17,2	18,8	.0277										
12 x 1	89	17,14	45	10,65	14	11	12,3	18,8	20,8	.0301										
12 x 1,25	89	18,88	45	10,4	14	10,75	12,3	20,9	22,9	.0302										
12 x 1,5	89	18,12	45	10,15	14	10,5	12,3	20,5	22,5	.0303										
14 x 1,5	102	21,14	48	12,1	16	12,5	14,3	23,6	25,8	.0331										
16 x 1,5	102	24,15	48	14,1	18	14,5	16,3	26,6	29,2	.0359										

Gewindetiefe Thread depth

2 x D

Werkzeug-Ident · Tool ident												GF432206			GF432506			GF432806		
												BGF-VHM-Z2 2xD R30-IKZ-HB TICN			BGF-VHM-Z2 2xD R30-IKZ-HE TICN			BGF-VHM-Z2 2xD R30-IKZ-HA TICN		
Ø D mm	P mm	l ₁	l ₂	l ₃	Ø d ₁	Ø d ₂	Ø d ₃	Ø d _S	l _B	l _E	Dimens.-Ident									
M 4 x 0,5	49	8,05	36	3,36	6	3,5	4,3	9	9,6	.0210										
5 x 0,5	55	10,06	36	4,34	6	4,5	5,3	11	11,8	.0218										
6 x 0,75	62	12,07	36	5,05	8	5,25	6,3	13,4	14,3	.0229										
8 x 1	74	16,09	40	6,75	10	7	8,3	17,8	19	.0251										
10 x 1	79	20,11	45	8,7	12	9	10,3	21,8	23,4	.0276										
10 x 1,25	79	20,11	45	8,4	12	8,75	10,3	22,2	23,8	.0277										
12 x 1	89	24,14	45	10,65	14	11	12,3	25,8	27,8	.0301										
12 x 1,25	89	23,88	45	10,4	14	10,75	12,3	25,9	27,9	.0302										
12 x 1,5	89	24,12	45	10,15	14	10,5	12,3	26,5	28,5	.0303										
14 x 1,5	102	27,14	48	12,1	16	12,5	14,3	29,6	31,8	.0331										
16 x 1,5	102	31,65	48	14,1	18	14,5	16,3	34,1	36,7	.0359										

Andere Abmessungen auf Anfrage Other sizes upon request

Product Finder

v_c / f_z

M

MF

UNC UN, UNS

UNF UNEF

G, Rp

NPT, NPTF Rc, W

BSW, BSF

Pg

EG (STI) SELF-LOCK

Tr

Zubehör Accessories

Tech. Info

BGF

ZBGF

GSF

GF

GF-KEG

ZGF

ZIRK-GF

Gigant

MoSys

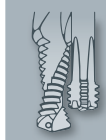

- Product Finder
- v_c / f_z
- M
- MF**
- UNC
UN, UNS
- UNF
UNEF
- G, Rp
- NPT, NPTF
Rc, W
- BSW, BSF
- Pg
- EG (STI)
SELF-LOCK
- Tr
- Zubehör
Accessories
- Tech. Info
- BGF**
- ZBGF
- GSF
- GF
- GF-KEG
- ZGF
- ZIRK-GF
- Gigant
- MoSys

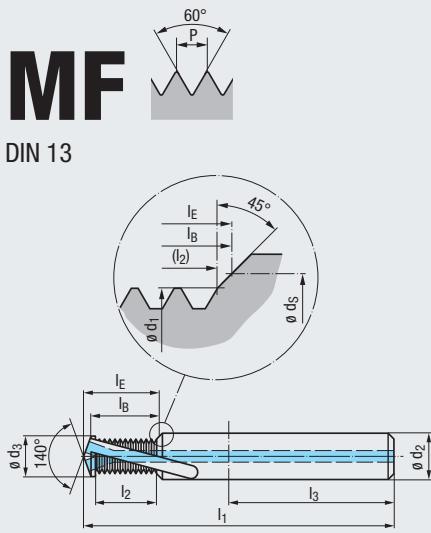

VHM	TICN
R20	RH + LH
Z4	DIN 6535 HB HE HA
90°	$\varnothing D$

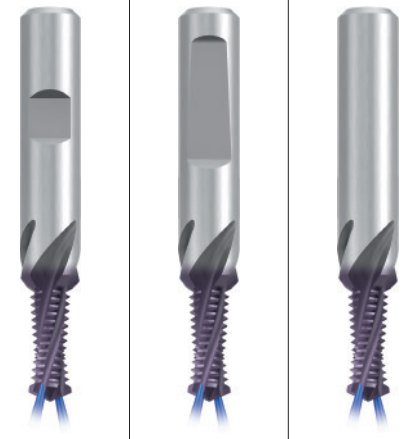

Einsatzgebiete – Material
Applications – material » 328

K 1.1-2 **N** 1.5-6, 2,3

Gewindetiefe
Thread depth

2 x D

Werkzeug-Ident · Tool ident

	GF439246	GF439546	GF439846
BGF-VHM-Z4 2xD R20-IKZ-HB TICN	●	●	●
BGF-VHM-Z4 2xD R20-IKZ-HE TICN	●	●	●
BGF-VHM-Z4 2xD R20-IKZ-HA TICN	●	●	●

	$\varnothing D$ mm	P mm	Dimens.- Ident									
			l_1	l_2	l_3	$\varnothing d_1$	$\varnothing d_2$	$\varnothing d_3$	$\varnothing d_S$	l_B	l_E	
M	8 x 1		74	16,09	40	6,75	10	7	8,3	17,8	19	.0251
	10 x 1		79	20,11	45	8,7	12	9	10,3	21,8	23,4	.0276
	12 x 1,5		89	24,12	45	10,15	14	10,5	12,3	26,5	28,5	.0303
	16 x 1,5		102	31,65	48	14,1	18	14,5	16,3	34,1	36,7	.0359

Andere Abmessungen auf Anfrage
Other sizes upon request

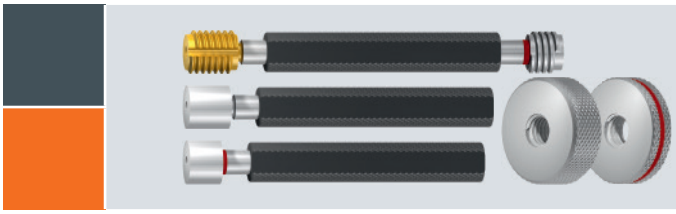
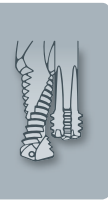

Gewindelehren
siehe Seite 581 - 654

Thread gauges,
see page 581 - 654

- Product Finder
- v_c / f_z
- M
- MF
- UNC**
UN, UNS
- UNF
UNEF
- G, Rp
- NPT, NPTF
Rc, W
- BSW, BSF
- Pg
- EG (STI)
SELF-LOCK
- Tr
- Zubehör
Accessories
- Tech. Info
- BGF**
- ZBGF
- GSF
- GF
- GF-KEG
- ZGF
- ZIRK-GF
- Gigant
- MoSys

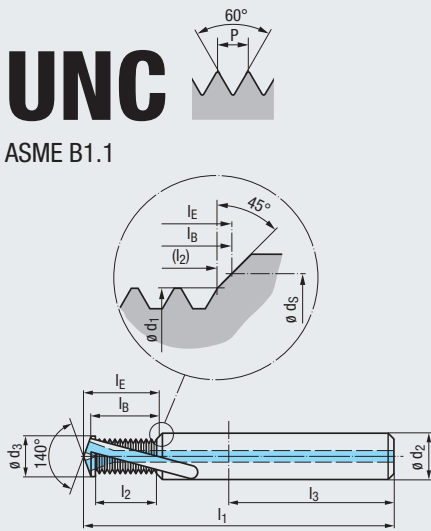

VHM

R30 **RH + LH**

Z2 **DIN 6535**
HB
HE
HA

90° **Ø D**

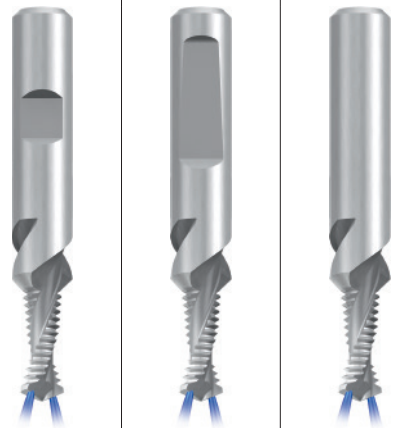

Einsatzgebiete – Material Applications – material **328**

K 1.1-3.2 **N 1.1-5**
N 2.2-3, 2.6 **N 3.1-2, 4.1**

Gewindetiefe Thread depth

1,5 x D

Werkzeug-Ident · Tool ident												GF422201	GF422501	GF422801
												BGF-VHM-Z2 1,5xD R30-IKZ-HB	BGF-VHM-Z2 1,5xD R30-IKZ-HE	BGF-VHM-Z2 1,5xD R30-IKZ-HA
Ø D inch	P Gg/1" (tpi)	l ₁	l ₂	l ₃	Ø d ₁	Ø d ₂	Ø d ₃	Ø d _S	l _B	l _E	Dimens.- Ident			
Nr. 12	24	62	7,50	36	4,21	8	4,5	5,79	9,2	10	.5008			
1/4	20	62	8,99	36	4,85	8	5,2	6,65	11,1	12	.5009	●	●	●
5/16	18	74	11,39	40	6,25	10	6,6	8,25	13,7	14,9	.5010	●	●	●
3/8	16	79	14,40	45	7,65	12	8	9,83	16,9	18,4	.5011	●	●	●
7/16	14	79	16,45	45	9	12	9,4	11,43	19,3	21	.5012	●	●	●
1/2	13	89	17,71	45	10,35	14	10,75	13	20,8	22,8	.5013	●	●	●
9/16	12	102	21,31	48	11,8	16	12,25	14,61	24,7	26,9	.5014	●	●	●
5/8	11	102	23,21	48	13,1	18	13,5	16,18	26,9	29,3	.5015	●	●	●
3/4	10	115	28,10	50	16	20	16,5	19,35	32,1	35,1	.5016	●	●	●

Gewindetiefe Thread depth

2 x D

Werkzeug-Ident · Tool ident												GF432201	GF432501	GF432801
												BGF-VHM-Z2 2xD R30-IKZ-HB	BGF-VHM-Z2 2xD R30-IKZ-HE	BGF-VHM-Z2 2xD R30-IKZ-HA
Ø D inch	P Gg/1" (tpi)	l ₁	l ₂	l ₃	Ø d ₁	Ø d ₂	Ø d ₃	Ø d _S	l _B	l _E	Dimens.- Ident			
Nr. 12	24	62	10,66	36	4,21	8	4,5	5,79	12,4	13,2	.5008			
1/4	20	62	12,80	36	4,85	8	5,2	6,65	14,9	15,8	.5009	●	●	●
5/16	18	74	15,63	40	6,25	10	6,6	8,25	17,9	19,1	.5010	●	●	●
3/8	16	79	19,16	45	7,65	12	8	9,83	21,7	23,2	.5011	●	●	●
7/16	14	79	21,89	45	9	12	9,4	11,43	24,8	26,5	.5012	●	●	●
1/2	13	89	25,52	45	10,35	14	10,75	13	28,6	30,6	.5013	●	●	●
9/16	12	102	27,66	48	11,8	16	12,25	14,61	31	33,2	.5014	●	●	●
5/8	11	102	30,14	48	13,1	18	13,5	16,18	33,8	36,2	.5015	●	●	●
3/4	10	115	38,26	50	16	20	16,5	19,35	42,2	45,2	.5016	●	●	●

Gewindetiefe Thread depth

2,5 x D

Werkzeug-Ident · Tool ident												GF442201	GF442501	GF442801
												BGF-VHM-Z2 2,5xD R30-IKZ-HB	BGF-VHM-Z2 2,5xD R30-IKZ-HE	BGF-VHM-Z2 2,5xD R30-IKZ-HA
Ø D inch	P Gg/1" (tpi)	l ₁	l ₂	l ₃	Ø d ₁	Ø d ₂	Ø d ₃	Ø d _S	l _B	l _E	Dimens.- Ident			
3/8	16	85	23,93	45	7,65	12	8	9,83	26,5	27,9	.5011	●	●	●
7/16	14	85	27,33	45	9	12	9,4	11,43	30,2	31,9	.5012	●	●	●
1/2	13	95	31,39	45	10,35	14	10,75	13	34,5	36,5	.5013	●	●	●
9/16	12	110	34,01	48	11,8	16	12,25	14,61	37,3	39,6	.5014	●	●	●
5/8	11	110	39,38	48	13,1	18	13,5	16,18	43	45,5	.5015	●	●	●
3/4	10	125	45,88	50	16	20	16,5	19,35	49,9	52,9	.5016	●	●	●

Andere Abmessungen auf Anfrage
Other sizes upon request

- Product Finder
- v_c / f_z
- M
- MF
- UNC
UN, UNS
- UNF**
UNEF
- G, Rp
- NPT, NPTF
Rc, W
- BSW, BSF
- Pg
- EG (STI)
SELF-LOCK
- Tr
- Zubehör
Accessories
- Tech. Info
- BGF
- ZBGF
- GSF
- GF
- GF-KEG
- ZGF
- ZIRK-GF
- Gigant
- MoSys

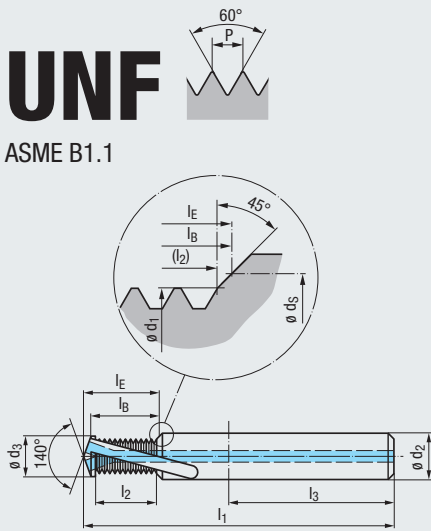

VHM

R30 **RH + LH**

Z2 **DIN 6535**
HB
HE
HA

90° **∅ D**

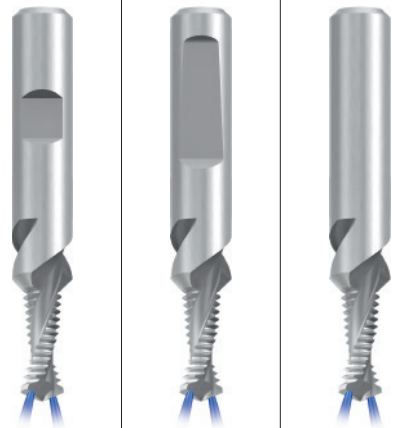

Einsatzgebiete – Material Applications – material ▶ 328

K 1.1-3.2 **N 1.1-5**
N 2.2-3, 2.6 **N 3.1-2, 4.1**

Gewindetiefe Thread depth

1,5 x D

Werkzeug-Ident · Tool ident

	GF422201	GF422501	GF422801
BGF-VHM-Z2 1,5xD R30-IKZ-HB		BGF-VHM-Z2 1,5xD R30-IKZ-HE	BGF-VHM-Z2 1,5xD R30-IKZ-HA
●	●	●	●
●	●	●	●
●	●	●	●
●	●	●	●
●	●	●	●
●	●	●	●
●	●	●	●
●	●	●	●

∅ D inch	P Gg/1" (tpi)	Dimens.-Ident												
		l_1	l_2	l_3	$\varnothing d_1$	$\varnothing d_2$	$\varnothing d_3$	$\varnothing d_S$	l_B	l_E				
Nr. 10	32	55	7,24	36	3,8	6	4,1	5,15	8,6	9,3	.5041			
Nr. 12	28	62	8,27	36	4,36	8	4,65	5,8	9,8	10,6	.5042			
1/4	28	62	9,16	36	5,26	8	5,5	6,65	10,6	11,6	.5043			
5/16	24	74	11,74	40	6,6	10	6,9	8,25	13,5	14,7	.5044	●	●	●
3/8	24	79	13,87	45	8,2	12	8,5	9,85	15,6	17,2	.5045	●	●	●
7/16	20	79	17,91	45	9,55	12	9,9	11,4	19,9	21,7	.5046	●	●	●
1/2	20	89	19,20	45	11,1	14	11,5	13	21,2	23,3	.5047	●	●	●
9/16	18	102	21,32	48	12,5	16	12,9	14,6	23,6	25,9	.5048	●	●	●
5/8	18	102	22,74	48	14,1	18	14,5	16,2	25	27,6	.5049	●	●	●
3/4	16	115	28,78	50	17	20	17,5	19,4	31,3	34,5	.5050			

Gewindetiefe Thread depth

2 x D

Werkzeug-Ident · Tool ident

	GF432201	GF432501	GF432801
BGF-VHM-Z2 2xD R30-IKZ-HB		BGF-VHM-Z2 2xD R30-IKZ-HE	BGF-VHM-Z2 2xD R30-IKZ-HA
●	●	●	●
●	●	●	●
●	●	●	●
●	●	●	●
●	●	●	●
●	●	●	●
●	●	●	●
●	●	●	●

∅ D inch	P Gg/1" (tpi)	Dimens.-Ident												
		l_1	l_2	l_3	$\varnothing d_1$	$\varnothing d_2$	$\varnothing d_3$	$\varnothing d_S$	l_B	l_E				
Nr. 10	32	55	9,63	36	3,8	6	4,1	5,15	11	11,7	.5041			
Nr. 12	28	62	10,99	36	4,36	8	4,65	5,8	12,5	13,3	.5042			
1/4	28	62	12,79	36	5,26	8	5,5	6,65	14,3	15,3	.5043			
5/16	24	74	15,98	40	6,6	10	6,9	8,25	17,7	19	.5044	●	●	●
3/8	24	79	19,16	45	8,2	12	8,5	9,85	20,9	22,4	.5045	●	●	●
7/16	20	79	21,72	45	9,55	12	9,9	11,4	23,8	25,5	.5046	●	●	●
1/2	20	89	25,55	45	11,1	14	11,5	13	27,6	29,7	.5047	●	●	●
9/16	18	102	28,37	48	12,5	16	12,9	14,6	30,6	33	.5048	●	●	●
5/8	18	102	31,21	48	14,1	18	14,5	16,2	33,5	36,1	.5049	●	●	●
3/4	16	115	38,31	50	17	20	17,5	19,4	40,9	44,1	.5050			

Andere Abmessungen auf Anfrage Other sizes upon request

- Product Finder
- v_c / f_z
- M
- MF
- UNC
UN, UNS
- UNF
UNEF
- G Rp
- NPT, NPTF
Rc, W
- BSW, BSF
- Pg
- EG (STI)
SELF-LOCK
- Tr
- Zubehör
Accessories
- Tech. Info
- BGF
- ZBGF
- GSF
- GF
- GF-KEG
- ZGF
- ZIRK-GF
- Gigant
- MoSys

G (BSP)

DIN EN ISO 228

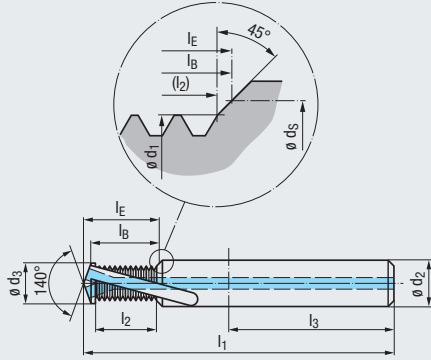

VHM

R30 **RH + LH**

Z2 **DIN 6535**
HB
HE
HA

90° **∅ D**

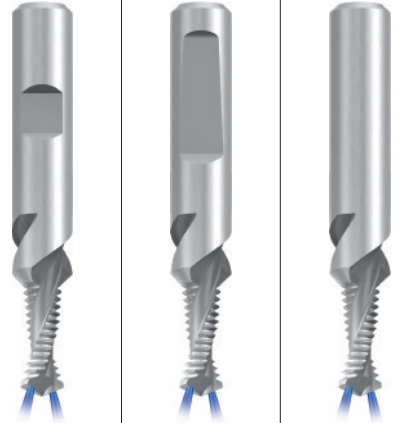

Einsatzgebiete – Material
Applications – material

K 1.1-3.2 **N 1.1-5**
N 2.2-3, 2.6 **N 3.1-2, 4.1**

Gewindetiefe
Thread depth

1,5 x D

Werkzeug-Ident · Tool ident

	GF422201	GF422501	GF422801
BGF-VHM-Z2 1,5xD R30-IKZ-HB	●	●	●
BGF-VHM-Z2 1,5xD R30-IKZ-HE	●	●	●
BGF-VHM-Z2 1,5xD R30-IKZ-HA	●	●	●

Nenngröße
Nom. size

∅ D	P Gg/1" (tpi)	Dimens.-Ident									
		l_1	l_2	l_3	$\emptyset d_1$	$\emptyset d_2$	$\emptyset d_3$	$\emptyset d_5$	l_B	l_E	
G 1/8	28	79	14,56	45	8,5	12	8,8	10	16,1	17,7	.4035
1/4	19	102	18,77	48	11,4	16	11,8	13,5	21	23,1	.4036
3/8	19	102	25,46	48	14,85	18	15,25	17	27,7	30,5	.4037

Gewindetiefe
Thread depth

2 x D

Werkzeug-Ident · Tool ident

	GF432201	GF432501	GF432801
BGF-VHM-Z2 2xD R30-IKZ-HB	●	●	●
BGF-VHM-Z2 2xD R30-IKZ-HE	●	●	●
BGF-VHM-Z2 2xD R30-IKZ-HA	●	●	●

Nenngröße
Nom. size

∅ D	P Gg/1" (tpi)	Dimens.-Ident									
		l_1	l_2	l_3	$\emptyset d_1$	$\emptyset d_2$	$\emptyset d_3$	$\emptyset d_5$	l_B	l_E	
G 1/8	28	79	19,10	45	8,5	12	8,8	10	20,6	22,2	.4035
1/4	19	102	25,46	48	11,4	16	11,8	13,5	27,7	29,8	.4036
3/8	19	102	33,48	48	14,85	18	15,25	17	35,7	38,5	.4037

Andere Abmessungen auf Anfrage
Other sizes upon request



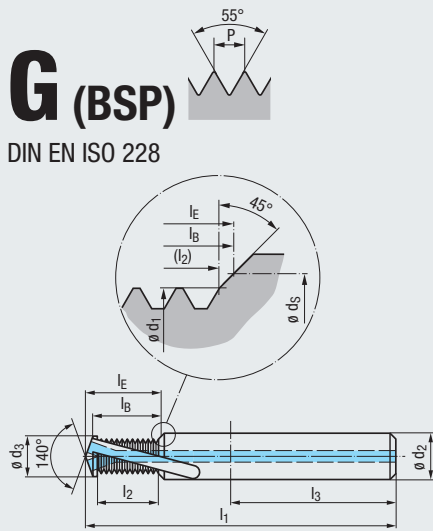

VHM	TICN
R30	RH + LH
Z2	DIN 6535 HB HE HA
90°	θD

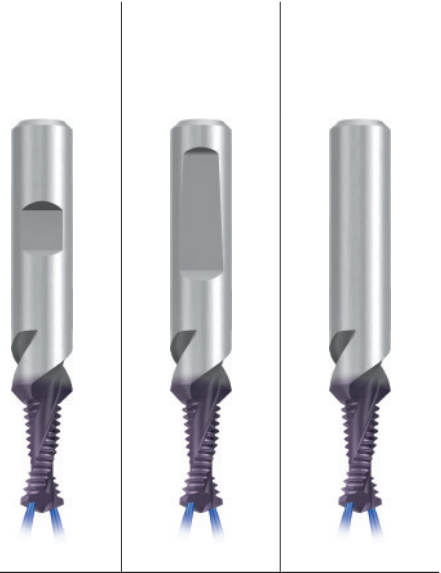

Product Finder

v_c / f_z

M

MF

UNC
UN, UNS

UNF
UNEF

G, Rp

NPT, NPTF
Rc, W

BSW, BSF

Pg

EG (STI)
SELF-LOCK

Tr

Zubehör
Accessories

Tech. Info

BGF

ZBGF

GSF

GF

GF-KEG

ZGF

ZIRK-GF

Gigant

MoSys

Einsatzgebiete – Material Applications – material **328**

K 1.1-3.2 N 1.1-6
N 2.2-3, 2.6 N 3.1-2, 4.1

Gewindetiefe Thread depth

1,5 x D

Werkzeug-Ident · Tool ident												GF422206	GF422506	GF422806
Nenngröße Nom. size											Dimens.-Ident	BGF-VHM-Z2 1,5xD R30-1KZ-HB TICN	BGF-VHM-Z2 1,5xD R30-1KZ-HE TICN	BGF-VHM-Z2 1,5xD R30-1KZ-HA TICN
θD	P Gg/1" (tpi)	l_1	l_2	l_3	θd_1	θd_2	θd_3	θd_s	l_b	l_e				
G 1/8	28	79	14,56	45	8,5	12	8,8	10	16,1	17,7	.4035	●	●	●
1/4	19	102	18,77	48	11,4	16	11,8	13,5	21	23,1	.4036	●	●	●
3/8	19	102	25,46	48	14,85	18	15,25	17	27,7	30,5	.4037	●	●	●

Gewindetiefe Thread depth

2 x D

Werkzeug-Ident · Tool ident												GF432206	GF432506	GF432806
Nenngröße Nom. size											Dimens.-Ident	BGF-VHM-Z2 2xD R30-1KZ-HB TICN	BGF-VHM-Z2 2xD R30-1KZ-HE TICN	BGF-VHM-Z2 2xD R30-1KZ-HA TICN
θD	P Gg/1" (tpi)	l_1	l_2	l_3	θd_1	θd_2	θd_3	θd_s	l_b	l_e				
G 1/8	28	79	19,10	45	8,5	12	8,8	10	20,6	22,2	.4035	●	●	●
1/4	19	102	25,46	48	11,4	16	11,8	13,5	27,7	29,8	.4036	●	●	●
3/8	19	102	33,48	48	14,85	18	15,25	17	35,7	38,5	.4037	●	●	●

Andere Abmessungen auf Anfrage Other sizes upon request



Gewinde-Tiefenlehndorne siehe Seite 624 - 627

Thread depth plug gauges, see page 624 - 627

● = Lagerwerkzeug, siehe Preisliste · Stock tool, see price list
○ = Kurzfristig lieferbar, Preis auf Anfrage · Available on short notice, price upon inquiry

- Product Finder
- v_c / f_z
- M
- MF
- UNC
UN, UNS
- UNF
UNEF
- G, Rp
- NPT, NPTF
Rc, W
- BSW, BSF
- Pg
- EG (STI)
SELF-LOCK
- Tr
- Zubehör
Accessories
- Tech. Info
- BGF
- ZBGF
- GSF
- GF
- GF-KEG
- ZGF
- ZIRK-GF
- Gigant
- MoSys

EG M (STI)

DIN 8140-2

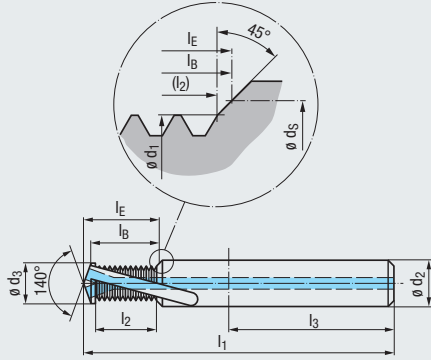
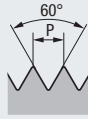

VHM

R30 **RH + LH**

Z2 **DIN 6535**
 HB
 HE
 HA

90° **Ø D**

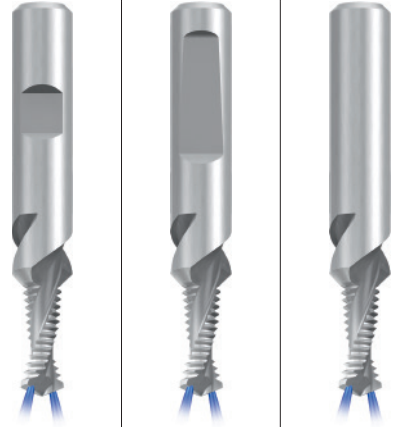

Einsatzgebiete – Material Applications – material **328**

K 1.1-3.2 **N 1.1-5**
N 2.2-3, 2.6 **N 3.1-2, 4.1**

Gewindetiefe Thread depth

1,5 x D

Werkzeug-Ident · Tool ident

	GF422201	GF422501	GF422801
BGF-VHM-Z2 1,5xD R30-IKZ-HB	●	●	●
BGF-VHM-Z2 1,5xD R30-IKZ-HE	●	●	●
BGF-VHM-Z2 1,5xD R30-IKZ-HA	●	●	●

Nenngröße Nom. size

Ø D	P mm	Dimens.-Ident									
		l_1	l_2	l_3	$\varnothing d_1$	$\varnothing d_2$	$\varnothing d_3$	$\varnothing d_5$	l_B	l_E	
EG M 6	1	74	10,10	40	6	10	6,3	7,6	11,8	12,9	.0971
8	1,25	79	12,60	45	8,1	12	8,4	9,9	14,6	16,1	.0973
10	1,5	89	16,63	45	10	14	10,4	12,25	19,1	21	.0975
12	1,75	102	19,38	48	12,1	16	12,5	14,6	22,2	24,5	.0977
14	2	102	22,12	48	14,1	18	14,5	16,9	25,3	28	.0978
16	2	115	26,17	50	16	20	16,5	18,9	29,4	32,4	.0979

Gewindetiefe Thread depth

2 x D

Werkzeug-Ident · Tool ident

	GF432201	GF432501	GF432801
BGF-VHM-Z2 2xD R30-IKZ-HB	●	●	●
BGF-VHM-Z2 2xD R30-IKZ-HE	●	●	●
BGF-VHM-Z2 2xD R30-IKZ-HA	●	●	●

Nenngröße Nom. size

Ø D	P mm	Dimens.-Ident									
		l_1	l_2	l_3	$\varnothing d_1$	$\varnothing d_2$	$\varnothing d_3$	$\varnothing d_5$	l_B	l_E	
EG M 6	1	74	13,10	40	6	10	6,3	7,6	14,8	15,9	.0971
8	1,25	79	16,35	45	8,1	12	8,4	9,9	18,4	19,9	.0973
10	1,5	89	21,13	45	10	14	10,4	12,25	23,6	25,5	.0975
12	1,75	102	24,63	48	12,1	16	12,5	14,6	27,5	29,7	.0977
14	2	102	30,12	48	14,1	18	14,5	16,9	33,3	36	.0978
16	2	115	34,17	50	16	20	16,5	18,9	37,4	40,4	.0979

Andere Abmessungen auf Anfrage Other sizes upon request

EG M (STI)

DIN 8140-2

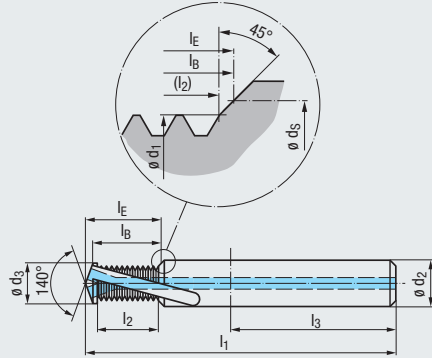

VHM	TICN
R30	RH + LH
Z2	DIN 6535 HB HE HA
90°	ø D

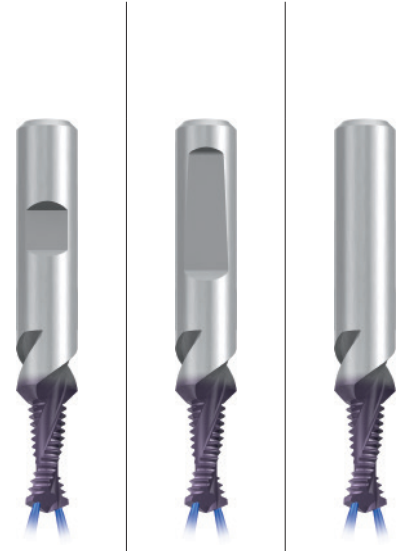

- Product Finder
- v_c / f_z
- M
- MF
- UNC UN, UNS
- UNF UNEF
- G, Rp
- NPT, NPTF Rc, W
- BSW, BSF
- Pg
- EG (STI) SELF-LOCK

Einsatzgebiete – Material Applications – material ▶ 328

K 1.1-3.2 **N** 1.1-6
N 2.2-3, 2.6 **N** 3.1-2, 4.1

Gewindetiefe Thread depth

1,5 x D

Werkzeug-Ident · Tool ident												GF422206	GF422506	GF422806
Nenngröße Nom. size											Dimens.-Ident	BGF-VHM-Z2 1,5xD R30-IKZ-HB TICN	BGF-VHM-Z2 1,5xD R30-IKZ-HE TICN	BGF-VHM-Z2 1,5xD R30-IKZ-HA TICN
ø D	P mm	l ₁	l ₂	l ₃	ø d ₁	ø d ₂	ø d ₃	ø d _S	l _B	l _E				
EG M 6	1	74	10,10	40	6	10	6,3	7,6	11,8	12,9	.0971	●	●	●
8	1,25	79	12,60	45	8,1	12	8,4	9,9	14,6	16,1	.0973	●	●	●
10	1,5	89	16,63	45	10	14	10,4	12,25	19,1	21	.0975	●	●	●
12	1,75	102	19,38	48	12,1	16	12,5	14,6	22,2	24,5	.0977	●	●	●
14	2	102	22,12	48	14,1	18	14,5	16,9	25,3	28	.0978	●	●	●
16	2	115	26,17	50	16	20	16,5	18,9	29,4	32,4	.0979	●	●	●

Gewindetiefe Thread depth

2 x D

Werkzeug-Ident · Tool ident												GF432206	GF432506	GF432806
Nenngröße Nom. size											Dimens.-Ident	BGF-VHM-Z2 2xD R30-IKZ-HB TICN	BGF-VHM-Z2 2xD R30-IKZ-HE TICN	BGF-VHM-Z2 2xD R30-IKZ-HA TICN
ø D	P mm	l ₁	l ₂	l ₃	ø d ₁	ø d ₂	ø d ₃	ø d _S	l _B	l _E				
EG M 6	1	74	13,10	40	6	10	6,3	7,6	14,8	15,9	.0971	●	●	●
8	1,25	79	16,35	45	8,1	12	8,4	9,9	18,4	19,9	.0973	●	●	●
10	1,5	89	21,13	45	10	14	10,4	12,25	23,6	25,5	.0975	●	●	●
12	1,75	102	24,63	48	12,1	16	12,5	14,6	27,5	29,7	.0977	●	●	●
14	2	102	30,12	48	14,1	18	14,5	16,9	33,3	36	.0978	●	●	●
16	2	115	34,17	50	16	20	16,5	18,9	37,4	40,4	.0979	●	●	●

Andere Abmessungen auf Anfrage Other sizes upon request

- Tr
- Zubehör Accessories
- Tech. Info
- BGF
- ZBGF
- GSF
- GF
- GF-KEG
- ZGF
- ZIRK-GF
- Gigant
- MoSys

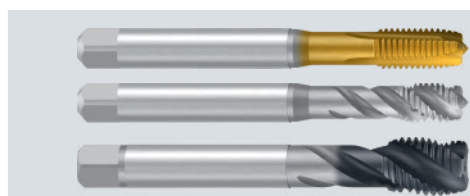

Gewindebohrer für Metrisches EG-Gewinde siehe Seite 216 - 219

Taps for Metric STI thread, see page 216 - 219

● = Lagerwerkzeug, siehe Preisliste · Stock tool, see price list
○ = Kurzfristig lieferbar, Preis auf Anfrage · Available on short notice, price upon inquiry

- Product Finder
- v_c / f_z
- M
- MF
- UNC
UN, UNS
- UNF
UNEF
- G, Rp
- NPT, NPTF
Rc, W
- BSW, BSF
- Pg
- EG (STI)
SELF-LOCK
- Tr
- Zubehör
Accessories
- Tech. Info
- BGF**
- ZBGF
- GSF
- GF
- GF-KEG
- ZGF
- ZIRK-GF
- Gigant
- MoSys
- 



Für die Bearbeitung von Aluminium und Grauguss
For the machining of aluminium and cast iron

ZBGF-T

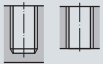

Für die Hartbearbeitung
For hard materials

ZBGF-H

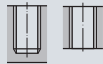

Für die Weichbearbeitung
For soft/unhardened materials

ZBGF-W

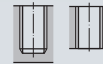

Seite · Page

354	355	355	M, MF
	356	356	UNC
	357	357	UNF

Product
Finder

v_c / f_z

M

MF

UNC
UN, UNS

UNF
UNEF

G, Rp

NPT, NPTF
Rc, W

BSW, BSF

Pg

EG (STI)
SELF-LOCK

Tr

Zubehör
Accessories

Tech. Info

BGF

ZBGF

GSF

GF

GF-KEG

ZGF

ZIRK-GF

Gigant

MoSys



Gewindefräszyklus · Thread milling cycle

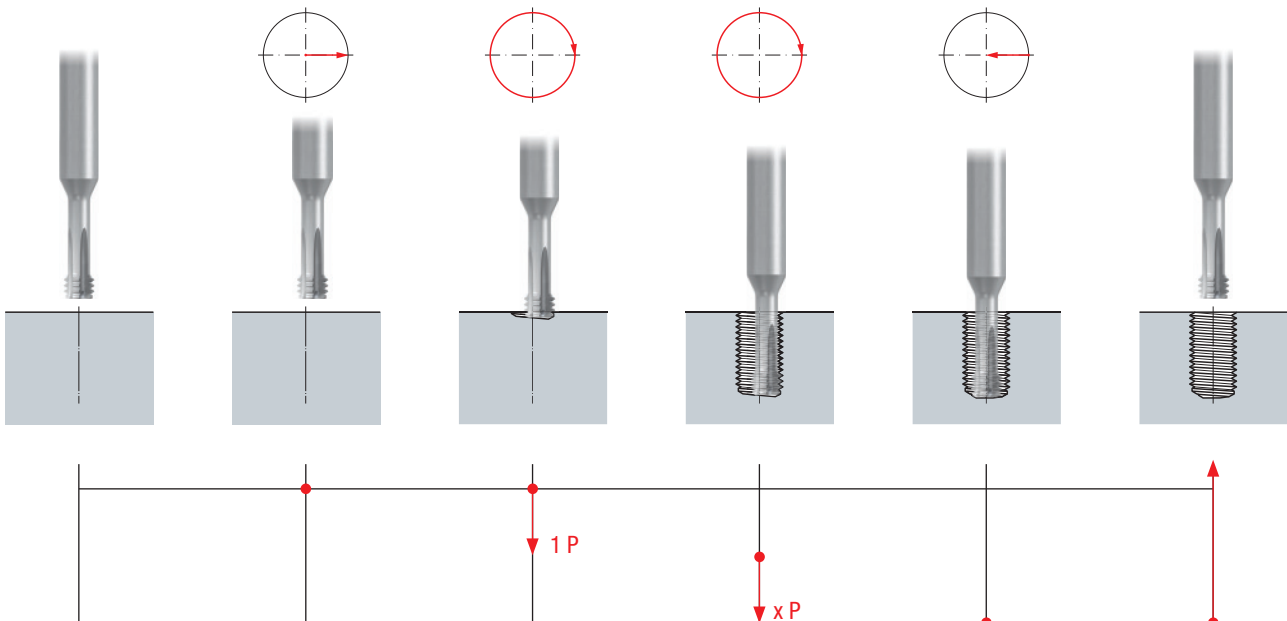

- Product Finder
- v_c / f_z
- M
- MF
- UNC
UN, UNS
- UNF
UNEF
- G, Rp
- NPT, NPTF
Rc, W
- BSW, BSF
- Pg
- EG (STI)
SELF-LOCK
- Tr
- Zubehör
Accessories
- Tech. Info
- BGF
- ZBGF
- GSF
- GF
- GF-KEG
- ZGF
- ZIRK-GF
- Gigant
- MoSys

M, MF

DIN 13

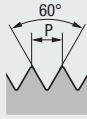

VHM

TICN

RH + LH

RH-rot.

Z3 - Z4

DIN 6535
 HB
 HE
 HA

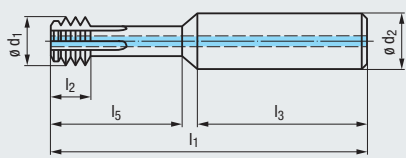

ZBGF-T
Für die Bearbeitung von Aluminium und Grauguss
For the machining of aluminium and cast iron

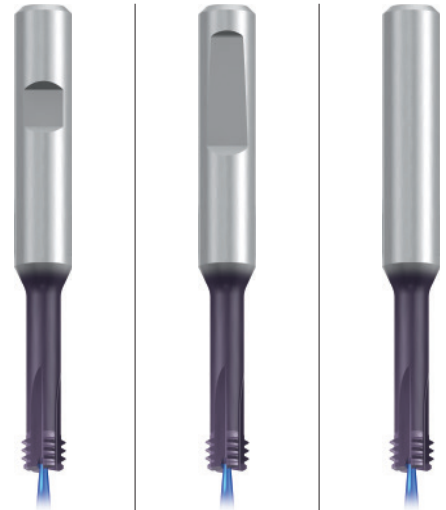

K 1.1-2 **N** 1.1-6, 3.1-2

Einsatzgebiete – Material
Applications – material 328

Gewindetiefe
Thread depth

3 x D

Werkzeug-Ident · Tool ident

P mm	$\varnothing D$	l_1	l_2	l_3	l_5	$\varnothing d_1$	$\varnothing d_2$	Z	Dimens.- Ident	GF753276	GF753576	GF753876
										ZBGF-T-VHM 3xD IKZ-HB TICN	ZBGF-T-VHM 3xD IKZ-HE TICN	ZBGF-T-VHM 3xD IKZ-HA TICN
1	M 6 - M 7	65	4	36	20	4,5	8	3	.0060	●	●	●
1,25	M 8 - M10 x 1,25	80	5	40	27	6,2	10	4	.0080	●	●	●
1,5	M10 - M12 x 1,5	85	6	40	34	7,75	10	4	.0100	●	●	●
1,75	M12	100	7	45	39	9,2	12	4	.0112	●	●	●

Andere Abmessungen auf Anfrage
Other sizes upon request

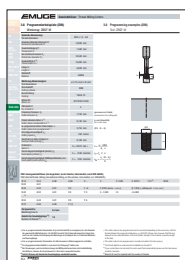

Programmierbeispiel für
Zirkular-Bohrgewindefräser Typ ZBGF
siehe Seite 464

Programming example for
circular drill thread mills type ZBGF,
see page 464

M, MF

DIN 13

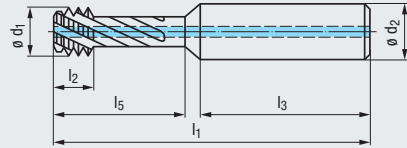
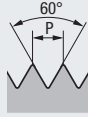

VHM	TIALN T4
RH + LH	RH-rot.
R30	Z3 - Z4
DIN 6535 HB HE HA	ø D

ZBGF-W

Für die Weichbearbeitung
For soft/unhardened materials

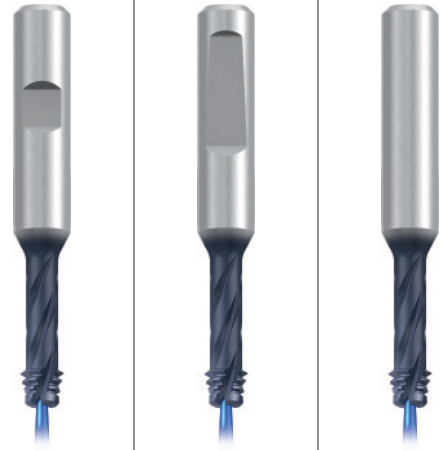

P 1.1-5.1	M 1.1-4.1	K 1.1-4.2
N 1.1-6, 2.1-6	N 3.1-2	N 4.1, 4.3-4
S 1.1-3	S 2.1-2, 2.4	H 1.1-2

Einsatzgebiete – Material
Applications – material

Gewindetiefe
Thread depth

Werkzeug-Ident · Tool ident

P mm	ø D	l ₁	l ₂	l ₃	l ₅	ø d ₁	ø d ₂	Z	Dimens.-Ident
1	M 6 - M 7	60	4,6	36	16	4,51	8	3	.0060
1,25	M 8 - M10 x 1,25	71	5,7	40	21	6,23	10	4	.0080
1,5	M10 - M12 x 1,5	76	6,9	40	26	7,75	10	4	.0100
1,75	M12	86	7,9	45	32	9,16	12	4	.0112
2	M14 - M16	98	9,1	48	41	11,08	16	4	.0114

2 x D

GF732257	GF732557	GF732857
ZBGF-W-VHM 2xD R30-İKZ-HB TIALN-T4	ZBGF-W-VHM 2xD R30-İKZ-HE TIALN-T4	ZBGF-W-VHM 2xD R30-İKZ-HA TIALN-T4
●	●	●
●	●	●
●	●	●
●	●	●
●	●	●

M, MF

DIN 13

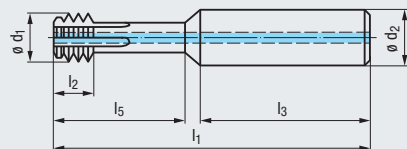
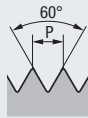

VHM	TIALN T3
RH	LH-rot.
	Z4
DIN 6535 HB HE HA	ø D

ZBGF-H

Für die Hartbearbeitung
For hard materials

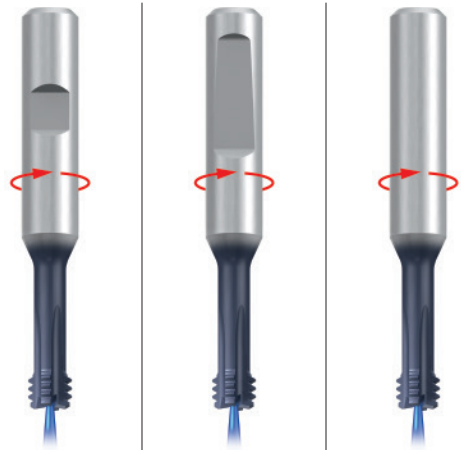

N 2.7-8	H 1.1-5
---------	---------

Einsatzgebiete – Material
Applications – material

Gewindetiefe
Thread depth

Werkzeug-Ident · Tool ident

P mm	ø D	l ₁	l ₂	l ₃	l ₅	ø d ₁	ø d ₂	Z	Dimens.-Ident
1,25	M 8 - M10 x 1,25	71	5	40	19	6,2	10	4	.0080
1,5	M10 - M12 x 1,5	76	6	40	25	7,75	10	4	.0100
1,75	M12	86	7	45	31	9,2	12	4	.0112
2	M14 - M16	98	8	48	36	11,1	16	4	.0114

2 x D

GF733208	GF733508	GF733808
ZBGF-H-VHM 2xD IKZ-HB TIALN-T3	ZBGF-H-VHM 2xD IKZ-HE TIALN-T3	ZBGF-H-VHM 2xD IKZ-HA TIALN-T3
●	●	●
●	●	●
●	●	●
●	●	●
●	●	●

Andere Abmessungen auf Anfrage
Other sizes upon request

- Product Finder
- v_c / f_z
- M
- MF
- UNC**
UN, UNS
- UNF
UNEF
- G, Rp
- NPT, NPTF
Rc, W
- BSW, BSF
- Pg
- EG (STI)
SELF-LOCK
- Tr
- Zubehör
Accessories
- Tech. Info
- BGF
- ZBGF**
- GSF
- GF
- GF-KEG
- ZGF
- ZIRK-GF
- Gigant
- MoSys

UNC

ASME B1.1

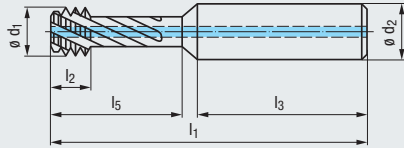
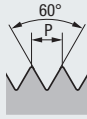

VHM	TIALN T4
RH + LH	RH-rot.
R30	Z3 - Z5
DIN 6535 HB HE HA	$\varnothing D$

ZBGF-W
Für die Weichbearbeitung
For soft/unhardened materials

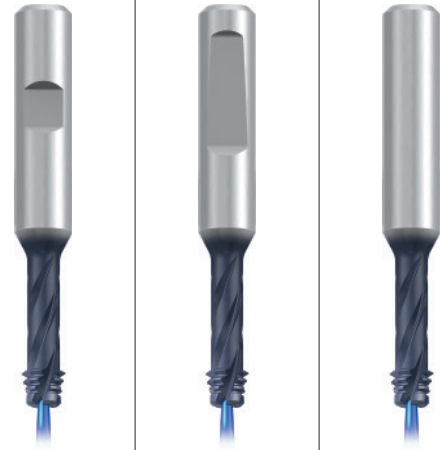

- | | | |
|----------------|--------------|--------------|
| P 1.1-5.1 | M 1.1-4.1 | K 1.1-4.2 |
| N 1.1-6, 2.1-6 | N 3.1-2 | N 4.1, 4.3-4 |
| S 1.1-3 | S 2.1-2, 2.4 | H 1.1-2 |

Einsatzgebiete – Material
Applications – material [» 328](#)

Gewindetiefe
Thread depth

2 x D

Werkzeug-Ident · Tool ident

$\varnothing D$ inch	P Gg/1" (tpi)	l_1	l_2	l_3	l_5	$\varnothing d_1$	$\varnothing d_2$	Z	Dimens.- Ident	GF732257	GF732557	GF732857
										ZBGF-W-VHM 2xD R30-IKZ-HB TIALN-T4	ZBGF-W-VHM 2xD R30-IKZ-HE TIALN-T4	ZBGF-W-VHM 2xD R30-IKZ-HA TIALN-T4
1/4	20	60	5,8	36	17	4,64	8	3	.5009	•	•	•
5/16	18	76	6,4	40	22	5,64	10	4	.5010	•	•	•
3/8	16	76	7,2	40	26	7,16	10	4	.5011	•	•	•
7/16	14	86	8,1	45	31	8,47	12	4	.5012	•	•	•
1/2	13	86	8,9	45	33	10,08	12	4	.5013	•	•	•
5/8	11	98	10,4	48	42	12,89	16	4	.5015	•	•	•
3/4	10	111	11,4	50	51	15,5	20	5	.5016	•	•	•

UNC

ASME B1.1

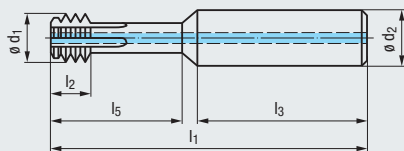
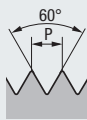

VHM	TIALN T3
RH	LH-rot.
	Z4 - Z5
DIN 6535 HB HE HA	$\varnothing D$

ZBGF-H
Für die Hartbearbeitung
For hard materials

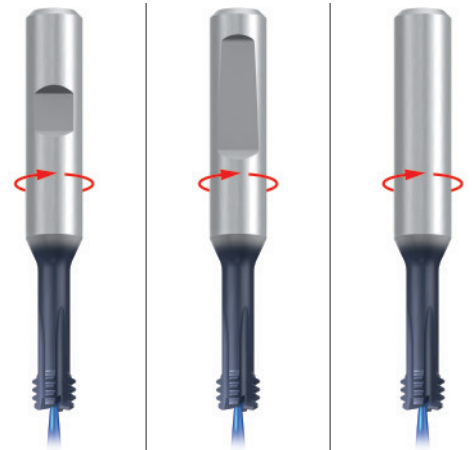

- | | |
|---------|---------|
| N 2.7-8 | H 1.1-5 |
|---------|---------|

Einsatzgebiete – Material
Applications – material [» 328](#)

Gewindetiefe
Thread depth

2 x D

Werkzeug-Ident · Tool ident

$\varnothing D$ inch	P Gg/1" (tpi)	l_1	l_2	l_3	l_5	$\varnothing d_1$	$\varnothing d_2$	Z	Dimens.- Ident	GF733208	GF733508	GF733808
										ZBGF-H-VHM 2xD IKZ-HB TIALN-T3	ZBGF-H-VHM 2xD IKZ-HE TIALN-T3	ZBGF-H-VHM 2xD IKZ-HA TIALN-T3
5/16	18	76	5,6	40	22	5,64	10	4	.5010	•	•	•
3/8	16	76	6,4	40	27	7,16	10	4	.5011	•	•	•
7/16	14	86	7,3	45	31	8,47	12	4	.5012	•	•	•
1/2	13	86	7,8	45	33	10,08	12	4	.5013	•	•	•
5/8	11	98	9,2	48	42	12,89	16	4	.5015	•	•	•
3/4	10	111	10,2	50	51	15,5	20	5	.5016	•	•	•

UNF

ASME B1.1

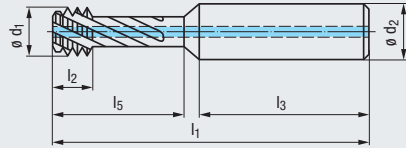

VHM **TIALN T4**

RH + LH **RH-rot.**

R30 **Z3 - Z5**

DIN 6535
HB HE HA

ZBGF-W

Für die Weichbearbeitung
For soft/unhardened materials

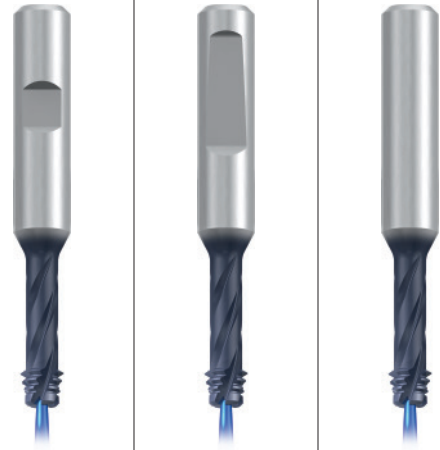

- P** 1.1-5.1 **M** 1.1-4.1 **K** 1.1-4.2
- N** 1.1-6, 2.1-6 **N** 3.1-2 **N** 4.1, 4.3-4
- S** 1.1-3 **S** 2.1-2, 2.4 **H** 1.1-2

Einsatzgebiete – Material Applications – material [» 328](#)

Gewindetiefe Thread depth

Werkzeug-Ident · Tool ident										Dimens.-Ident
ø D inch	P Gg/1" (tpi)	l ₁	l ₂	l ₃	l ₅	ø d ₁	ø d ₂	Z		
1/4	28	60	4,2	36	17	4,66	8	3	.5043	
5/16	24	76	4,8	40	22	5,64	10	4	.5044	
3/8	24	76	4,8	40	26	7,14	10	4	.5045	
7/16 - 1/2	20	86	5,8	45	33	8,45	12	4	.5046	
9/16 - 5/8	18	98	6,4	48	41	11,27	16	4	.5048	
3/4	16	111	7,2	50	51	15,38	20	5	.5050	

2 x D

GF732257	GF732557	GF732857
ZBGF-W-VHM 2xD R30- IKZ-HB TIALN-T4	ZBGF-W-VHM 2xD R30- IKZ-HE TIALN-T4	ZBGF-W-VHM 2xD R30- IKZ-HA TIALN-T4
•	•	•
•	•	•
•	•	•
•	•	•
•	•	•
•	•	•

UNF

ASME B1.1

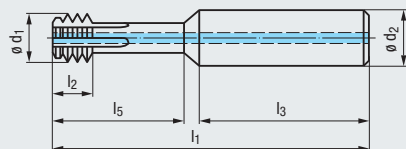
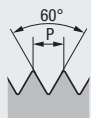

VHM **TIALN T3**

RH **LH-rot.**

Z4 - Z5

DIN 6535
HB HE HA

ZBGF-H

Für die Hartbearbeitung
For hard materials

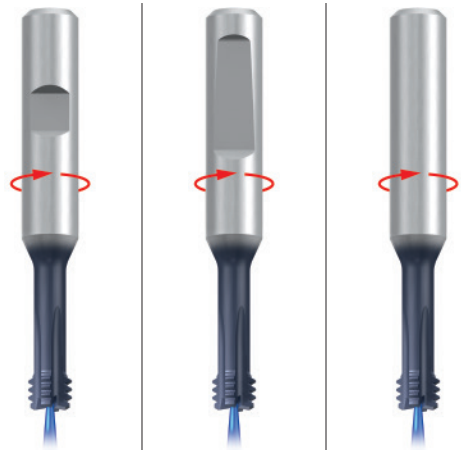

- N** 2.7-8 **H** 1.1-5

Einsatzgebiete – Material Applications – material [» 328](#)

Gewindetiefe Thread depth

Werkzeug-Ident · Tool ident										Dimens.-Ident
ø D inch	P Gg/1" (tpi)	l ₁	l ₂	l ₃	l ₅	ø d ₁	ø d ₂	Z		
5/16	24	76	4,2	40	22	5,64	10	4	.5044	
3/8	24	76	4,2	40	27	7,14	10	4	.5045	
7/16 - 1/2	20	86	5,1	45	33	8,45	12	4	.5046	
9/16 - 5/8	18	98	5,6	48	41	11,27	16	4	.5048	
3/4	16	111	6,4	50	51	15,38	20	5	.5050	

2 x D

GF733208	GF733508	GF733808
ZBGF-H-VHM 2xD IKZ-HB TIALN-T3	ZBGF-H-VHM 2xD IKZ-HE TIALN-T3	ZBGF-H-VHM 2xD IKZ-HA TIALN-T3
•	•	•
•	•	•
•	•	•
•	•	•
•	•	•
•	•	•

● = Lagerwerkzeug, siehe Preisliste · Stock tool, see price list
○ = Kurzfristig lieferbar, Preis auf Anfrage · Available on short notice, price upon inquiry

Andere Abmessungen auf Anfrage
Other sizes upon request

Product Finder

v_c / f_z

M

MF

UNC UN, UNS

UNF UNEF

G, Rp

NPT, NPTF Rc, W

BSW, BSF

Pg

EG (STI) SELF-LOCK

Tr

Zubehör Accessories

Tech. Info

BGF

ZBGF

GSF

GF

GF-KEG

ZGF

ZIRK-GF

Gigant

MoSys

- Product Finder
- v_c / f_z
- M
- MF
- UNC
UN, UNS
- UNF
UNEF
- G, Rp
- NPT, NPTF
Rc, W
- BSW, BSF
- Pg
- EG (STI)
SELF-LOCK
- Tr
- Zubehör
Accessories
- Tech. Info
- BGF
- ZBGF
- GSF**
- GF
- GF-KEG
- ZGF
- ZIRK-GF
- Gigant
- MoSys

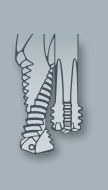

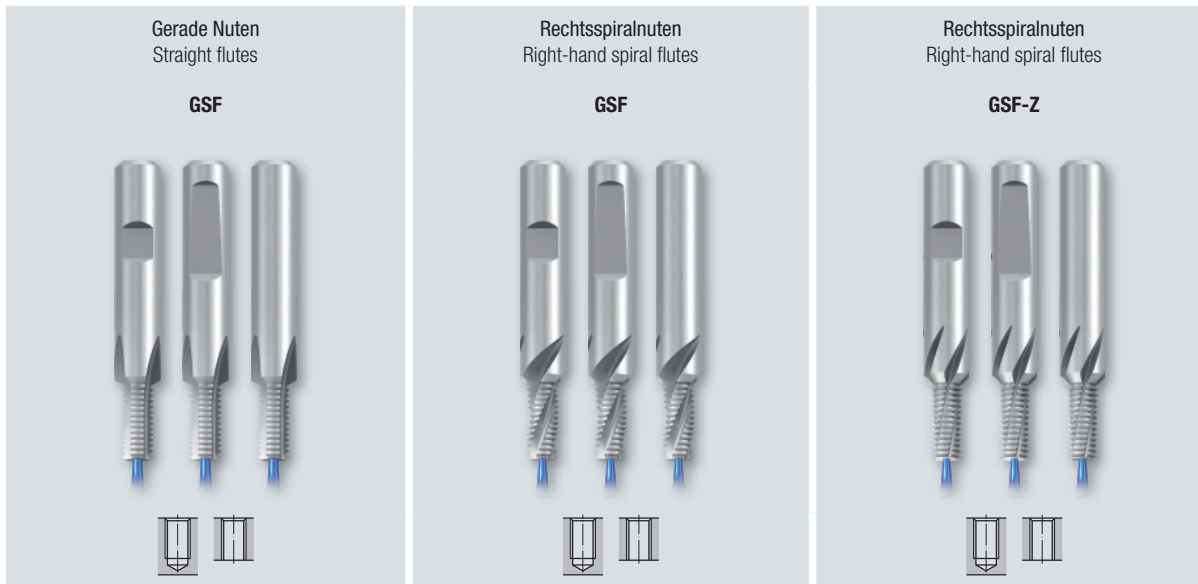

Product Finder

v_c / f_z

M

MF

UNC
UN, UNS

UNF
UNEF

G, Rp

NPT, NPTF
Rc, W

BSW, BSF

Pg

EG (STI)
SELF-LOCK

Tr

Zubehör
Accessories

Tech. Info

BGF

ZBGF

GSF

GF

GF-KEG

ZGF

ZIRK-GF







Gigant

MoSys



360 - 361	362 - 363	364 - 365	M
366 - 367	368 - 369	370 - 371	MF
	372 - 373		UNC
	374 - 375		UNF
	376 - 377		G (BSP)
378 - 379			LK-M

Mögliche Modifikationen · Possible modifications

-  Stirnfase ohne/mit Stirnschnitt
Face chamfer with/without cutting face
-  Unvollständigen Gang entfernen
Remove incomplete thread
-  Halsfreischliff
Recessed neck
-  AZR/AZ (ausgesetzte Zähne)
AZR/AZ (alternating teeth)
-  IKZN (innere Kühlschmierstoff-Zufuhr mit Austritt in den Nuten)
IKZN (internal coolant supply exiting in the flutes)
-  Schaftkühlfluten
Coolant grooves along the shank

Eine Beschreibung dieser Modifikationsmöglichkeiten finden Sie auf Seite 456 - 457
For a description of these modifications, see pages 456 - 457

Gewindefräszyklus · Thread milling cycle

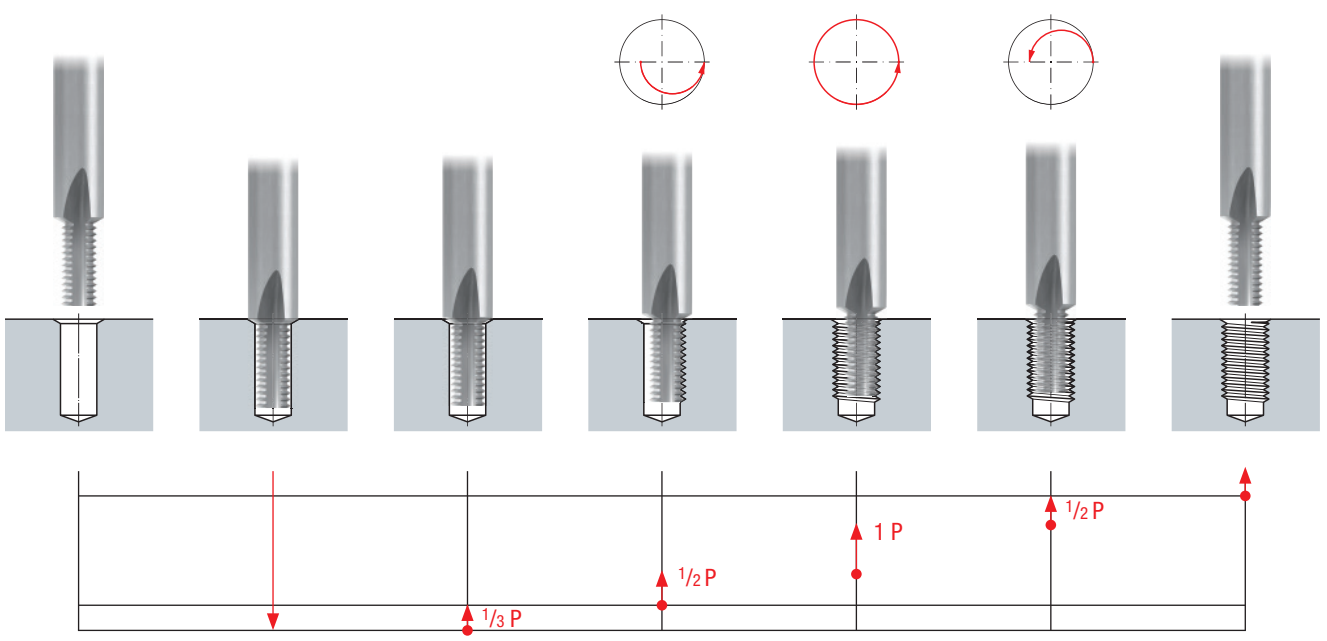

Product Finder

v_c / f_z

M

MF

UNC
UN, UNS

UNF
UNEF

G, Rp

NPT, NPTF
Rc, W

BSW, BSF

Pg

EG (STI)
SELF-LOCK

Tr

Zubehör
Accessories

Tech. Info

BGF

ZBGF

GSF

GF

GF-KEG

ZGF

ZIRK-GF

Gigant

MoSys

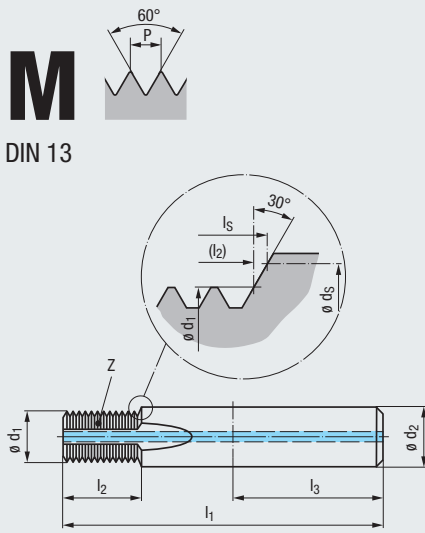

VHM

RH + LH

Z3 - Z4

DIN 6535
HB
HE
HA

120°

$\varnothing D$

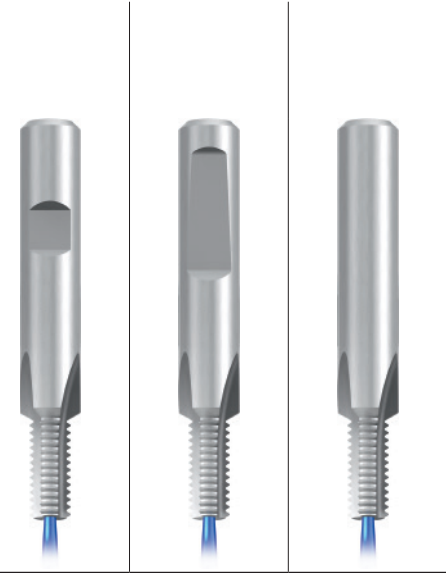

Einsatzgebiete – Material
Applications – material » 328

P 1.1-5.1 K 1.1-4.2 N 1.1-5, 2.1-6
N 3.1-2 N 4.1-2, 5.2 S 1.1-3

Gewindetiefe
Thread depth

1,5 x D

Werkzeug-Ident · Tool ident											Dimens.-Ident		
$\varnothing D$ mm	P mm	l_1	l_2	l_3	$\varnothing d_1$	$\varnothing d_2$	$\varnothing d_s$	l_s	Z				
M 3	0,5	42	4,7	28	2,4	4	3,3	5	3	.0030	GF323101	GF323401	GF323701
4	0,7	55	5,9	36	3,15	6	4,3	6,3	3	.0040	●	●	●
5	0,8	55	7,6	36	4	6	5,3	7,9	3	.0050	●	●	●
6	1	62	9,5	36	4,8	8	6,3	9,9	3	.0060	●	●	●
8	1,25	74	13,1	40	6,5	10	8,3	13,6	3	.0080	●	●	●
10	1,5	80	15,7	45	8,2	12	10,3	16,3	3	.0100	●	●	●
12	1,75	90	18,3	45	9,9	14	12,3	19	4	.0112	●	●	●
14	2	100	23	48	11,6	16	14,3	23,7	4	.0114	●	●	●
16	2	102	25	48	13,6	18	16,3	25,7	4	.0116	●	●	●

GF323101	GF323401	GF323701
GSF-VHM 1,5xD IKZ-HB	GSF-VHM 1,5xD IKZ-HE	GSF-VHM 1,5xD IKZ-HA
		● ¹⁾
●	●	●
●	●	●
●	●	●
●	●	●
●	●	●
●	●	●
●	●	●
●	●	●

Gewindetiefe
Thread depth

2 x D

Werkzeug-Ident · Tool ident											Dimens.-Ident		
$\varnothing D$ mm	P mm	l_1	l_2	l_3	$\varnothing d_1$	$\varnothing d_2$	$\varnothing d_s$	l_s	Z				
M 3	0,5	42	6,2	28	2,4	4	3,3	6,5	3	.0030	GF333101	GF333401	GF333701
4	0,7	55	8,7	36	3,15	6	4,3	9,1	3	.0040	●	●	●
5	0,8	55	10,8	36	4	6	5,3	11,1	3	.0050	●	●	●
6	1	62	12,5	36	4,8	8	6,3	12,9	3	.0060	●	●	●
8	1,25	74	16,8	40	6,5	10	8,3	17,4	3	.0080	●	●	●
10	1,5	80	20,2	45	8,2	12	10,3	20,8	3	.0100	●	●	●
12	1,75	90	25,3	45	9,9	14	12,3	26	4	.0112	●	●	●
14	2	100	29	48	11,6	16	14,3	29,7	4	.0114	●	●	●
16	2	102	33	48	13,6	18	16,3	33,7	4	.0116	●	●	●

GF333101	GF333401	GF333701
GSF-VHM 2xD IKZ-HB	GSF-VHM 2xD IKZ-HE	GSF-VHM 2xD IKZ-HA
		● ²⁾
●	●	●
●	●	●
●	●	●
●	●	●
●	●	●
●	●	●
●	●	●
●	●	●

Andere Abmessungen auf Anfrage
Other sizes upon request

¹⁾ M3 ohne innere Kühlschmierstoff-Zufuhr IKZ! Werkzeug-Ident = GF303701
M3 without internal coolant supply IKZ! Tool ident = GF303701

²⁾ M3 ohne innere Kühlschmierstoff-Zufuhr IKZ! Werkzeug-Ident = GF313701
M3 without internal coolant supply IKZ! Tool ident = GF313701

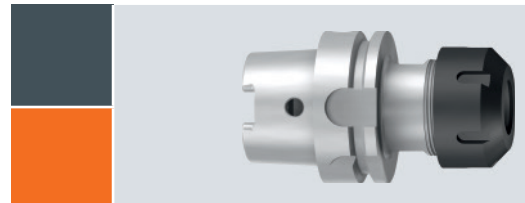

Spannzangen-Aufnahmen
Typ KSN/Synchro
siehe Seite 711 - 713

Collet holders
type KSN/Synchro,
see page 711 - 713

M



DIN 13

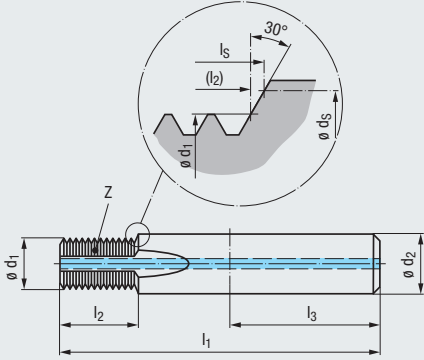

VHM	TICN
RH + LH	
Z3 - Z4	DIN 6535 HB HE HA
120°	θD

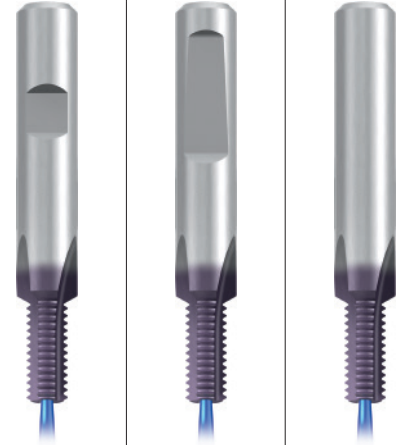

Einsatzgebiete – Material Applications – material 328

P 1.1-5.1 M 1.1-4.1 K 1.1-4.2
N 1.1-5.2 S 1.1-2.6 H 1.1-2

Gewindetiefe Thread depth

1,5 x D

Werkzeug-Ident · Tool ident

GF323106 GF323406 GF323706

θD mm	P mm	l_1	l_2	l_3	θd_1	θd_2	θd_3	l_s	Z	Dimens.- Ident	GF323106	GF323406	GF323706
											GSF-VHM 1,5xD IKZ-HB TICN	GSF-VHM 1,5xD IKZ-HE TICN	GSF-VHM 1,5xD IKZ-HA TICN
M 3	0,5	42	4,7	28	2,4	4	3,3	5	3	.0030			● ¹⁾
4	0,7	55	5,9	36	3,15	6	4,3	6,3	3	.0040	●	●	●
5	0,8	55	7,6	36	4	6	5,3	7,9	3	.0050	●	●	●
6	1	62	9,5	36	4,8	8	6,3	9,9	3	.0060	●	●	●
8	1,25	74	13,1	40	6,5	10	8,3	13,6	3	.0080	●	●	●
10	1,5	80	15,7	45	8,2	12	10,3	16,3	3	.0100	●	●	●
12	1,75	90	18,3	45	9,9	14	12,3	19	4	.0112	●	●	●
14	2	100	23	48	11,6	16	14,3	23,7	4	.0114	●	●	●
16	2	102	25	48	13,6	18	16,3	25,7	4	.0116	●	●	●

Gewindetiefe Thread depth

2 x D

Werkzeug-Ident · Tool ident

GF333106 GF333406 GF333706

θD mm	P mm	l_1	l_2	l_3	θd_1	θd_2	θd_3	l_s	Z	Dimens.- Ident	GF333106	GF333406	GF333706
											GSF-VHM 2xD IKZ-HB TICN	GSF-VHM 2xD IKZ-HE TICN	GSF-VHM 2xD IKZ-HA TICN
M 3	0,5	42	6,2	28	2,4	4	3,3	6,5	3	.0030			● ²⁾
4	0,7	55	8,7	36	3,15	6	4,3	9,1	3	.0040	●	●	●
5	0,8	55	10,8	36	4	6	5,3	11,1	3	.0050	●	●	●
6	1	62	12,5	36	4,8	8	6,3	12,9	3	.0060	●	●	●
8	1,25	74	16,8	40	6,5	10	8,3	17,4	3	.0080	●	●	●
10	1,5	80	20,2	45	8,2	12	10,3	20,8	3	.0100	●	●	●
12	1,75	90	25,3	45	9,9	14	12,3	26	4	.0112	●	●	●
14	2	100	29	48	11,6	16	14,3	29,7	4	.0114	●	●	●
16	2	102	33	48	13,6	18	16,3	33,7	4	.0116	●	●	●

Andere Abmessungen auf Anfrage Other sizes upon request

1) M3 ohne innere Kühlschmierstoff-Zufuhr IKZ! Werkzeug-Ident = GF303706
M3 without internal coolant supply IKZ! Tool ident = GF303706
2) M3 ohne innere Kühlschmierstoff-Zufuhr IKZ! Werkzeug-Ident = GF313706
M3 without internal coolant supply IKZ! Tool ident = GF313706

Product Finder

v_c / f_z

M

MF

UNC
UN, UNS

UNF
UNEF

G, Rp

NPT, NPTF
Rc, W

BSW, BSF

Pg

EG (STI)
SELF-LOCK

Tr

Zubehör
Accessories

Tech. Info

BGF

ZBGF

GSF

GF

GF-KEG

ZGF

ZIRK-GF

Gigant

MoSys

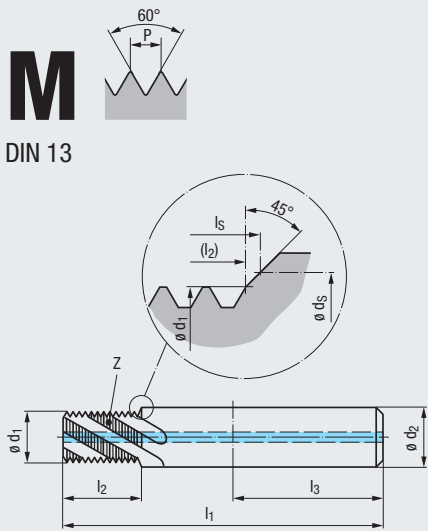

VHM

R30

RH + LH

Z3 - Z4

DIN 6535

HB
HE
HA

90°

$\varnothing D$

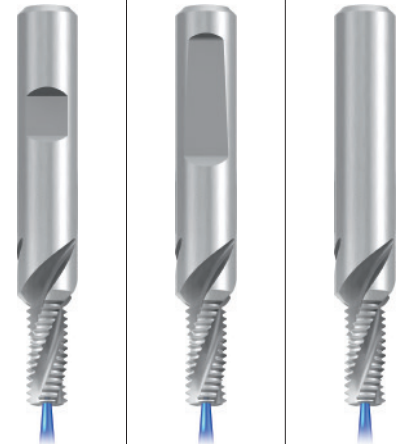

Einsatzgebiete – Material
Applications – material ▶ 328

P 1.1-3.1 K 1.1-4.2 N 1.1-5
N 2.1-6 N 3.1-4.2, 5.2 S 1.1-2

Gewindetiefe
Thread depth

1,5 x D

Werkzeug-Ident · Tool ident

	GF322101	GF322401	GF322701
	GSF-VHM 1,5xD R30-IKZ-HB	GSF-VHM 1,5xD R30-IKZ-HE	GSF-VHM 1,5xD R30-IKZ-HA
•	•	•	•
•	•	•	•
•	•	•	•
•	•	•	•
•	•	•	•
•	•	•	•
•	•	•	•

$\varnothing D$ mm	P mm	l_1	l_2	l_3	$\varnothing d_1$	$\varnothing d_2$	$\varnothing d_s$	l_s	Z	Dimens.- Ident
M 5	0,8	55	7,6	36	4	6	5,3	8,2	3	.0050
6	1	62	9,5	36	4,8	8	6,3	10,2	3	.0060
8	1,25	74	13,1	40	6,5	10	8,3	13,9	3	.0080
10	1,5	80	15,8	45	8,2	12	10,3	16,7	3	.0100
12	1,75	90	18,4	45	9,9	14	12,3	19,5	4	.0112
14	2	100	23	48	11,6	16	14,3	24,2	4	.0114
16	2	102	25	48	13,6	18	16,3	26,2	4	.0116

Gewindetiefe
Thread depth

2 x D

Werkzeug-Ident · Tool ident

	GF332101	GF332401	GF332701
	GSF-VHM 2xD R30-IKZ-HB	GSF-VHM 2xD R30-IKZ-HE	GSF-VHM 2xD R30-IKZ-HA
•	•	•	•
•	•	•	•
•	•	•	•
•	•	•	•
•	•	•	•
•	•	•	•
•	•	•	•

$\varnothing D$ mm	P mm	l_1	l_2	l_3	$\varnothing d_1$	$\varnothing d_2$	$\varnothing d_s$	l_s	Z	Dimens.- Ident
M 5	0,8	55	10,8	36	4	6	5,3	11,4	3	.0050
6	1	62	12,5	36	4,8	8	6,3	13,2	3	.0060
8	1,25	74	16,9	40	6,5	10	8,3	17,7	3	.0080
10	1,5	80	20,3	45	8,2	12	10,3	21,2	3	.0100
12	1,75	90	25,4	45	9,9	14	12,3	26,5	4	.0112
14	2	100	29	48	11,6	16	14,3	30,2	4	.0114
16	2	102	33	48	13,6	18	16,3	34,2	4	.0116

Gewindetiefe
Thread depth

2,5 x D

Werkzeug-Ident · Tool ident

	GF342101	GF342401	GF342701
	GSF-VHM 2,5xD R30-IKZ-HB	GSF-VHM 2,5xD R30-IKZ-HE	GSF-VHM 2,5xD R30-IKZ-HA
•	•	•	•
•	•	•	•
•	•	•	•
•	•	•	•
•	•	•	•
•	•	•	•
•	•	•	•

$\varnothing D$ mm	P mm	l_1	l_2	l_3	$\varnothing d_1$	$\varnothing d_2$	$\varnothing d_s$	l_s	Z	Dimens.- Ident
M 5	0,8	58	13,2	36	4	6	5,3	13,8	3	.0050
6	1	65	15,5	36	4,8	8	6,3	16,2	3	.0060
8	1,25	78	20,6	40	6,5	10	8,3	21,4	3	.0080
10	1,5	85	26,3	45	8,2	12	10,3	27,2	3	.0100
12	1,75	95	30,7	45	9,9	14	12,3	31,7	4	.0112
14	2	110	37	48	11,6	16	14,3	38,2	4	.0114
16	2	110	41	48	13,6	18	16,3	42,2	4	.0116

Andere Abmessungen auf Anfrage
Other sizes upon request

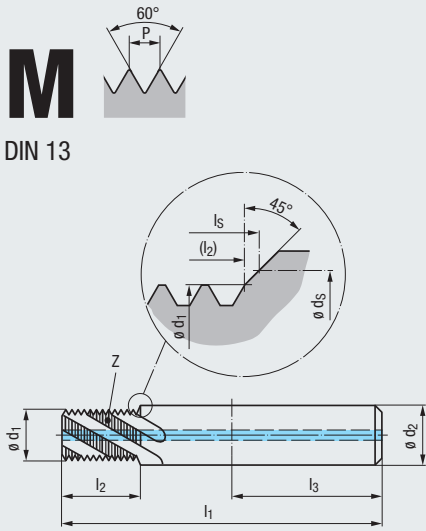

DIN 13

VHM	TICN
R30	RH + LH
Z3 - Z4	DIN 6535 HB HE HA
90°	θD

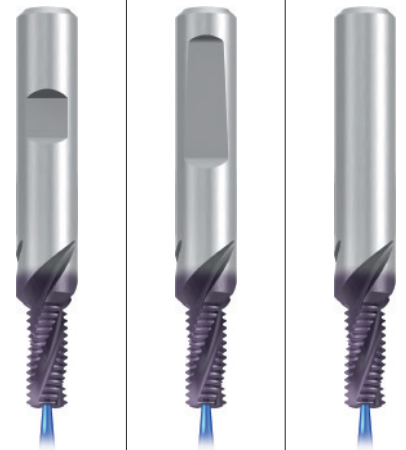

- Product Finder
- v_c / f_z
- M
- MF
- UNC
UN, UNS
- UNF
UNEF
- G, Rp
- NPT, NPTF
Rc, W
- BSW, BSF
- Pg
- EG (STI)
SELF-LOCK
- Tr

Einsatzgebiete – Material Applications – material ▶▶ 328

P 1.1-3.1	M 1.1-2.1	K 1.1-4.2
N 1.1-2.7	N 3.1-5.2	S 1.1-2, 2.1

Gewindetiefe Thread depth

1,5 x D

Werkzeug-Ident · Tool ident											GF322106	GF322406	GF322706
θD mm	P mm	l_1	l_2	l_3	θd_1	θd_2	θd_s	l_s	Z	Dimens.-Ident	GSF-VHM 1,5xD R30-1KZ-HB TICN	GSF-VHM 1,5xD R30-1KZ-HE TICN	GSF-VHM 1,5xD R30-1KZ-HA TICN
M 5	0,8	55	7,6	36	4	6	5,3	8,2	3	.0050	●	●	●
6	1	62	9,5	36	4,8	8	6,3	10,2	3	.0060	●	●	●
8	1,25	74	13,1	40	6,5	10	8,3	13,9	3	.0080	●	●	●
10	1,5	80	15,8	45	8,2	12	10,3	16,7	3	.0100	●	●	●
12	1,75	90	18,4	45	9,9	14	12,3	19,5	4	.0112	●	●	●
14	2	100	23	48	11,6	16	14,3	24,2	4	.0114	●	●	●
16	2	102	25	48	13,6	18	16,3	26,2	4	.0116	●	●	●

Gewindetiefe Thread depth

2 x D

Werkzeug-Ident · Tool ident											GF332106	GF332406	GF332706
θD mm	P mm	l_1	l_2	l_3	θd_1	θd_2	θd_s	l_s	Z	Dimens.-Ident	GSF-VHM 2xD R30-1KZ-HB TICN	GSF-VHM 2xD R30-1KZ-HE TICN	GSF-VHM 2xD R30-1KZ-HA TICN
M 5	0,8	55	10,8	36	4	6	5,3	11,4	3	.0050	●	●	●
6	1	62	12,5	36	4,8	8	6,3	13,2	3	.0060	●	●	●
8	1,25	74	16,9	40	6,5	10	8,3	17,7	3	.0080	●	●	●
10	1,5	80	20,3	45	8,2	12	10,3	21,2	3	.0100	●	●	●
12	1,75	90	25,4	45	9,9	14	12,3	26,5	4	.0112	●	●	●
14	2	100	29	48	11,6	16	14,3	30,2	4	.0114	●	●	●
16	2	102	33	48	13,6	18	16,3	34,2	4	.0116	●	●	●

Gewindetiefe Thread depth

2,5 x D

Werkzeug-Ident · Tool ident											GF342106	GF342406	GF342706
θD mm	P mm	l_1	l_2	l_3	θd_1	θd_2	θd_s	l_s	Z	Dimens.-Ident	GSF-VHM 2,5xD R30-1KZ-HB TICN	GSF-VHM 2,5xD R30-1KZ-HE TICN	GSF-VHM 2,5xD R30-1KZ-HA TICN
M 5	0,8	58	13,2	36	4	6	5,3	13,8	3	.0050	●	●	●
6	1	65	15,5	36	4,8	8	6,3	16,2	3	.0060	●	●	●
8	1,25	78	20,6	40	6,5	10	8,3	21,4	3	.0080	●	●	●
10	1,5	85	26,3	45	8,2	12	10,3	27,2	3	.0100	●	●	●
12	1,75	95	30,7	45	9,9	14	12,3	31,7	4	.0112	●	●	●
14	2	110	37	48	11,6	16	14,3	38,2	4	.0114	●	●	●
16	2	110	41	48	13,6	18	16,3	42,2	4	.0116	●	●	●

Andere Abmessungen auf Anfrage Other sizes upon request

- Zubehör Accessories
- Tech. Info
- BGF
- ZBGF
- GSF
- GF
- GF-KEG
- ZGF
- ZIRK-GF
- Gigant
- MoSys



● = Lagerwerkzeug, siehe Preisliste · Stock tool, see price list
○ = Kurzfristig lieferbar, Preis auf Anfrage · Available on short notice, price upon inquiry

- Product Finder
- v_c / f_z
- M
- MF
- UNC UN, UNS
- UNF UNEF
- G, Rp
- NPT, NPTF Rc, W
- BSW, BSF
- Pg
- EG (STI) SELF-LOCK
- Tr
- Zubehör Accessories
- Tech. Info
- BGF
- ZBGF
- GSF
- GF
- GF-KEG
- ZGF
- ZIRK-GF
- Gigant
- MoSys

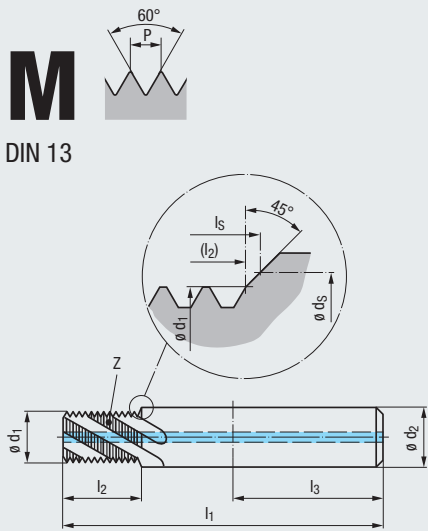

VHM

R15 RH + LH

Z4 - Z5 **DIN 6535**
HB HE HA

90° $\varnothing D$

Mit höherer Nutenzahl
With increased number of flutes

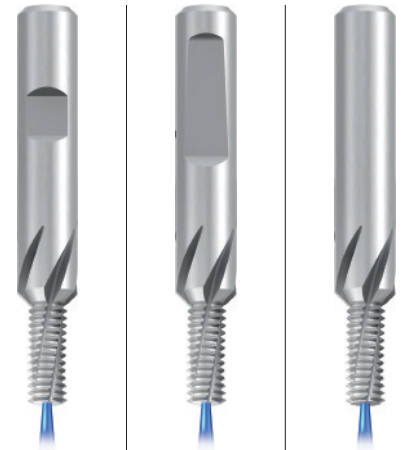

Einsatzgebiete – Material Applications – material » 328

P	1.1-5.1	K	1.1-4.2	N	1.1-5, 2.1-6
N	3.1-2	N	4.1-2, 5.2	S	1.1-3

Gewindetiefe Thread depth

2 x D

Werkzeug-Ident · Tool ident

	GF335121	GF335421	GF335721
GSF-Z-VHM 2xD R15- IKZ-HB	●	●	●
GSF-Z-VHM 2xD R15- IKZ-HE	●	●	●
GSF-Z-VHM 2xD R15- IKZ-HA	●	●	●

	$\varnothing D$ mm	P mm	l_1	l_2	l_3	$\varnothing d_1$	$\varnothing d_2$	$\varnothing d_s$	l_s	Z	Dimens.- Ident	Werkzeug-Ident · Tool ident		
												GF335121	GF335421	GF335721
M	6	1	62	12,5	36	4,8	8	6,3	13,2	4	.0060	●	●	●
	8	1,25	74	16,9	40	6,5	10	8,3	17,7	4	.0080	●	●	●
	10	1,5	80	20,3	45	8,2	12	10,3	21,2	5	.0100	●	●	●
	12	1,75	90	25,4	45	9,9	14	12,3	26,5	5	.0112	●	●	●

Andere Abmessungen auf Anfrage
Other sizes upon request

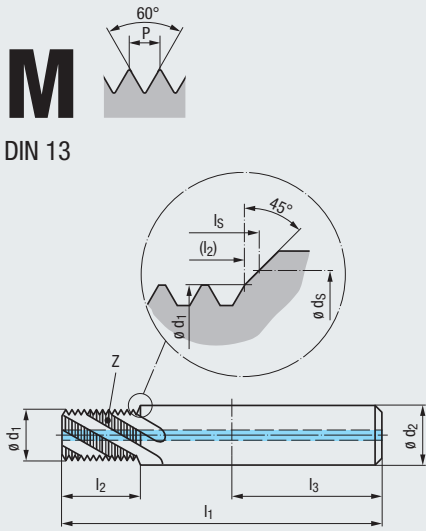

Einsatzgebiete – Material Applications – material ▶▶ 328

Gewindetiefe Thread depth

Werkzeug-Ident · Tool ident

	θD mm	P mm	l_1	l_2	l_3	θd_1	θd_2	θd_3	l_s	Z	Dimens.- Ident
M	6	1	62	12,5	36	4,8	8	6,3	13,2	4	.0060
	8	1,25	74	16,9	40	6,5	10	8,3	17,7	4	.0080
	10	1,5	80	20,3	45	8,2	12	10,3	21,2	5	.0100
	12	1,75	90	25,4	45	9,9	14	12,3	26,5	5	.0112

Andere Abmessungen auf Anfrage
Other sizes upon request

VHM	TICN
R15	RH + LH
Z4 - Z5	DIN 6535 HB HE HA
90°	θD

Mit höherer Nutenzahl
With increased number of flutes

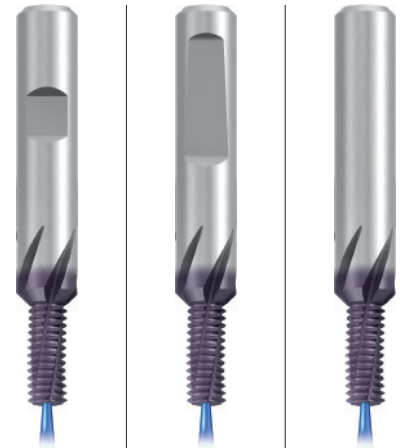

P 1.1-5.1 M 1.1-4.1 K 1.1-4.2
N 1.1-5.2 S 1.1-2.6 H 1.1-2

2 x D

	GF335126	GF335426	GF335726
GSF-Z-VHM 2xD R15-1KZ-HB TICN	●	●	●
GSF-Z-VHM 2xD R15-1KZ-HE TICN	●	●	●
GSF-Z-VHM 2xD R15-1KZ-HA TICN	●	●	●

Product Finder

v_c / f_z

M

MF

UNC
UN, UNS

UNF
UNEF

G, Rp

NPT, NPTF
Rc, W

BSW, BSF

Pg

EG (STI)
SELF-LOCK

Tr

Zubehör
Accessories

Tech. Info

BGF

ZBGF

GSF

GF

GF-KEG

ZGF

ZIRK-GF

Gigant

MoSys

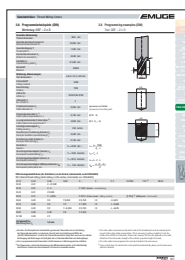

Programmierbeispiel für Gewindefräser mit Senkfase Typ GSF siehe Seite 465

Programming example for thread milling cutters with countersinking step type GSF, see page 465

- Product Finder
- v_c / f_z
- M
- MF
- UNC
UN, UNS
- UNF
UNEF
- G, Rp
- NPT, NPTF
Rc, W
- BSW, BSF
- Pg
- EG (STI)
SELF-LOCK
- Tr
- Zubehör
Accessories
- Tech. Info
- BGF
- ZBGF
- GSF
- GF
- GF-KEG
- ZGF
- ZIRK-GF
- Gigant
- MoSys

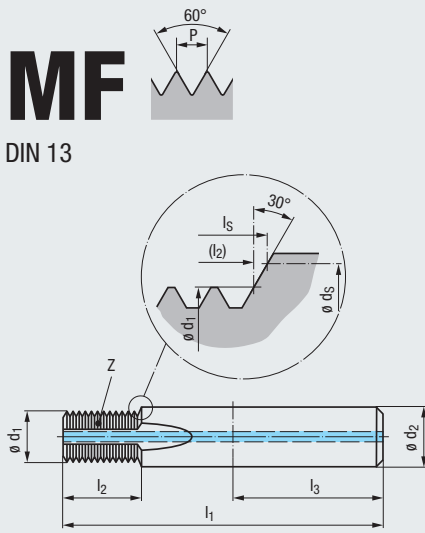

VHM

RH + LH

Z3 - Z4

DIN 6535
HB
HE
HA

120°

$\varnothing D$

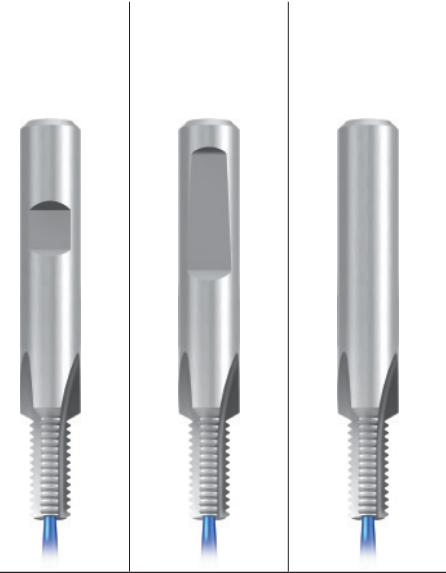

Einsatzgebiete – Material Applications – material ▶▶ 328

P 1.1-5.1 **K** 1.1-4.2 **N** 1.1-5, 2.1-6
N 3.1-2 **N** 4.1-2, 5.2 **S** 1.1-3

Gewindetiefe Thread depth

1,5 x D

Werkzeug-Ident · Tool ident											Dimens.-Ident	GF323101	GF323401	GF323701
$\varnothing D$ mm	P mm	l_1	l_2	l_3	$\varnothing d_1$	$\varnothing d_2$	$\varnothing d_3$	l_s	Z			GSF-VHM 1,5xD IKZ-HB	GSF-VHM 1,5xD IKZ-HE	GSF-VHM 1,5xD IKZ-HA
M 6 x 0,75	62	9,4	36	5	8	6,3	9,7	3	.0229	●	●	●		
8 x 1	74	12,5	40	6,7	10	8,3	12,9	3	.0251	●	●	●		
10 x 1	80	15,5	45	8,7	12	10,3	15,9	3	.0276	●	●	●		
10 x 1,25	80	15,6	45	8,4	12	10,3	16,1	3	.0277	●	●	●		
12 x 1	90	18,5	45	10,6	14	12,3	19	4	.0301	●	●	●		
12 x 1,25	90	18,1	45	10,4	14	12,3	18,6	4	.0302	●	●	●		
12 x 1,5	90	18,7	45	10,1	14	12,3	19,3	4	.0303	●	●	●		
14 x 1,5	100	21,7	48	12,1	16	14,3	22,3	4	.0331	●	●	●		
16 x 1,5	102	24,7	48	14	18	16,3	25,4	4	.0359	●	●	●		

Gewindetiefe Thread depth

2 x D

Werkzeug-Ident · Tool ident											Dimens.-Ident	GF333101	GF333401	GF333701
$\varnothing D$ mm	P mm	l_1	l_2	l_3	$\varnothing d_1$	$\varnothing d_2$	$\varnothing d_3$	l_s	Z			GSF-VHM 2xD IKZ-HB	GSF-VHM 2xD IKZ-HE	GSF-VHM 2xD IKZ-HA
M 6 x 0,75	62	12,4	36	5	8	6,3	12,7	3	.0229	●	●	●		
8 x 1	74	16,5	40	6,7	10	8,3	16,9	3	.0251	●	●	●		
10 x 1	80	20,5	45	8,7	12	10,3	20,9	3	.0276	●	●	●		
10 x 1,25	80	20,6	45	8,4	12	10,3	21,1	3	.0277	●	●	●		
12 x 1	90	24,5	45	10,6	14	12,3	25	4	.0301	●	●	●		
12 x 1,25	90	24,3	45	10,4	14	12,3	24,9	4	.0302	●	●	●		
12 x 1,5	90	24,7	45	10,1	14	12,3	25,3	4	.0303	●	●	●		
14 x 1,5	100	29,2	48	12,1	16	14,3	29,8	4	.0331	●	●	●		
16 x 1,5	102	32,2	48	14	18	16,3	32,9	4	.0359	●	●	●		

Andere Abmessungen auf Anfrage
Other sizes upon request

MF



DIN 13

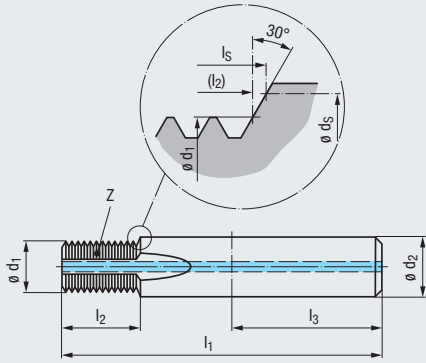

VHM **TICN**

RH + LH

Z3 - Z4 **DIN 6535**
 HB
 HE
 HA

120° **θD**

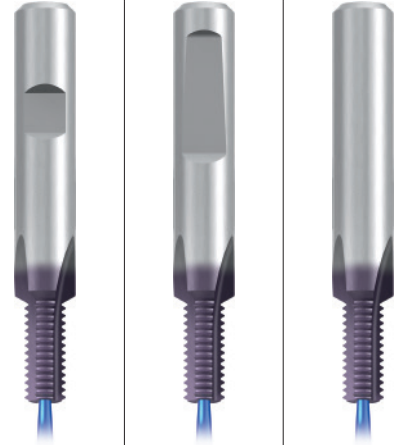

Einsatzgebiete – Material Applications – material 328

P 1.1-5.1 **M** 1.1-4.1 **K** 1.1-4.2
N 1.1-5.2 **S** 1.1-2.6 **H** 1.1-2

Gewindetiefe Thread depth

1,5 x D

Werkzeug-Ident · Tool ident

GF323106 GF323406 GF323706

θD mm	P mm	l_1	l_2	l_3	θd_1	θd_2	θd_3	l_s	Z	Dimens.- Ident	GSF-VHM	GSF-VHM	GSF-VHM
											1,5xD IKZ-HB TICN	1,5xD IKZ-HE TICN	1,5xD IKZ-HA TICN
M 6 x 0,75	62	9,4	36	5	8	6,3	9,7	3	.0229	●	●	●	
8 x 1	74	12,5	40	6,7	10	8,3	12,9	3	.0251	●	●	●	
10 x 1	80	15,5	45	8,7	12	10,3	15,9	3	.0276	●	●	●	
10 x 1,25	80	15,6	45	8,4	12	10,3	16,1	3	.0277	●	●	●	
12 x 1	90	18,5	45	10,6	14	12,3	19	4	.0301	●	●	●	
12 x 1,25	90	18,1	45	10,4	14	12,3	18,6	4	.0302	●	●	●	
12 x 1,5	90	18,7	45	10,1	14	12,3	19,3	4	.0303	●	●	●	
14 x 1,5	100	21,7	48	12,1	16	14,3	22,3	4	.0331	●	●	●	
16 x 1,5	102	24,7	48	14	18	16,3	25,4	4	.0359	●	●	●	

Gewindetiefe Thread depth

2 x D

Werkzeug-Ident · Tool ident

GF333106 GF333406 GF333706

θD mm	P mm	l_1	l_2	l_3	θd_1	θd_2	θd_3	l_s	Z	Dimens.- Ident	GSF-VHM	GSF-VHM	GSF-VHM
											2xD IKZ-HB TICN	2xD IKZ-HE TICN	2xD IKZ-HA TICN
M 6 x 0,75	62	12,4	36	5	8	6,3	12,7	3	.0229	●	●	●	
8 x 1	74	16,5	40	6,7	10	8,3	16,9	3	.0251	●	●	●	
10 x 1	80	20,5	45	8,7	12	10,3	20,9	3	.0276	●	●	●	
10 x 1,25	80	20,6	45	8,4	12	10,3	21,1	3	.0277	●	●	●	
12 x 1	90	24,5	45	10,6	14	12,3	25	4	.0301	●	●	●	
12 x 1,25	90	24,3	45	10,4	14	12,3	24,9	4	.0302	●	●	●	
12 x 1,5	90	24,7	45	10,1	14	12,3	25,3	4	.0303	●	●	●	
14 x 1,5	100	29,2	48	12,1	16	14,3	29,8	4	.0331	●	●	●	
16 x 1,5	102	32,2	48	14	18	16,3	32,9	4	.0359	●	●	●	

Andere Abmessungen auf Anfrage
 Other sizes upon request

Product Finder

v_c / f_z

M

MF

UNC UN, UNS

UNF UNEF

G, Rp

NPT, NPTF Rc, W

BSW, BSF

Pg

EG (STI) SELF-LOCK

Tr

Zubehör Accessories

Tech. Info

BGF

ZBGF

GSF

GF

GF-KEG

ZGF

ZIRK-GF

Gigant

MoSys

Product Finder

v_c / f_z

M

MF

UNC
UN, UNS

UNF
UNEF

G, Rp

NPT, NPTF
Rc, W

BSW, BSF

Pg

EG (STI)
SELF-LOCK

Tr

Zubehör
Accessories

Tech. Info

BGF

ZBGF

GSF

GF

GF-KEG

ZGF

ZIRK-GF

Gigant

MoSys

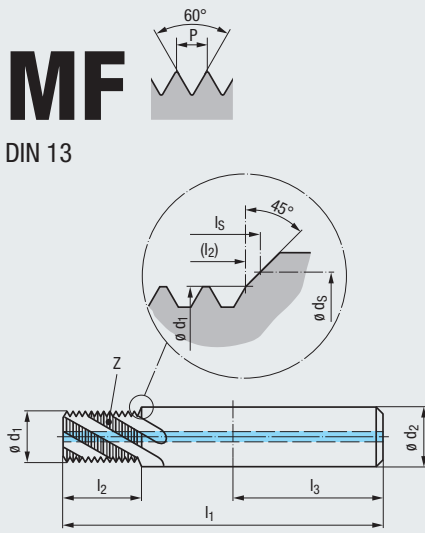
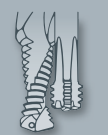

VHM

R30 RH + LH

Z3 - Z4
DIN 6535
HB
HE
HA

90° $\varnothing D$

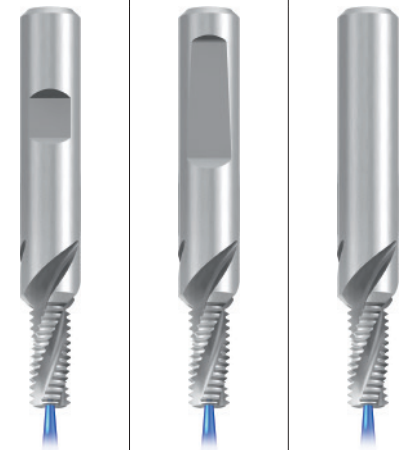

Einsatzgebiete – Material Applications – material **328**

P 1.1-3.1 K 1.1-4.2 N 1.1-5
N 2.1-6 N 3.1-4.2, 5.2 S 1.1-2

Gewindetiefe Thread depth

1,5 x D

Werkzeug-Ident · Tool ident

	GF322101	GF322401	GF322701
GSF-VHM 1,5xD R30-IKZ-HB	●	●	●
GSF-VHM 1,5xD R30-IKZ-HE	●	●	●
GSF-VHM 1,5xD R30-IKZ-HA	●	●	●

$\varnothing D$ mm	P mm	l_1	l_2	l_3	$\varnothing d_1$	$\varnothing d_2$	$\varnothing d_s$	l_s	Z	Dimens.-Ident
M 6 x 0,75	62	9,4	36	5	8	6,3	10	3	.0229	
8 x 1	74	12,5	40	6,7	10	8,3	13,2	3	.0251	
10 x 1	80	15,5	45	8,7	12	10,3	16,2	3	.0276	
10 x 1,25	80	15,7	45	8,4	12	10,3	16,5	3	.0277	
12 x 1	90	18,5	45	10,6	14	12,3	19,3	4	.0301	
12 x 1,25	90	18,2	45	10,4	14	12,3	19	4	.0302	
12 x 1,5	90	18,8	45	10,1	14	12,3	19,7	4	.0303	
14 x 1,5	100	21,8	48	12,1	16	14,3	22,7	4	.0331	
16 x 1,5	102	24,8	48	14	18	16,3	25,8	4	.0359	

Gewindetiefe Thread depth

2 x D

Werkzeug-Ident · Tool ident

	GF332101	GF332401	GF332701
GSF-VHM 2xD R30-IKZ-HB	●	●	●
GSF-VHM 2xD R30-IKZ-HE	●	●	●
GSF-VHM 2xD R30-IKZ-HA	●	●	●

$\varnothing D$ mm	P mm	l_1	l_2	l_3	$\varnothing d_1$	$\varnothing d_2$	$\varnothing d_s$	l_s	Z	Dimens.-Ident
M 6 x 0,75	62	12,4	36	5	8	6,3	13	3	.0229	
8 x 1	74	16,5	40	6,7	10	8,3	17,2	3	.0251	
10 x 1	80	20,5	45	8,7	12	10,3	21,2	3	.0276	
10 x 1,25	80	20,7	45	8,4	12	10,3	21,5	3	.0277	
12 x 1	90	24,5	45	10,6	14	12,3	25,3	4	.0301	
12 x 1,25	90	24,4	45	10,4	14	12,3	25,2	4	.0302	
12 x 1,5	90	24,8	45	10,1	14	12,3	25,7	4	.0303	
14 x 1,5	100	29,3	48	12,1	16	14,3	30,2	4	.0331	
16 x 1,5	102	32,3	48	14	18	16,3	33,3	4	.0359	

Andere Abmessungen auf Anfrage
Other sizes upon request

MF

DIN 13

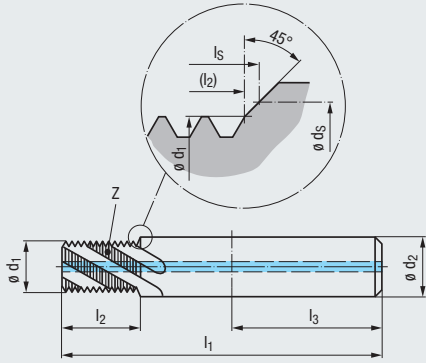
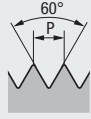

VHM	TICN
R30	RH + LH
Z3 - Z4	DIN 6535 HB HE HA
90°	θD

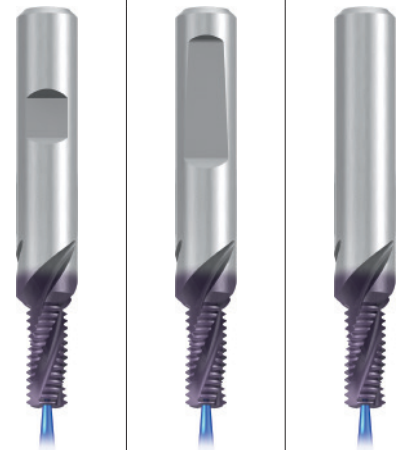

Einsatzgebiete – Material Applications – material **328**

P 1.1-3.1	M 1.1-2.1	K 1.1-4.2
N 1.1-2.7	N 3.1-5.2	S 1.1-2.2.1

Gewindetiefe Thread depth

1,5 x D

Werkzeug-Ident · Tool ident

GF322106 GF322406 GF322706

θD mm	P mm	l_1	l_2	l_3	θd_1	θd_2	θd_s	l_s	Z	Dimens.- Ident	GF322106	GF322406	GF322706
											GSF-VHM 1,5xD R30-1KZ-HB TICN	GSF-VHM 1,5xD R30-1KZ-HE TICN	GSF-VHM 1,5xD R30-1KZ-HA TICN
M 6 x 0,75	62	9,4	36	5	8	6,3	10	3	.0229	●	●	●	
8 x 1	74	12,5	40	6,7	10	8,3	13,2	3	.0251	●	●	●	
10 x 1	80	15,5	45	8,7	12	10,3	16,2	3	.0276	●	●	●	
10 x 1,25	80	15,7	45	8,4	12	10,3	16,5	3	.0277	●	●	●	
12 x 1	90	18,5	45	10,6	14	12,3	19,3	4	.0301	●	●	●	
12 x 1,25	90	18,2	45	10,4	14	12,3	19	4	.0302	●	●	●	
12 x 1,5	90	18,8	45	10,1	14	12,3	19,7	4	.0303	●	●	●	
14 x 1,5	100	21,8	48	12,1	16	14,3	22,7	4	.0331	●	●	●	
16 x 1,5	102	24,8	48	14	18	16,3	25,8	4	.0359	●	●	●	

Gewindetiefe Thread depth

2 x D

Werkzeug-Ident · Tool ident

GF332106 GF332406 GF332706

θD mm	P mm	l_1	l_2	l_3	θd_1	θd_2	θd_s	l_s	Z	Dimens.- Ident	GF332106	GF332406	GF332706
											GSF-VHM 2xD R30-1KZ-HB TICN	GSF-VHM 2xD R30-1KZ-HE TICN	GSF-VHM 2xD R30-1KZ-HA TICN
M 6 x 0,75	62	12,4	36	5	8	6,3	13	3	.0229	●	●	●	
8 x 1	74	16,5	40	6,7	10	8,3	17,2	3	.0251	●	●	●	
10 x 1	80	20,5	45	8,7	12	10,3	21,2	3	.0276	●	●	●	
10 x 1,25	80	20,7	45	8,4	12	10,3	21,5	3	.0277	●	●	●	
12 x 1	90	24,5	45	10,6	14	12,3	25,3	4	.0301	●	●	●	
12 x 1,25	90	24,4	45	10,4	14	12,3	25,2	4	.0302	●	●	●	
12 x 1,5	90	24,8	45	10,1	14	12,3	25,7	4	.0303	●	●	●	
14 x 1,5	100	29,3	48	12,1	16	14,3	30,2	4	.0331	●	●	●	
16 x 1,5	102	32,3	48	14	18	16,3	33,3	4	.0359	●	●	●	

Andere Abmessungen auf Anfrage
Other sizes upon request

Product Finder

v_c / f_z

M

MF

UNC
UN, UNS

UNF
UNEF

G, Rp

NPT, NPTF
Rc, W

BSW, BSF

Pg

EG (STI)
SELF-LOCK

Tr

Zubehör
Accessories

Tech. Info

BGF

ZBGF

GSF

GF

GF-KEG

ZGF

ZIRK-GF

Gigant

MoSys

- Product Finder
- v_c / f_z
- M
- MF**
- UNC
UN, UNS
- UNF
UNEF
- G, Rp
- NPT, NPTF
Rc, W
- BSW, BSF
- Pg
- EG (STI)
SELF-LOCK
- Tr
- Zubehör
Accessories
- Tech. Info
- BGF
- ZBGF
- GSF**
- GF
- GF-KEG
- ZGF
- ZIRK-GF
- Gigant
- MoSys

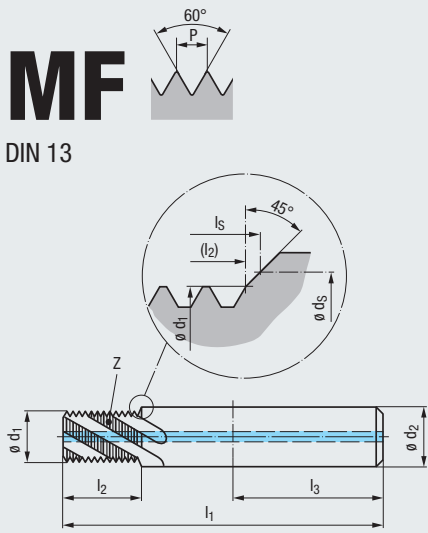

VHM

R15 **RH + LH**

Z4 - Z5 **DIN 6535**
 HB
 HE
 HA

90° $\varnothing D$

Mit höherer Nutenzahl
 With increased number of flutes

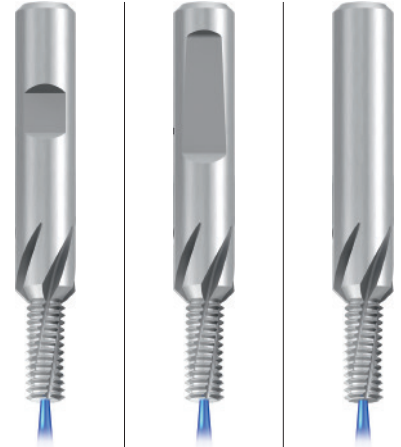

Einsatzgebiete – Material
 Applications – material **328**

P 1.1-5.1	K 1.1-4.2	N 1.1-5, 2.1-6
N 3.1-2	N 4.1-2, 5.2	S 1.1-3

Gewindetiefe
 Thread depth

2 x D

Werkzeug-Ident · Tool ident

	GF335121	GF335421	GF335721
GSF-Z-VHM 2xD R15-1KZ-HB	●	●	●
GSF-Z-VHM 2xD R15-1KZ-HE	●	●	●
GSF-Z-VHM 2xD R15-1KZ-HA	●	●	●

	$\varnothing D$ mm	P mm	l_1	l_2	l_3	$\varnothing d_1$	$\varnothing d_2$	$\varnothing d_s$	l_s	Z	Dimens.- Ident
M	8	x 1	74	16,5	40	6,7	10	8,3	17,2	4	.0251
	10	x 1	80	20,5	45	8,7	12	10,3	21,2	5	.0276
	12	x 1,25	90	24,4	45	10,4	14	12,3	25,2	5	.0302

Andere Abmessungen auf Anfrage
 Other sizes upon request

MF

DIN 13

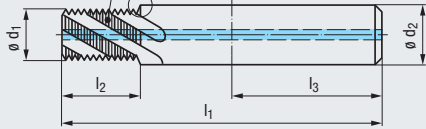
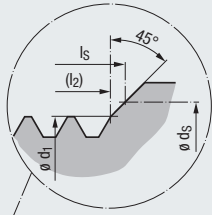

VHM	TICN
R15	RH + LH
Z4 - Z5	DIN 6535 HB HE HA
90°	Ø D

Mit höherer Nutenzahl
With increased number of flutes

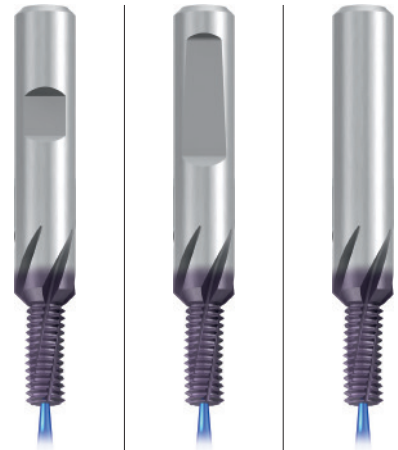

Einsatzgebiete – Material
Applications – material

» 328

P 1.1-5.1 M 1.1-4.1 K 1.1-4.2
N 1.1-5.2 S 1.1-2.6 H 1.1-2

Gewindetiefe
Thread depth

2 x D

Werkzeug-Ident · Tool ident

											Dimens.-Ident	GF335126	GF335426	GF335726
Ø D	P	l ₁	l ₂	l ₃	Ø d ₁	Ø d ₂	Ø d _s	l _s	Z		GSF-Z-VHM 2xD R15-1KZ-HB TICN	GSF-Z-VHM 2xD R15-1KZ-HE TICN	GSF-Z-VHM 2xD R15-1KZ-HA TICN	
M 8	x 1	74	16,5	40	6,7	10	8,3	17,2	4	.0251	●	●	●	
10	x 1	80	20,5	45	8,7	12	10,3	21,2	5	.0276	●	●	●	
12	x 1,25	90	24,4	45	10,4	14	12,3	25,2	5	.0302	●	●	●	

Andere Abmessungen auf Anfrage
Other sizes upon request

Product Finder

v_c / f_z

M

MF

UNC
UN, UNS

UNF
UNEF

G, Rp

NPT, NPTF
Rc, W

BSW, BSF

Pg

EG (STI)
SELF-LOCK

Tr

Zubehör
Accessories

Tech. Info

BGF

ZBGF

GSF

GF

GF-KEG

ZGF

ZIRK-GF

Gigant

MoSys

Product Finder

v_c / f_z

M

MF

UNC
UN, UNS

UNF
UNEF

G, Rp

NPT, NPTF
Rc, W

BSW, BSF

Pg

EG (STI)
SELF-LOCK

Tr

Zubehör
Accessories

Tech. Info

BGF

ZBGF

GSF

GF

GF-KEG

ZGF

ZIRK-GF

Gigant

MoSys

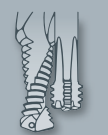

UNC

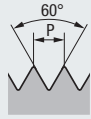

ASME B.1.1

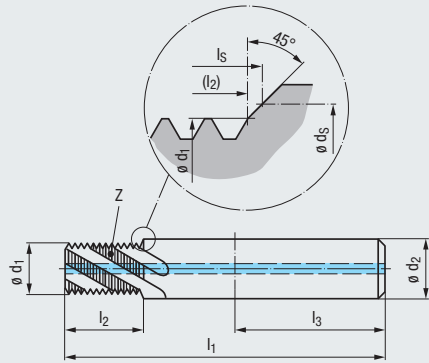

VHM

R30

RH + LH

Z3 - Z5



DIN 6535



Einsatzgebiete – Material
Applications – material

» 328

P 1.1-3.1 K 1.1-4.2 N 1.1-5
N 2.1-6 N 3.1-4.2, 5.2 S 1.1-2

Gewindetiefe
Thread depth

1,5 x D

Werkzeug-Ident · Tool ident

GF322101 GF322401 GF322701

θD inch	P Gg/1" (tpi)	l_1	l_2	l_3	θd_1	θd_2	θd_s	l_s	Z	Dimens.- Ident
Nr. 12	24	62	9	36	4,15	8	5,79	9,7	3	.5008
1/4	20	62	10,8	36	4,7	8	6,65	11,7	3	.5009
5/16	18	74	13,4	40	6,15	10	8,25	14,4	3	.5010
3/8	16	80	15,1	45	7,65	12	9,83	16,1	3	.5011
7/16	14	80	17,3	45	9	12	11,43	18,3	3	.5012
1/2	13	90	20,6	45	10,35	14	13	21,7	4	.5013
9/16	12	100	22,3	48	11,8	16	14,61	23,5	4	.5014
5/8	11	102	24,3	48	13,1	18	16,18	25,6	4	.5015
3/4	10	110	29,3	50	16	20	19,35	30,7	5	.5016

GSF-VHM 1,5xD R30-IKZ-HB	GSF-VHM 1,5xD R30-IKZ-HE	GSF-VHM 1,5xD R30-IKZ-HA
•	•	•
•	•	•
•	•	•
•	•	•
•	•	•
•	•	•
•	•	•
•	•	•
•	•	•
•	•	•

Gewindetiefe
Thread depth

2 x D

Werkzeug-Ident · Tool ident

GF332101 GF332401 GF332701

θD inch	P Gg/1" (tpi)	l_1	l_2	l_3	θd_1	θd_2	θd_s	l_s	Z	Dimens.- Ident
Nr. 12	24	62	11,1	36	4,15	8	5,79	11,9	3	.5008
1/4	20	62	13,3	36	4,7	8	6,65	14,2	3	.5009
5/16	18	74	16,2	40	6,15	10	8,25	17,2	3	.5010
3/8	16	80	19,9	45	7,65	12	9,83	20,8	3	.5011
7/16	14	80	22,7	45	9	12	11,43	23,8	3	.5012
1/2	13	90	26,4	45	10,35	14	13	27,6	4	.5013
9/16	12	100	30,7	48	11,8	16	14,61	32	4	.5014
5/8	11	102	33,5	48	13,1	18	16,18	34,9	4	.5015
3/4	10	110	39,4	50	16	20	19,35	40,9	5	.5016

GSF-VHM 2xD R30-IKZ-HB	GSF-VHM 2xD R30-IKZ-HE	GSF-VHM 2xD R30-IKZ-HA
•	•	•
•	•	•
•	•	•
•	•	•
•	•	•
•	•	•
•	•	•
•	•	•
•	•	•
•	•	•

Gewindetiefe
Thread depth

2,5 x D

Werkzeug-Ident · Tool ident

GF342101 GF342401 GF342701

θD inch	P Gg/1" (tpi)	l_1	l_2	l_3	θd_1	θd_2	θd_s	l_s	Z	Dimens.- Ident
3/8	16	85	24,6	45	7,65	12	9,83	25,6	3	.5011
7/16	14	85	28,2	45	9	12	11,43	29,2	3	.5012
1/2	13	96	32,3	45	10,35	14	13	33,4	4	.5013
9/16	12	107	37,1	48	11,8	16	14,61	38,3	4	.5014
5/8	11	110	40,5	48	13,1	18	16,18	41,8	4	.5015
3/4	10	125	49,6	50	16	20	19,35	51,1	5	.5016

GSF-VHM 2,5xD R30-IKZ-HB	GSF-VHM 2,5xD R30-IKZ-HE	GSF-VHM 2,5xD R30-IKZ-HA
•	•	•
•	•	•
•	•	•
•	•	•
•	•	•
•	•	•

Andere Abmessungen auf Anfrage
Other sizes upon request

UNC

ASME B.1.1

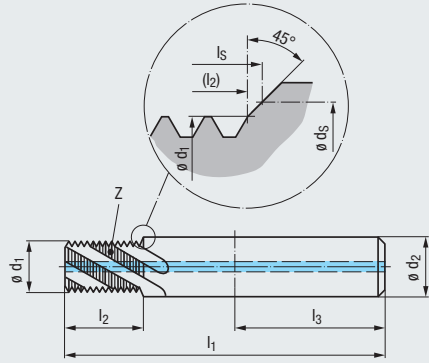

VHM	TICN
R30	RH + LH
Z3 - Z5	DIN 6535 HB HE HA
90°	θD

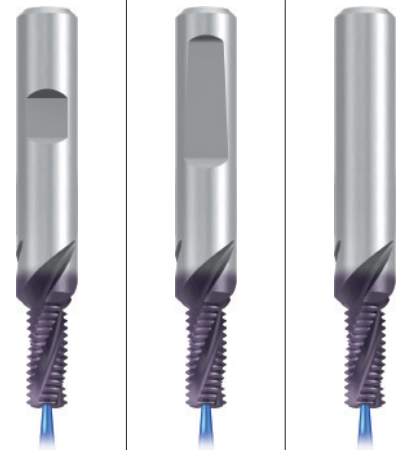

- Product Finder
- v_c / f_z
- M
- MF
- UNC
UN, UNS
- UNF
UNEF
- G, Rp
- NPT, NPTF
Rc, W
- BSW, BSF
- Pg
- EG (STI)
SELF-LOCK

Einsatzgebiete – Material Applications – material **328**

P 1.1-3.1	M 1.1-2.1	K 1.1-4.2
N 1.1-2.7	N 3.1-5.2	S 1.1-2, 2.1

Gewindetiefe Thread depth

1,5 x D

Werkzeug-Ident · Tool ident

θD inch	P Gg/1" (tpi)	l_1	l_2	l_3	θd_1	θd_2	θd_3	l_s	Z	Dimens.-Ident	GF322106	GF322406	GF322706
											GSF-VHM 1,5xD R30-IKZ-HB TICN	GSF-VHM 1,5xD R30-IKZ-HE TICN	GSF-VHM 1,5xD R30-IKZ-HA TICN
Nr. 12	24	62	9	36	4,15	8	5,79	9,7	3	.5008			
1/4	20	62	10,8	36	4,7	8	6,65	11,7	3	.5009	●	●	●
5/16	18	74	13,4	40	6,15	10	8,25	14,4	3	.5010	●	●	●
3/8	16	80	15,1	45	7,65	12	9,83	16,1	3	.5011	●	●	●
7/16	14	80	17,3	45	9	12	11,43	18,3	3	.5012	●	●	●
1/2	13	90	20,6	45	10,35	14	13	21,7	4	.5013	●	●	●
9/16	12	100	22,3	48	11,8	16	14,61	23,5	4	.5014	●	●	●
5/8	11	102	24,3	48	13,1	18	16,18	25,6	4	.5015	●	●	●
3/4	10	110	29,3	50	16	20	19,35	30,7	5	.5016	●	●	●

Gewindetiefe Thread depth

2 x D

Werkzeug-Ident · Tool ident

θD inch	P Gg/1" (tpi)	l_1	l_2	l_3	θd_1	θd_2	θd_3	l_s	Z	Dimens.-Ident	GF332106	GF332406	GF332706
											GSF-VHM 2xD R30-IKZ-HB TICN	GSF-VHM 2xD R30-IKZ-HE TICN	GSF-VHM 2xD R30-IKZ-HA TICN
Nr. 12	24	62	11,1	36	4,15	8	5,79	11,9	3	.5008			
1/4	20	62	13,3	36	4,7	8	6,65	14,2	3	.5009	●	●	●
5/16	18	74	16,2	40	6,15	10	8,25	17,2	3	.5010	●	●	●
3/8	16	80	19,9	45	7,65	12	9,83	20,8	3	.5011	●	●	●
7/16	14	80	22,7	45	9	12	11,43	23,8	3	.5012	●	●	●
1/2	13	90	26,4	45	10,35	14	13	27,6	4	.5013	●	●	●
9/16	12	100	30,7	48	11,8	16	14,61	32	4	.5014	●	●	●
5/8	11	102	33,5	48	13,1	18	16,18	34,9	4	.5015	●	●	●
3/4	10	110	39,4	50	16	20	19,35	40,9	5	.5016	●	●	●

Gewindetiefe Thread depth

2,5 x D

Werkzeug-Ident · Tool ident

θD mm	P Gg/1" (tpi)	l_1	l_2	l_3	θd_1	θd_2	θd_3	l_s	Z	Dimens.-Ident	GF342106	GF342406	GF342706
											GSF-VHM 2,5xD R30-IKZ-HB TICN	GSF-VHM 2,5xD R30-IKZ-HE TICN	GSF-VHM 2,5xD R30-IKZ-HA TICN
3/8	16	85	24,6	45	7,65	12	9,83	25,6	3	.5011	●	●	●
7/16	14	85	28,2	45	9	12	11,43	29,2	3	.5012	●	●	●
1/2	13	96	32,3	45	10,35	14	13	33,4	4	.5013	●	●	●
9/16	12	107	37,1	48	11,8	16	14,61	38,3	4	.5014	●	●	●
5/8	11	110	40,5	48	13,1	18	16,18	41,8	4	.5015	●	●	●
3/4	10	125	49,6	50	16	20	19,35	51,1	5	.5016	●	●	●

Andere Abmessungen auf Anfrage
Other sizes upon request

- Zubehör Accessories
- Tech. Info
- BGF
- ZBGF
- GSF
- GF
- GF-KEG
- ZGF
- ZIRK-GF
- Gigant
- MoSys



- Product Finder
- v_c / f_z
- M
- MF
- UNC
UN, UNS
- UNF
UNEF
- G, Rp
- NPT, NPTF
Rc, W
- BSW, BSF
- Pg
- EG (STI)
SELF-LOCK
- Tr
- Zubehör
Accessories
- Tech. Info
- BGF
- ZBGF
- GSF
- GF
- GF-KEG
- ZGF
- ZIRK-GF
- Gigant
- MoSys

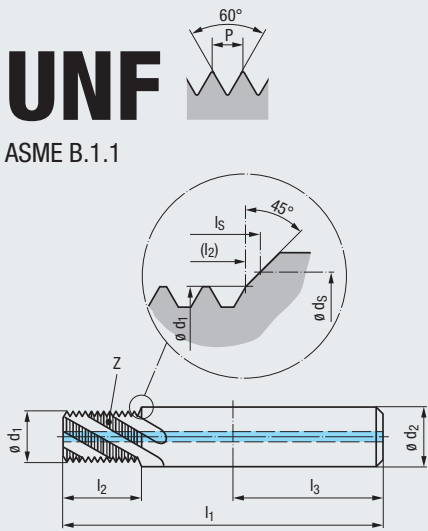

Einsatzgebiete – Material
Applications – material

Gewindetiefe
Thread depth

Werkzeug-Ident · Tool ident

ø D inch	P Gg/1" (tpi)	l ₁	l ₂	l ₃	ø d ₁	ø d ₂	ø d _s	l _s	Z	Dimens.- Ident	GF322101	GF322401	GF322701
											GSF-VHM 1,5xD R30-IKZ-HB	GSF-VHM 1,5xD R30-IKZ-HE	GSF-VHM 1,5xD R30-IKZ-HA
Nr. 10	32	55	7,6	36	3,8	6	5,13	8,1	3	.5041	●	●	●
Nr. 12	28	62	8,6	36	4,3	8	5,79	9,3	3	.5042	●	●	●
1/4	28	62	10,5	36	5,15	8	6,65	11,1	3	.5043	●	●	●
5/16	24	74	12,2	40	6,6	10	8,25	12,9	3	.5044	●	●	●
3/8	24	80	14,3	45	8,2	12	9,83	15	3	.5045	●	●	●
7/16	20	80	17,2	45	9,55	12	11,43	18	3	.5046	●	●	●
1/2	20	90	19,7	45	11,1	14	13	20,5	4	.5047	●	●	●
9/16	18	100	21,9	48	12,5	16	14,61	22,8	4	.5048	●	●	●
5/8	18	102	24,8	48	14,1	18	16,18	25,6	4	.5049	●	●	●
3/4	16	110	29,5	50	17	20	19,35	30,4	5	.5050	●	●	●

Gewindetiefe
Thread depth

Werkzeug-Ident · Tool ident

ø D inch	P Gg/1" (tpi)	l ₁	l ₂	l ₃	ø d ₁	ø d ₂	ø d _s	l _s	Z	Dimens.- Ident	GF332101	GF332401	GF332701
											GSF-VHM 2xD R30-IKZ-HB	GSF-VHM 2xD R30-IKZ-HE	GSF-VHM 2xD R30-IKZ-HA
Nr. 10	32	55	9,9	36	3,8	6	5,13	10,5	3	.5041	●	●	●
Nr. 12	28	62	11,4	36	4,3	8	5,79	12	3	.5042	●	●	●
1/4	28	62	13,2	36	5,15	8	6,65	13,8	3	.5043	●	●	●
5/16	24	74	16,4	40	6,6	10	8,25	17,1	3	.5044	●	●	●
3/8	24	80	19,6	45	8,2	12	9,83	20,3	3	.5045	●	●	●
7/16	20	80	22,3	45	9,55	12	11,43	23,1	3	.5046	●	●	●
1/2	20	90	26,1	45	11,1	14	13	26,9	4	.5047	●	●	●
9/16	18	100	29	48	12,5	16	14,61	29,9	4	.5048	●	●	●
5/8	18	102	33,2	48	14,1	18	16,18	34,1	4	.5049	●	●	●
3/4	16	110	39	50	17	20	19,35	40	5	.5050	●	●	●

Andere Abmessungen auf Anfrage
Other sizes upon request

VHM

R30

RH + LH

Z3 - Z5

DIN 6535

HB
HE
HA

90°

ø D

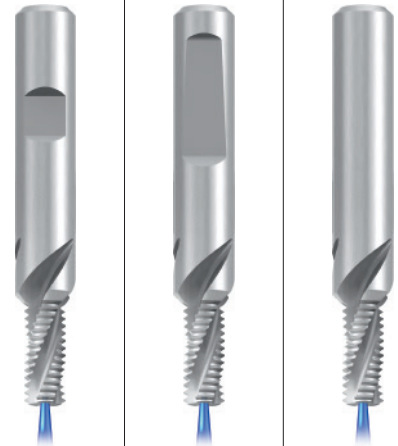

P 1.1-3.1 K 1.1-4.2 N 1.1-5
N 2.1-6 N 3.1-4.2, 5.2 S 1.1-2

1,5 x D

2 x D

UNF

ASME B.1.1

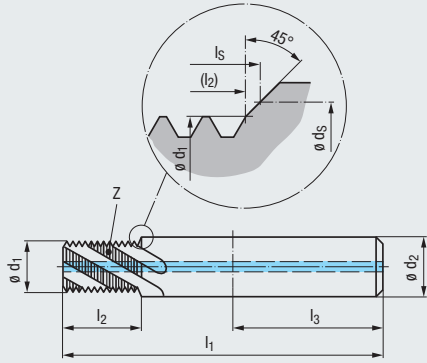

VHM	TICN
R30	RH + LH
Z3 - Z5	DIN 6535 HB HE HA
90°	ø D

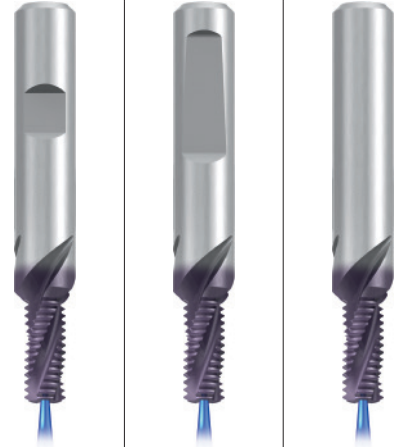

Einsatzgebiete – Material Applications – material **328**

P 1.1-3.1 M 1.1-2.1 K 1.1-4.2
N 1.1-2.7 N 3.1-5.2 S 1.1-2.2.1

Gewindetiefe Thread depth

1,5 x D

Werkzeug-Ident · Tool ident

ø D inch	P Gg/1" (tpi)	l ₁	l ₂	l ₃	ø d ₁	ø d ₂	ø d _S	l _S	Z	Dimens.- Ident	GF322106	GF322406	GF322706
											GSF-VHM 1,5xD R30-1KZ-HB TICN	GSF-VHM 1,5xD R30-1KZ-HE TICN	GSF-VHM 1,5xD R30-1KZ-HA TICN
Nr. 10	32	55	7,6	36	3,8	6	5,13	8,1	3	.5041	●	●	●
Nr. 12	28	62	8,6	36	4,3	8	5,79	9,3	3	.5042	●	●	●
1/4	28	62	10,5	36	5,15	8	6,65	11,1	3	.5043	●	●	●
5/16	24	74	12,2	40	6,6	10	8,25	12,9	3	.5044	●	●	●
3/8	24	80	14,3	45	8,2	12	9,83	15	3	.5045	●	●	●
7/16	20	80	17,2	45	9,55	12	11,43	18	3	.5046	●	●	●
1/2	20	90	19,7	45	11,1	14	13	20,5	4	.5047	●	●	●
9/16	18	100	21,9	48	12,5	16	14,61	22,8	4	.5048	●	●	●
5/8	18	102	24,8	48	14,1	18	16,18	25,6	4	.5049	●	●	●
3/4	16	110	29,5	50	17	20	19,35	30,4	5	.5050	●	●	●

Gewindetiefe Thread depth

2 x D

Werkzeug-Ident · Tool ident

ø D inch	P Gg/1" (tpi)	l ₁	l ₂	l ₃	ø d ₁	ø d ₂	ø d _S	l _S	Z	Dimens.- Ident	GF332106	GF332406	GF332706
											GSF-VHM 2xD R30-1KZ-HB TICN	GSF-VHM 2xD R30-1KZ-HE TICN	GSF-VHM 2xD R30-1KZ-HA TICN
Nr. 10	32	55	9,9	36	3,8	6	5,13	10,5	3	.5041	●	●	●
Nr. 12	28	62	11,4	36	4,3	8	5,79	12	3	.5042	●	●	●
1/4	28	62	13,2	36	5,15	8	6,65	13,8	3	.5043	●	●	●
5/16	24	74	16,4	40	6,6	10	8,25	17,1	3	.5044	●	●	●
3/8	24	80	19,6	45	8,2	12	9,83	20,3	3	.5045	●	●	●
7/16	20	80	22,3	45	9,55	12	11,43	23,1	3	.5046	●	●	●
1/2	20	90	26,1	45	11,1	14	13	26,9	4	.5047	●	●	●
9/16	18	100	29	48	12,5	16	14,61	29,9	4	.5048	●	●	●
5/8	18	102	33,2	48	14,1	18	16,18	34,1	4	.5049	●	●	●
3/4	16	110	39	50	17	20	19,35	40	5	.5050	●	●	●

Andere Abmessungen auf Anfrage
Other sizes upon request

Product Finder

v_c / f_z

M

MF

UNC
UN, UNS

UNF
UNEF

G, Rp

NPT, NPTF
Rc, W

BSW, BSF

Pg

EG (STI)
SELF-LOCK

Tr

Zubehör
Accessories

Tech. Info

BGF

ZBGF

GSF

GF

GF-KEG

ZGF

ZIRK-GF

Gigant

MoSys

- Product Finder
- v_c / f_z
- M
- MF
- UNC UN, UNS
- UNF UNEF
- G Rp
- NPT, NPTF Rc, W
- BSW, BSF
- Pg
- EG (STI) SELF-LOCK
- Tr
- Zubehör Accessories
- Tech. Info
- BGF
- ZBGF
- GSF
- GF
- GF-KEG
- ZGF
- ZIRK-GF
- Gigant
- MoSys

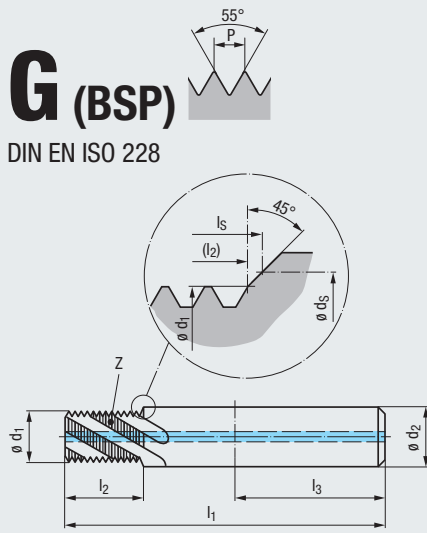

VHM

R30 **RH + LH**

Z3 - Z4 **DIN 6535**
 HB
 HE
 HA

90° **Ø D**

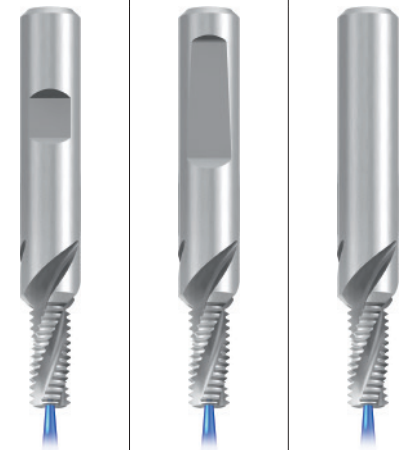

Einsatzgebiete – Material Applications – material **328**

P 1.1-3.1 **K 1.1-4.2** **N 1.1-5**
N 2.1-6 **N 3.1-4.2, 5.2** **S 1.1-2**

Gewindetiefe Thread depth

1,5 x D

Werkzeug-Ident · Tool ident

	GF322101	GF322401	GF322701
GSF-VHM 1,5xD R30-IKZ-HB	•	•	•
GSF-VHM 1,5xD R30-IKZ-HE	•	•	•
GSF-VHM 1,5xD R30-IKZ-HA	•	•	•

Nenngröße Nom. size

Dimens.-Ident

Ø D	P Gg/1" (tpi)	l ₁	l ₂	l ₃	Ø d ₁	Ø d ₂	Ø d ₃	l _s	Z	Dimens.-Ident
G 1/8	28	80	15	45	8,2	12	10	15,7	3	.4035
1/4	19	100	20,7	48	11	16	13,5	21,8	4	.4036
3/8	19	102	26,1	48	14,5	18	17	27,2	4	.4037

Gewindetiefe Thread depth

2 x D

Werkzeug-Ident · Tool ident

	GF332101	GF332401	GF332701
GSF-VHM 2xD R30-IKZ-HB	•	•	•
GSF-VHM 2xD R30-IKZ-HE	•	•	•
GSF-VHM 2xD R30-IKZ-HA	•	•	•

Nenngröße Nom. size

Dimens.-Ident

Ø D	P Gg/1" (tpi)	l ₁	l ₂	l ₃	Ø d ₁	Ø d ₂	Ø d ₃	l _s	Z	Dimens.-Ident
G 1/8	28	80	20,4	45	8,2	12	10	21,2	3	.4035
1/4	19	100	27,4	48	11	16	13,5	28,5	4	.4036
3/8	19	102	34,1	48	14,5	18	17	35,2	4	.4037

Andere Abmessungen auf Anfrage Other sizes upon request



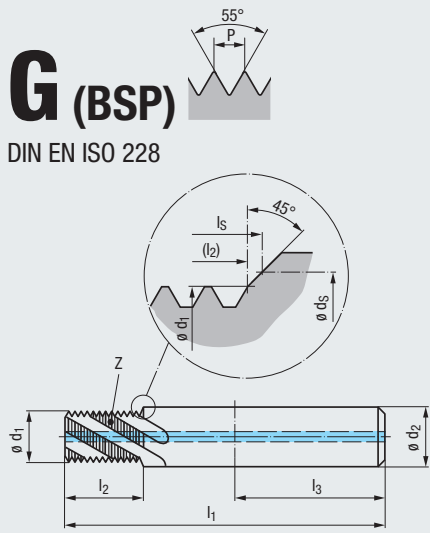

VHM	TICN
R30	RH + LH
Z3 - Z4	DIN 6535 HB HE HA
90°	∅ D

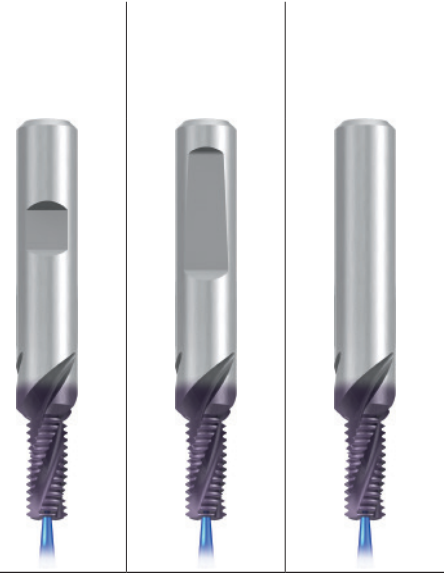

Product Finder

v_c / f_z

M

MF

UNC UN, UNS

UNF UNEF

G, Rp

NPT, NPTF Rc, W

BSW, BSF

Pg

EG (STI) SELF-LOCK

Tr

Zubehör Accessories

Tech. Info

BGF

ZBGF

GSF

GF

GF-KEG

ZGF

ZIRK-GF

Gigant

MoSys

Einsatzgebiete – Material Applications – material ▶▶ 328

P 1.1-3.1	M 1.1-2.1	K 1.1-4.2
N 1.1-2.7	N 3.1-5.2	S 1.1-2, 2.1

Gewindetiefe Thread depth **1,5 x D**

Werkzeug-Ident · Tool ident											GF322106	GF322406	GF322706
Nenngröße Nom. size										Dimens.-Ident	GSF-VHM 1,5xD R30-1KZ-HB TICN	GSF-VHM 1,5xD R30-1KZ-HE TICN	GSF-VHM 1,5xD R30-1KZ-HA TICN
∅ D	P Gg/1" (tpi)	l_1	l_2	l_3	$\varnothing d_1$	$\varnothing d_2$	$\varnothing d_s$	l_s	Z				
G 1/8	28	80	15	45	8,2	12	10	15,7	3	.4035	●	●	●
1/4	19	100	20,7	48	11	16	13,5	21,8	4	.4036	●	●	●
3/8	19	102	26,1	48	14,5	18	17	27,2	4	.4037	●	●	●

Gewindetiefe Thread depth **2 x D**

Werkzeug-Ident · Tool ident											GF332106	GF332406	GF332706
Nenngröße Nom. size										Dimens.-Ident	GSF-VHM 2xD R30-1KZ-HB TICN	GSF-VHM 2xD R30-1KZ-HE TICN	GSF-VHM 2xD R30-1KZ-HA TICN
∅ D	P Gg/1" (tpi)	l_1	l_2	l_3	$\varnothing d_1$	$\varnothing d_2$	$\varnothing d_s$	l_s	Z				
G 1/8	28	80	20,4	45	8,2	12	10	21,2	3	.4035	●	●	●
1/4	19	100	27,4	48	11	16	13,5	28,5	4	.4036	●	●	●
3/8	19	102	34,1	48	14,5	18	17	35,2	4	.4037	●	●	●

Andere Abmessungen auf Anfrage
Other sizes upon request

● = Lagerwerkzeug, siehe Preisliste · Stock tool, see price list
○ = Kurzfristig lieferbar, Preis auf Anfrage · Available on short notice, price upon inquiry

- Product Finder
- v_c / f_z
- M
- MF
- UNC UN, UNS
- UNF UNEF
- G, Rp
- NPT, NPTF Rc, W
- BSW, BSF
- Pg
- EG (ST) SELF-LOCK
- Tr
- Zubehör Accessories
- Tech. Info
- BGF
- ZBGF
- GSF**
- GF
- GF-KEG
- ZGF
- ZIRK-GF
- Gigant
- MoSys

LK-M

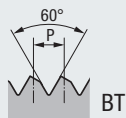

EMUGE-Norm · EMUGE Standard

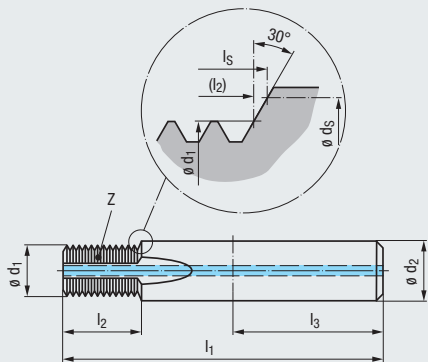

VHM

RH + LH

Z3 - Z4



DIN 6535



120°



$\varnothing D$

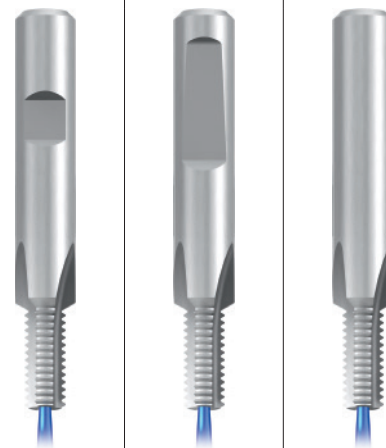

Einsatzgebiete – Material
Applications – material

» 328

P 1.1-5.1 K 1.1-4.2 N 1.1-5, 2.1-6
N 3.1-2 N 4.1-2, 5.2 S 1.1-3

Gewindetiefe
Thread depth

2 x D

Werkzeug-Ident · Tool ident

GF333101 GF333401 GF333701

GSF-VHM 2xD IKZ-HB GSF-VHM 2xD IKZ-HE GSF-VHM 2xD IKZ-HA

	$\varnothing D$ mm	P mm	l_1	l_2	l_3	$\varnothing d_1$	$\varnothing d_2$	$\varnothing d_s$	l_s	Z	Dimens.- Ident	GF333101	GF333401	GF333701
												GSF-VHM 2xD IKZ-HB	GSF-VHM 2xD IKZ-HE	GSF-VHM 2xD IKZ-HA
LK-M	5	0,8	55	10,7	36	4	6	5,3	11,1	3	.1050	●	●	●
	6	1	62	12,4	36	4,8	8	6,3	12,8	3	.1052	●	●	●
	8	1,25	74	16,7	40	6,5	10	8,3	17,3	3	.1054	●	●	●
	10	1,5	80	20,1	45	8,2	12	10,3	20,7	3	.1056	●	●	●
	12	1,75	90	25,2	45	9,9	14	12,3	25,9	4	.1058	●	●	●

Andere Abmessungen auf Anfrage
Other sizes upon request

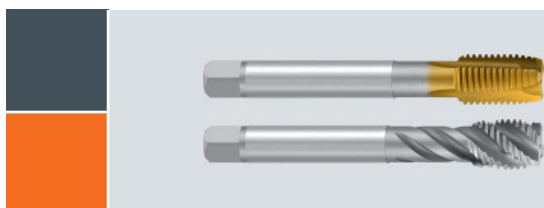

Gewindebohrer für Metrisches
SELF-LOCK-Gewinde
siehe Seite 228 - 231

Taps for Metric SELF-LOCK thread,
see page 228 - 231

LK-M

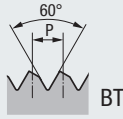

EMUGE-Norm · EMUGE Standard

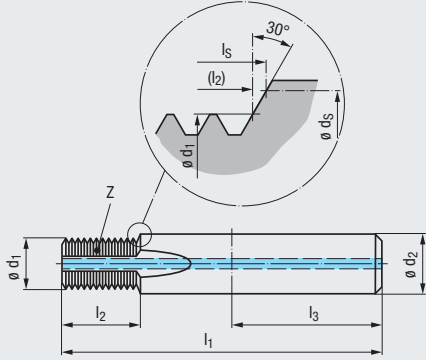

VHM	TICN
	RH + LH
Z3 - Z4	DIN 6535
	HB
	HE
	HA
120°	θD

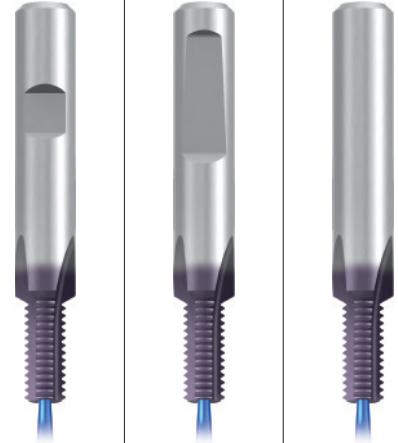

Einsatzgebiete – Material Applications – material 328

P 1.1-5.1	M 1.1-4.1	K 1.1-4.2
N 1.1-5.2	S 1.1-2.6	H 1.1-2

Gewindetiefe Thread depth

2 x D

Werkzeug-Ident · Tool ident

GF333106 GF333406 GF333706

θD mm	P mm	l_1	l_2	l_3	θd_1	θd_2	θd_s	l_s	Z	Dimens.- Ident	GF333106	GF333406	GF333706
											GSF-VHM 2xD IKZ-HB TICN	GSF-VHM 2xD IKZ-HE TICN	GSF-VHM 2xD IKZ-HA TICN
LK-M 5	0,8	55	10,7	36	4	6	5,3	11,1	3	.1050	●	●	●
6	1	62	12,4	36	4,8	8	6,3	12,8	3	.1052	●	●	●
8	1,25	74	16,7	40	6,5	10	8,3	17,3	3	.1054	●	●	●
10	1,5	80	20,1	45	8,2	12	10,3	20,7	3	.1056	●	●	●
12	1,75	90	25,2	45	9,9	14	12,3	25,9	4	.1058	●	●	●

Andere Abmessungen auf Anfrage
Other sizes upon request

Product Finder

v_c / f_z

M

MF

UNC UN, UNS

UNF UNEF

G, Rp

NPT, NPTF Rc, W

BSW, BSF

Pg

EG (STI) SELF-LOCK

Tr

Zubehör Accessories

Tech. Info

BGF

ZBGF

GSF

GF

GF-KEG

ZGF

ZIRK-GF

Gigant

MoSys

Product Finder

v_c / f_z

M

MF

UNC
UN, UNS

UNF
UNEF

G, Rp

NPT, NPTF
Rc, W

BSW, BSF

Pg

EG (STI)
SELF-LOCK

Tr

Zubehör
Accessories

Tech. Info

BGF

ZBGF

GSF

GF

GF-KEG

ZGF

ZIRK-GF

Gigant

MoSys

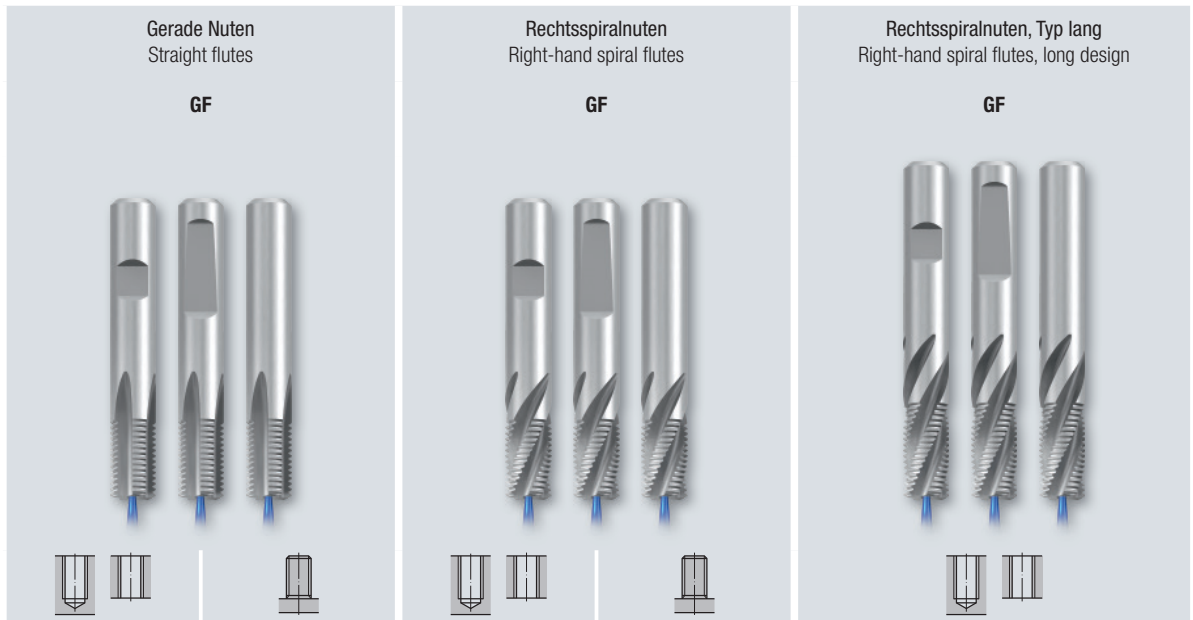

Seite · Page

M, MF	382	385	383		384
UN	390				391
G (BSP), Rp (BSPP), W	393	393	394	394	
Pg	396	396	397	397	
LK-M	398				

Mögliche Modifikationen · Possible modifications



Stirnflase ohne/mit Stirnschnitt
Face chamfer with/without cutting face



AZR/AZ (ausgesetzte Zähne)
AZR/AZ (alternating teeth)



Unvollständigen Gang entfernen
Remove incomplete thread



IKZN (innere Kühlschmierstoff-Zufuhr mit Austritt in den Nuten)
IKZN (internal coolant supply exiting in the flutes)



Halsfreischliff
Recessed neck



Schaftkühlfluten
Coolant grooves along the shank

Eine Beschreibung dieser Modifikationsmöglichkeiten finden Sie auf Seite 456 - 457
For a description of these modifications, see pages 456 - 457

Gewindefräszyklus · Thread milling cycle

GF, GF-Z

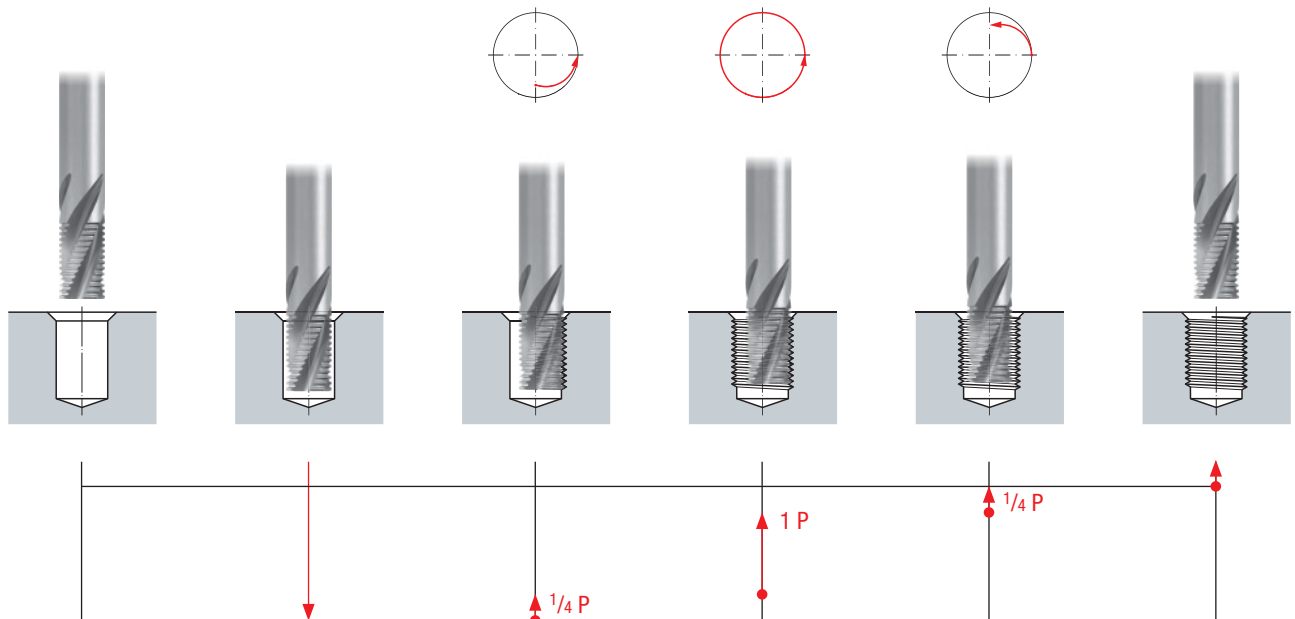

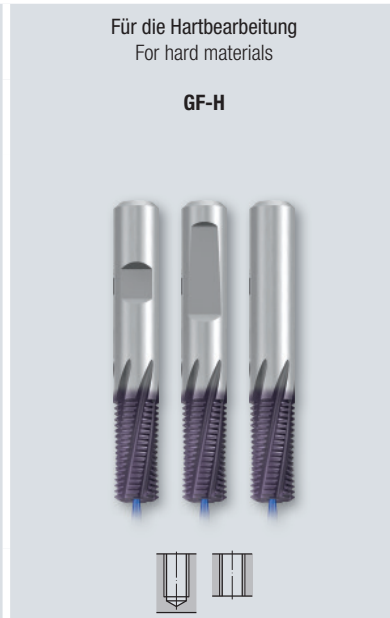
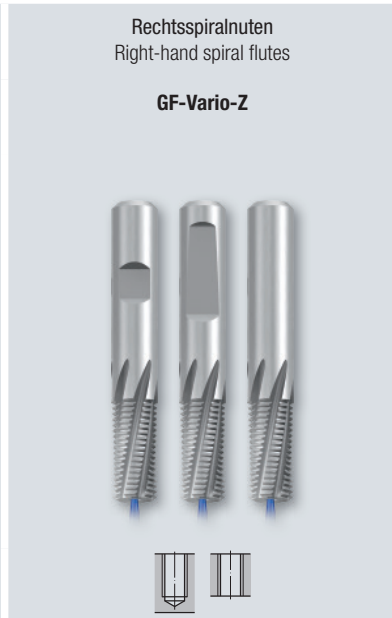

Seite · Page

386	387 - 388	389	M, MF
	392		UN
	395		G (BSP), Rp (BSPP), W
			Pg
			LK-M

Product Finder

v_c / f_z

M

MF

UNC
UN, UNS

UNF
UNEF

G, Rp

NPT, NPTF
Rc, W

BSW, BSF

Pg

EG (STI)
SELF-LOCK

Tr

Zubehör
Accessories

Tech. Info

BGF

ZBGF

GSF

GF

GF-KEG

ZGF

ZIRK-GF

Gigant

MoSys



Mögliche Modifikationen · Possible modifications



Stirnfase ohne/mit Stirnschnitt
Face chamfer with/without cutting face



AZR/AZ (ausgesetzte Zähne)
AZR/AZ (alternating teeth)



Unvollständigen Gang entfernen
Remove incomplete thread



IKZN (innere Kühlschmierstoff-Zufuhr mit Austritt in den Nuten)
IKZN (internal coolant supply exiting in the flutes)



Halsfreischliff
Recessed neck



Schaftkühlfluten
Coolant grooves along the shank

Eine Beschreibung dieser Modifikationsmöglichkeiten finden Sie auf Seite 456 - 457
For a description of these modifications, see pages 456 - 457

Gewindefräszyklus · Thread milling cycle

GF-Vario-Z, GF-H

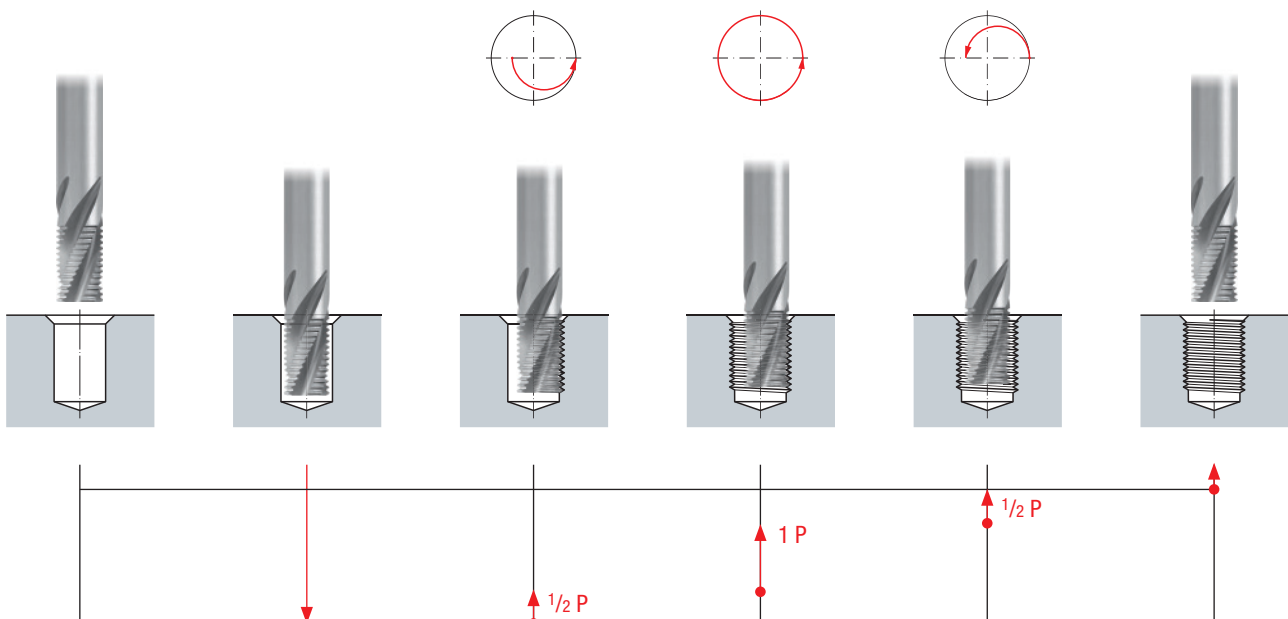

- Product Finder
- v_c / f_z
- M
- MF
- UNC UN, UNS
- UNF UNEF
- G, Rp
- NPT, NPTF Rc, W
- BSW, BSF
- Pg
- EG (STI) SELF-LOCK
- Tr
- Zubehör Accessories
- Tech. Info
- BGF
- ZBGF
- GSF
- GF
- GF-KEG
- ZGF
- ZIRK-GF
- Gigant
- MoSys

M, MF

DIN 13



Für Innengewinde
For internal threads

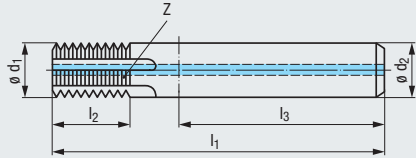

VHM

RH + LH

Z3 - Z5



DIN 6535



$\varnothing D$



Einsatzgebiete – Material
Applications – material

» 328

P 1.1-5.1 K 1.1-4.2 N 1.1-5, 2.1-6
N 3.1-2 N 4.1-2, 5.2 S 1.1-3

P mm	$\varnothing D_{min.}$ mm	$\varnothing d_1$ mm	$\varnothing d_2$	l_1	l_2	l_3	Z	GF-VHM IKZ-HB	GF-VHM IKZ-HE	GF-VHM IKZ-HA
0,5	10	7,9	8	63	12,2	36	3	GF163101.9506	● GF163401.9506	● GF163701.9506
0,5	12	9,9	10	70	16,2	40	4	GF163211.9506	● GF163511.9506	● GF163811.9506
0,75	11	7,9	8	63	12,3	36	3	GF163101.9509	● GF163401.9509	● GF163701.9509
0,75	13	9,9	10	70	16,8	40	4	GF163211.9509	● GF163511.9509	● GF163811.9509
1	14	9,9	10	70	16,4	40	4	GF163211.9512	● GF163511.9512	● GF163811.9512
1	16	11,9	12	80	20,4	45	4	GF163121.9512	● GF163421.9512	● GF163721.9512
1	22	15,9	16	90	25,4	48	5	GF163131.9512	● GF163431.9512	● GF163731.9512
1	27	19,9	20	105	32,4	50	5	GF163151.9512	● GF163451.9512	● GF163751.9512
1,5	14	9,9	10	70	17,1	40	4	GF163211.9514	● GF163511.9514	● GF163811.9514
1,5	16	11,9	12	80	21,6	45	4	GF163121.9514	● GF163421.9514	● GF163721.9514
1,5	22	15,9	16	90	26,1	48	5	GF163131.9514	● GF163431.9514	● GF163731.9514
1,5	27	19,9	20	105	33,6	50	5	GF163151.9514	● GF163451.9514	● GF163751.9514
2	18	11,9	12	80	20,9	45	4	GF163121.9516	● GF163421.9516	● GF163721.9516
2	22	15,9	16	90	26,9	48	5	GF163131.9516	● GF163431.9516	● GF163731.9516
2	27	19,9	20	105	32,9	50	5	GF163151.9516	● GF163451.9516	● GF163751.9516
3	24	15,9	16	90	28,3	48	5	GF163131.9518	● GF163431.9518	● GF163731.9518
3	30	19,9	20	105	34,3	50	5	GF163151.9518	● GF163451.9518	● GF163751.9518

TICN



Einsatzgebiete – Material
Applications – material

» 328

P 1.1-5.1 M 1.1-4.1 K 1.1-4.2
N 1.1-5.2 S 1.1-2.6 H 1.1-2

P mm	$\varnothing D_{min.}$ mm	$\varnothing d_1$ mm	$\varnothing d_2$	l_1	l_2	l_3	Z	GF-VHM IKZ-HB TICN	GF-VHM IKZ-HE TICN	GF-VHM IKZ-HA TICN
0,5	10	7,9	8	63	12,2	36	3	GF163106.9506	● GF163406.9506	● GF163706.9506
0,5	12	9,9	10	70	16,2	40	4	GF163216.9506	● GF163516.9506	● GF163816.9506
0,75	11	7,9	8	63	12,3	36	3	GF163106.9509	● GF163406.9509	● GF163706.9509
0,75	13	9,9	10	70	16,8	40	4	GF163216.9509	● GF163516.9509	● GF163816.9509
1	14	9,9	10	70	16,4	40	4	GF163216.9512	● GF163516.9512	● GF163816.9512
1	16	11,9	12	80	20,4	45	4	GF163126.9512	● GF163426.9512	● GF163726.9512
1	22	15,9	16	90	25,4	48	5	GF163136.9512	● GF163436.9512	● GF163736.9512
1	27	19,9	20	105	32,4	50	5	GF163156.9512	● GF163456.9512	● GF163756.9512
1,5	14	9,9	10	70	17,1	40	4	GF163216.9514	● GF163516.9514	● GF163816.9514
1,5	16	11,9	12	80	21,6	45	4	GF163126.9514	● GF163426.9514	● GF163726.9514
1,5	22	15,9	16	90	26,1	48	5	GF163136.9514	● GF163436.9514	● GF163736.9514
1,5	27	19,9	20	105	33,6	50	5	GF163156.9514	● GF163456.9514	● GF163756.9514
2	18	11,9	12	80	20,9	45	4	GF163126.9516	● GF163426.9516	● GF163726.9516
2	22	15,9	16	90	26,9	48	5	GF163136.9516	● GF163436.9516	● GF163736.9516
2	27	19,9	20	105	32,9	50	5	GF163156.9516	● GF163456.9516	● GF163756.9516
3	24	15,9	16	90	28,3	48	5	GF163136.9518	● GF163436.9518	● GF163736.9518
3	30	19,9	20	105	34,3	50	5	GF163156.9518	● GF163456.9518	● GF163756.9518

Andere Steigungen auf Anfrage
Tools for different thread pitch upon request

M, MF

DIN 13

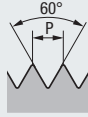

VHM

R30

RH + LH

Z3 - Z5



DIN 6535



Für Innengewinde
For internal threads

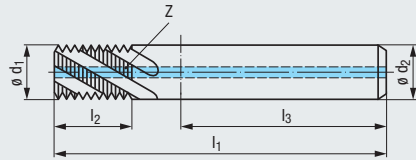

Einsatzgebiete – Material
Applications – material

» 328

P 1.1-3.1 K 1.1-4.2 N 1.1-5
N 2.1-6 N 3.1-4.2, 5.2 S 1.1-2

P mm	∅ D _{min.} mm	∅ d ₁ mm	∅ d ₂	l ₁	l ₂	l ₃	Z	GF-VHM R30-IKZ-HB	GF-VHM R30-IKZ-HE	GF-VHM R30-IKZ-HA
0,5	10	7,9	8	63	12,2	36	3	GF162101.9506 ●	GF162401.9506 ●	GF162701.9506 ●
0,75	11	7,9	8	63	12,3	36	3	GF162101.9509 ●	GF162401.9509 ●	GF162701.9509 ●
1	14	9,9	10	70	16,4	40	4	GF162211.9512 ●	GF162511.9512 ●	GF162811.9512 ●
1	16	11,9	12	80	20,4	45	4	GF162121.9512 ●	GF162421.9512 ●	GF162721.9512 ●
1	22	15,9	16	90	25,4	48	5	GF162131.9512 ●	GF162431.9512 ●	GF162731.9512 ●
1	27	19,9	20	105	32,4	50	5	GF162151.9512 ●	GF162451.9512 ●	GF162751.9512 ●
1,5	14	9,9	10	70	17,1	40	4	GF162211.9514 ●	GF162511.9514 ●	GF162811.9514 ●
1,5	16	11,9	12	80	21,6	45	4	GF162121.9514 ●	GF162421.9514 ●	GF162721.9514 ●
1,5	22	15,9	16	90	26,1	48	5	GF162131.9514 ●	GF162431.9514 ●	GF162731.9514 ●
1,5	27	19,9	20	105	33,6	50	5	GF162151.9514 ●	GF162451.9514 ●	GF162751.9514 ●
2	18	11,9	12	80	20,9	45	4	GF162121.9516 ●	GF162421.9516 ●	GF162721.9516 ●
2	22	15,9	16	90	26,9	48	5	GF162131.9516 ●	GF162431.9516 ●	GF162731.9516 ●
2	27	19,9	20	105	32,9	50	5	GF162151.9516 ●	GF162451.9516 ●	GF162751.9516 ●
3	24	15,9	16	90	28,3	48	5	GF162131.9518 ●	GF162431.9518 ●	GF162731.9518 ●
3	30	19,9	20	105	34,9	50	5	GF162151.9518 ●	GF162451.9518 ●	GF162751.9518 ●

TICN

Einsatzgebiete – Material
Applications – material

» 328

P 1.1-3.1 M 1.1-2.1 K 1.1-4.2
N 1.1-2.7 N 3.1-5.2 S 1.1-2, 2.1

P mm	∅ D _{min.} mm	∅ d ₁ mm	∅ d ₂	l ₁	l ₂	l ₃	Z	GF-VHM R30-IKZ-HB TICN	GF-VHM R30-IKZ-HE TICN	GF-VHM R30-IKZ-HA TICN
0,5	10	7,9	8	63	12,2	36	3	GF162106.9506 ●	GF162406.9506 ●	GF162706.9506 ●
0,75	11	7,9	8	63	12,3	36	3	GF162106.9509 ●	GF162406.9509 ●	GF162706.9509 ●
1	14	9,9	10	70	16,4	40	4	GF162216.9512 ●	GF162516.9512 ●	GF162816.9512 ●
1	16	11,9	12	80	20,4	45	4	GF162126.9512 ●	GF162426.9512 ●	GF162726.9512 ●
1	22	15,9	16	90	25,4	48	5	GF162136.9512 ●	GF162436.9512 ●	GF162736.9512 ●
1	27	19,9	20	105	32,4	50	5	GF162156.9512 ●	GF162456.9512 ●	GF162756.9512 ●
1,5	14	9,9	10	70	17,1	40	4	GF162216.9514 ●	GF162516.9514 ●	GF162816.9514 ●
1,5	16	11,9	12	80	21,6	45	4	GF162126.9514 ●	GF162426.9514 ●	GF162726.9514 ●
1,5	22	15,9	16	90	26,1	48	5	GF162136.9514 ●	GF162436.9514 ●	GF162736.9514 ●
1,5	27	19,9	20	105	33,6	50	5	GF162156.9514 ●	GF162456.9514 ●	GF162756.9514 ●
2	18	11,9	12	80	20,9	45	4	GF162126.9516 ●	GF162426.9516 ●	GF162726.9516 ●
2	22	15,9	16	90	26,9	48	5	GF162136.9516 ●	GF162436.9516 ●	GF162736.9516 ●
2	27	19,9	20	105	32,9	50	5	GF162156.9516 ●	GF162456.9516 ●	GF162756.9516 ●
3	24	15,9	16	90	28,3	48	5	GF162136.9518 ●	GF162436.9518 ●	GF162736.9518 ●
3	30	19,9	20	105	34,9	50	5	GF162156.9518 ●	GF162456.9518 ●	GF162756.9518 ●

Andere Steigungen auf Anfrage
Tools for different thread pitch upon request

Product Finder

v_c / f_z

M

MF

UNC
UN, UNS

UNF
UNEF

G, Rp

NPT, NPTF
Rc, W

BSW, BSF

Pg

EG (STI)
SELF-LOCK

Tr

Zubehör
Accessories

Tech. Info

BGF

ZBGF

GSF

GF

GF-KEG

ZGF

ZIRK-GF

Gigant

MoSys

- Product Finder
- v_c / f_z
- M
- MF
- UNC
UN, UNS
- UNF
UNEF
- G, Rp
- NPT, NPTF
Rc, W
- BSW, BSF
- Pg
- EG (STI)
SELF-LOCK
- Tr
- Zubehör
Accessories
- Tech. Info
- BGF
- ZBGF
- GSF
- GF
- GF-KEG
- ZGF
- ZIRK-GF
- Gigant
- MoSys

M, MF

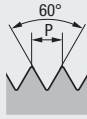
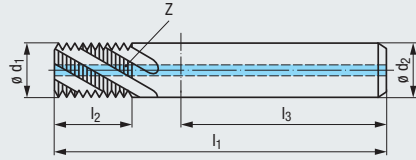
DIN 13

Für Innengewinde
For internal threads

VHM
R30
RH + LH
Z4 - Z5
DIN 6535

 $\varnothing D$

Einsatzgebiete – Material
Applications – material

▶▶ 328

P 1.1-3.1 **K 1.1-4.2** **N 1.1-5**
N 2.1-6 **N 3.1-4.2, 5.2** **S 1.1-2**

P mm	$\varnothing D_{min.}$ mm	$\varnothing d_1$ mm	$\varnothing d_2$	l_1	l_2	l_3	Z	GF-VHM R30-Ig-IKZ-HB		GF-VHM R30-Ig-IKZ-HE		GF-VHM R30-Ig-IKZ-HA	
								●	●	●	●	●	●
1	14	9,9	10	80	20,4	40	4	GF162311.9512	●	GF162611.9512	●	GF162911.9512	●
1	16	11,9	12	90	25,4	45	4	GF162321.9512	●	GF162621.9512	●	GF162921.9512	●
1	22	15,9	16	100	32,4	48	5	GF162331.9512	●	GF162631.9512	●	GF162931.9512	●
1	27	19,9	20	115	40,4	50	5	GF162351.9512	●	GF162651.9512	●	GF162951.9512	●
1,5	14	9,9	10	80	21,6	40	4	GF162311.9514	●	GF162611.9514	●	GF162911.9514	●
1,5	16	11,9	12	90	26,1	45	4	GF162321.9514	●	GF162621.9514	●	GF162921.9514	●
1,5	22	15,9	16	100	33,6	48	5	GF162331.9514	●	GF162631.9514	●	GF162931.9514	●
1,5	27	19,9	20	115	41,1	50	5	GF162351.9514	●	GF162651.9514	●	GF162951.9514	●
2	18	11,9	12	90	26,9	45	4	GF162321.9516	●	GF162621.9516	●	GF162921.9516	●
2	22	15,9	16	100	32,9	48	5	GF162331.9516	●	GF162631.9516	●	GF162931.9516	●
2	27	19,9	20	115	40,9	50	5	GF162351.9516	●	GF162651.9516	●	GF162951.9516	●
3	24	15,9	16	100	34,3	48	5	GF162331.9518	●	GF162631.9518	●	GF162931.9518	●
3	30	19,9	20	115	43,3	50	5	GF162351.9518	●	GF162651.9518	●	GF162951.9518	●

TICN

Einsatzgebiete – Material
Applications – material

▶▶ 328

P 1.1-3.1 **M 1.1-2.1** **K 1.1-4.2**
N 1.1-2.7 **N 3.1-5.2** **S 1.1-2, 2.1**

P mm	$\varnothing D_{min.}$ mm	$\varnothing d_1$ mm	$\varnothing d_2$	l_1	l_2	l_3	Z	GF-VHM R30-Ig-IKZ-HB TICN		GF-VHM R30-Ig-IKZ-HE TICN		GF-VHM R30-Ig-IKZ-HA TICN	
								●	●	●	●	●	●
1	14	9,9	10	80	20,4	40	4	GF162316.9512	●	GF162616.9512	●	GF162916.9512	●
1	16	11,9	12	90	25,4	45	4	GF162326.9512	●	GF162626.9512	●	GF162926.9512	●
1	22	15,9	16	100	32,4	48	5	GF162336.9512	●	GF162636.9512	●	GF162936.9512	●
1	27	19,9	20	115	40,4	50	5	GF162356.9512	●	GF162656.9512	●	GF162956.9512	●
1,5	14	9,9	10	80	21,6	40	4	GF162316.9514	●	GF162616.9514	●	GF162916.9514	●
1,5	16	11,9	12	90	26,1	45	4	GF162326.9514	●	GF162626.9514	●	GF162926.9514	●
1,5	22	15,9	16	100	33,6	48	5	GF162336.9514	●	GF162636.9514	●	GF162936.9514	●
1,5	27	19,9	20	115	41,1	50	5	GF162356.9514	●	GF162656.9514	●	GF162956.9514	●
2	18	11,9	12	90	26,9	45	4	GF162326.9516	●	GF162626.9516	●	GF162926.9516	●
2	22	15,9	16	100	32,9	48	5	GF162336.9516	●	GF162636.9516	●	GF162936.9516	●
2	27	19,9	20	115	40,9	50	5	GF162356.9516	●	GF162656.9516	●	GF162956.9516	●
3	24	15,9	16	100	34,3	48	5	GF162336.9518	●	GF162636.9518	●	GF162936.9518	●
3	30	19,9	20	115	43,3	50	5	GF162356.9518	●	GF162656.9518	●	GF162956.9518	●

Andere Steigungen auf Anfrage
Tools for different thread pitch upon request

M, MF

DIN 13

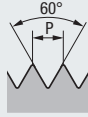

Für Außengewinde
For external threads

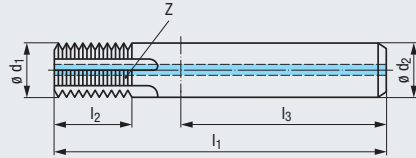

VHM

RH + LH

Z4 - Z5



DIN 6535



Einsatzgebiete – Material
Applications – material

» 328

P 1.1-5.1 K 1.1-4.2 N 1.1-5, 2.1-6
N 3.1-2 N 4.1-2, 5.2 S 1.1-3

P mm	∅ D _{min.} mm	∅ d ₁ mm	∅ d ₂	l ₁	l ₂	l ₃	Z	GF-VHM Ext.-IKZ-HB	GF-VHM Ext.-IKZ-HE	GF-VHM Ext.-IKZ-HA
1	10	9,9	10	70	16,5	40	4	GF161211.9512 ●	GF161511.9512 ●	GF161811.9512 ●
1	12	11,9	12	80	20,5	45	4	GF161121.9512 ●	GF161421.9512 ●	GF161721.9512 ●
1,5	12	11,9	12	80	21,75	45	4	GF161121.9514 ●	GF161421.9514 ●	GF161721.9514 ●
1,5	16	15,9	16	90	26,25	48	5	GF161131.9514 ●	GF161431.9514 ●	GF161731.9514 ●
1,5	20	19,9	20	105	33,75	50	5	GF161151.9514 ●	GF161451.9514 ●	GF161751.9514 ●
2	16	15,9	16	90	27	48	5	GF161131.9516 ●	GF161431.9516 ●	GF161731.9516 ●
2	20	19,9	20	105	33	50	5	GF161151.9516 ●	GF161451.9516 ●	GF161751.9516 ●
3	20	19,9	20	105	34,5	50	5	GF161151.9518 ●	GF161451.9518 ●	GF161751.9518 ●

TICN



Einsatzgebiete – Material
Applications – material

» 328

P 1.1-5.1 M 1.1-4.1 K 1.1-4.2
N 1.1-5.2 S 1.1-2.6 H 1.1-2

P mm	∅ D _{min.} mm	∅ d ₁ mm	∅ d ₂	l ₁	l ₂	l ₃	Z	GF-VHM Ext.-IKZ-HB TICN	GF-VHM Ext.-IKZ-HE TICN	GF-VHM Ext.-IKZ-HA TICN
1	10	9,9	10	70	16,5	40	4	GF161216.9512 ●	GF161516.9512 ●	GF161816.9512 ●
1	12	11,9	12	80	20,5	45	4	GF161126.9512 ●	GF161426.9512 ●	GF161726.9512 ●
1,5	12	11,9	12	80	21,75	45	4	GF161126.9514 ●	GF161426.9514 ●	GF161726.9514 ●
1,5	16	15,9	16	90	26,25	48	5	GF161136.9514 ●	GF161436.9514 ●	GF161736.9514 ●
1,5	20	19,9	20	105	33,75	50	5	GF161156.9514 ●	GF161456.9514 ●	GF161756.9514 ●
2	16	15,9	16	90	27	48	5	GF161136.9516 ●	GF161436.9516 ●	GF161736.9516 ●
2	20	19,9	20	105	33	50	5	GF161156.9516 ●	GF161456.9516 ●	GF161756.9516 ●
3	20	19,9	20	105	34,5	50	5	GF161156.9518 ●	GF161456.9518 ●	GF161756.9518 ●

Andere Steigungen auf Anfrage

Tools for different thread pitch upon request

Mit Rechtsspiralnuten auf Anfrage

With right-hand spiral flutes upon request

Product
Finder

v_c / f_z

M

MF

UNC
UN, UNS

UNF
UNEF

G, Rp

NPT, NPTF
Rc, W

BSW, BSF

Pg

EG (STI)
SELF-LOCK

Tr

Zubehör
Accessories

Tech. Info

BGF

ZBGF

GSF

GF

GF-KEG

ZGF

ZIRK-GF

Gigant

MoSys



Product Finder

v_c / f_z

M

MF

UNC
UN, UNS

UNF
UNEF

G, Rp

NPT, NPTF
Rc, W

BSW, BSF

Pg

EG (STI)
SELF-LOCK

Tr

Zubehör
Accessories

Tech. Info

BGF

ZBGF

GSF

GF

GF-KEG

ZGF

ZIRK-GF

Gigant

MoSys

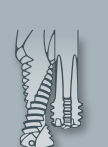

M, MF

DIN 13

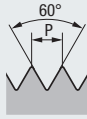

Für Innengewinde
For internal threads

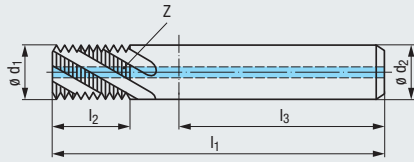

VHM

R15

RH + LH

Z6

DIN 6535



$\varnothing D$



Mit höherer Nutenzahl
With increased number of flutes

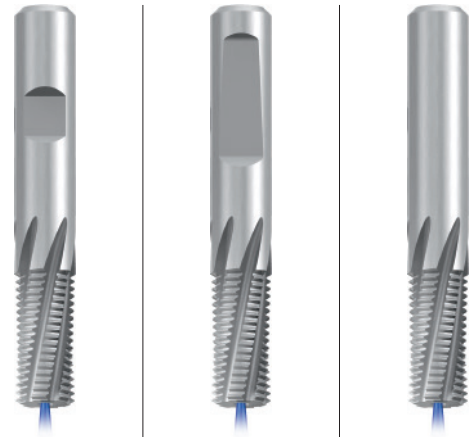

Einsatzgebiete – Material
Applications – material

» 328

P 1.1-5.1 K 1.1-4.2 N 1.1-5, 2.1-6
N 3.1-2 N 4.1-2, 5.2 S 1.1-3

P mm	$\varnothing D_{min.}$ mm	$\varnothing d_1$ mm	$\varnothing d_2$	l_1	l_2	l_3	Z	GF-Z-VHM R15- IKZ-HB	GF-Z-VHM R15- IKZ-HE	GF-Z-VHM R15- IKZ-HA
1	14	9,9	10	70	20,4	40	6	GF165361.9512	GF165661.9512	GF165961.9512
1,5	16	11,9	12	80	26,1	45	6	GF165371.9514	GF165671.9514	GF165971.9514
2	22	15,9	16	90	32,9	48	6	GF165381.9516	GF165681.9516	GF165981.9516
3	30	19,9	20	105	43,3	50	6	GF165391.9518	GF165691.9518	GF165991.9518

TICN



Einsatzgebiete – Material
Applications – material

» 328

P 1.1-5.1 M 1.1-4.1 K 1.1-4.2
N 1.1-5.2 S 1.1-2.6 H 1.1-2

P mm	$\varnothing D_{min.}$ mm	$\varnothing d_1$ mm	$\varnothing d_2$	l_1	l_2	l_3	Z	GF-Z-VHM R15- IKZ-HB TICN	GF-Z-VHM R15- IKZ-HE TICN	GF-Z-VHM R15- IKZ-HA TICN
1	14	9,9	10	70	20,4	40	6	GF165366.9512	GF165666.9512	GF165966.9512
1,5	16	11,9	12	80	26,1	45	6	GF165376.9514	GF165676.9514	GF165976.9514
2	22	15,9	16	90	32,9	48	6	GF165386.9516	GF165686.9516	GF165986.9516
3	30	19,9	20	105	43,3	50	6	GF165396.9518	GF165696.9518	GF165996.9518

Andere Steigungen auf Anfrage
Tools for different thread pitch upon request

M, MF

DIN 13

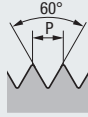

VHM

R15

RH + LH

Z4 - Z6



DIN 6535



Für Innengewinde
For internal threads

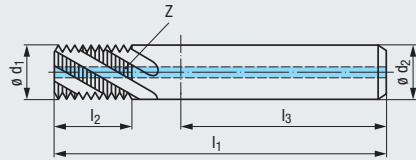

Mit höherer Nutenzahl
With increased number of flutes

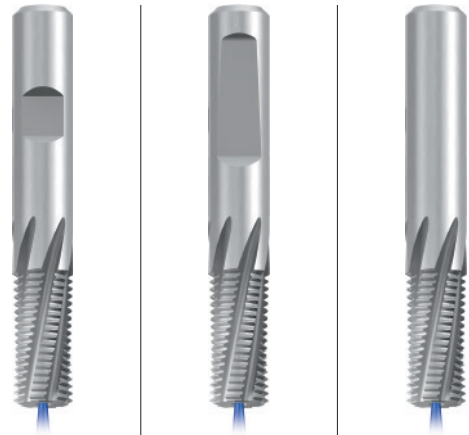

Einsatzgebiete – Material
Applications – material

328

P 1.1-5.1 K 1.1-4.2 N 1.1-5, 2.1-6
N 3.1-2 N 4.1-2, 5.2 S 1.1-3

P mm	$\varnothing D$	$\varnothing d_1$ mm	$\varnothing d_2$	l_1	l_2	l_3	Z	GF-VZ-VHM R15-IKZ-HB	GF-VZ-VHM R15-IKZ-HE	GF-VZ-VHM R15-IKZ-HA
0,5	$\geq M 3$	2,4	6	51	6,2	36	4	GFB35101.0030 ●	GFB35401.0030 ●	GFB35701.0030 ●
0,7	$\geq M 4$	3,15	6	55	8,7	36	4	GFB35101.0040 ●	GFB35401.0040 ●	GFB35701.0040 ●
0,8	$\geq M 5$	4	6	55	10,8	36	4	GFB35101.0050 ●	GFB35401.0050 ●	GFB35701.0050 ●
1	$\geq M 6$	4,8	6	55	12,4	36	4	GFB35101.0060 ●	GFB35401.0060 ●	GFB35701.0060 ●
1,25	$\geq M 8$	6,5	8	63	16,8	36	4	GFB35101.0080 ●	GFB35401.0080 ●	GFB35701.0080 ●
1,5	$\geq M10$	8,2	10	70	21,7	40	5	GFB35101.0100 ●	GFB35401.0100 ●	GFB35701.0100 ●
1,75	$\geq M12$	9,9	10	74	25,3	40	5	GFB35101.0112 ●	GFB35401.0112 ●	GFB35701.0112 ●
2	$\geq M14$	11,6	12	85	28,9	45	5	GFB35101.0114 ●	GFB35401.0114 ●	GFB35701.0114 ●
2,5	$\geq M18$	15	16	100	38,6	48	5	GFB35101.0118 ●	GFB35401.0118 ●	GFB35701.0118 ●
3	$\geq M24$	19,9	20	115	49,4	50	6	GFB35101.0124 ●	GFB35401.0124 ●	GFB35701.0124 ●

TICN



Einsatzgebiete – Material
Applications – material

328

P 1.1-5.1 M 1.1-4.1 K 1.1-4.2
N 1.1-5.2 S 1.1-2.6 H 1.1-2

P mm	$\varnothing D$	$\varnothing d_1$ mm	$\varnothing d_2$	l_1	l_2	l_3	Z	GF-VZ-VHM R15-IKZ-HB TICN	GF-VZ-VHM R15-IKZ-HE TICN	GF-VZ-VHM R15-IKZ-HA TICN
0,5	$\geq M 3$	2,4	6	51	6,2	36	4	GFB35106.0030 ●	GFB35406.0030 ●	GFB35706.0030 ●
0,7	$\geq M 4$	3,15	6	55	8,7	36	4	GFB35106.0040 ●	GFB35406.0040 ●	GFB35706.0040 ●
0,8	$\geq M 5$	4	6	55	10,8	36	4	GFB35106.0050 ●	GFB35406.0050 ●	GFB35706.0050 ●
1	$\geq M 6$	4,8	6	55	12,4	36	4	GFB35106.0060 ●	GFB35406.0060 ●	GFB35706.0060 ●
1,25	$\geq M 8$	6,5	8	63	16,8	36	4	GFB35106.0080 ●	GFB35406.0080 ●	GFB35706.0080 ●
1,5	$\geq M10$	8,2	10	70	21,7	40	5	GFB35106.0100 ●	GFB35406.0100 ●	GFB35706.0100 ●
1,75	$\geq M12$	9,9	10	74	25,3	40	5	GFB35106.0112 ●	GFB35406.0112 ●	GFB35706.0112 ●
2	$\geq M14$	11,6	12	85	28,9	45	5	GFB35106.0114 ●	GFB35406.0114 ●	GFB35706.0114 ●
2,5	$\geq M18$	15	16	100	38,6	48	5	GFB35106.0118 ●	GFB35406.0118 ●	GFB35706.0118 ●
3	$\geq M24$	19,9	20	115	49,4	50	6	GFB35106.0124 ●	GFB35406.0124 ●	GFB35706.0124 ●

Andere Steigungen auf Anfrage
Tools for different thread pitch upon request



- Product Finder
- v_c / f_z
- M
- MF
- UNC
UN, UNS
- UNF
UNEF
- G, Rp
- NPT, NPTF
Rc, W
- BSW, BSF
- Pg
- EG (STI)
SELF-LOCK
- Tr
- Zubehör
Accessories
- Tech. Info
- BGF
- ZBGF
- GSF
- GF
- GF-KEG
- ZGF
- ZIRK-GF
- Gigant
- MoSys



DIN 13

Für Innengewinde
For internal threads

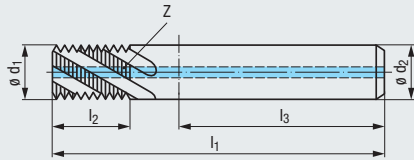

VHM

R15

RH + LH

Z4 - Z5

DIN 6535



Mit höherer Nutenzahl
With increased number of flutes

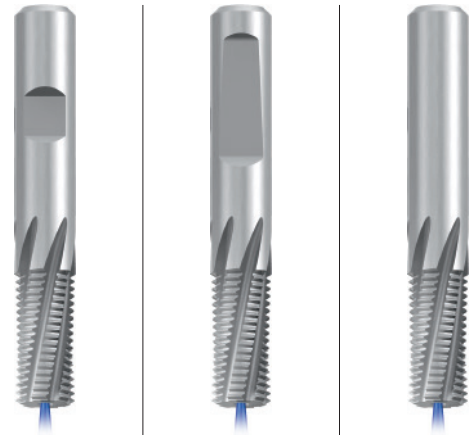

Einsatzgebiete – Material
Applications – material

» 328

P 1.1-5.1 K 1.1-4.2 N 1.1-5, 2.1-6
N 3.1-2 N 4.1-2, 5.2 S 1.1-3

P mm	∅ D	∅ d ₁ mm	∅ d ₂	l ₁	l ₂	l ₃	Z
1	≥ M 8	6,7	8	63	16,4	36	4
1	≥ M10	8,7	10	70	20,4	40	5
1,5	≥ M16	14,1	16	95	33,7	48	5

GF-VZ-VHM R15-IKZ-HB	GF-VZ-VHM R15-IKZ-HE	GF-VZ-VHM R15-IKZ-HA
GFB35101.0251 ●	GFB35401.0251 ●	GFB35701.0251 ●
GFB35101.0276 ●	GFB35401.0276 ●	GFB35701.0276 ●
GFB35101.0359 ●	GFB35401.0359 ●	GFB35701.0359 ●

TICN



Einsatzgebiete – Material
Applications – material

» 328

P 1.1-5.1 M 1.1-4.1 K 1.1-4.2
N 1.1-5.2 S 1.1-2.6 H 1.1-2

P mm	∅ D	∅ d ₁ mm	∅ d ₂	l ₁	l ₂	l ₃	Z
1	≥ M 8	6,7	8	63	16,4	36	4
1	≥ M10	8,7	10	70	20,4	40	5
1,5	≥ M16	14,1	16	95	33,7	48	5

GF-VZ-VHM R15-IKZ-HB TICN	GF-VZ-VHM R15-IKZ-HE TICN	GF-VZ-VHM R15-IKZ-HA TICN
GFB35106.0251 ●	GFB35406.0251 ●	GFB35706.0251 ●
GFB35106.0276 ●	GFB35406.0276 ●	GFB35706.0276 ●
GFB35106.0359 ●	GFB35406.0359 ●	GFB35706.0359 ●

Andere Steigungen auf Anfrage
Tools for different thread pitch upon request

M



DIN 13

Für Innengewinde
For internal threads

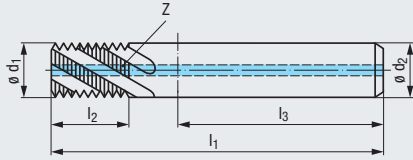

VHM	TICN
R10	RH + LH
Z4 - Z5	DIN 6535 HB HE HA
	$\varnothing D$

Für die Hartbearbeitung
For hard materials

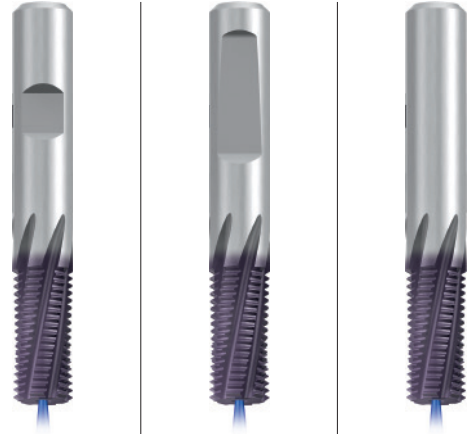

Einsatzgebiete – Material
Applications – material

» 328

N 2.7-8 H 1.3-5

$\varnothing D$ mm	P mm	$\varnothing d_1$ mm	$\varnothing d_2$	l_1	l_2	l_3	Z	GF-H-VHM R10- IKZ -HB TICN	GF-H-VHM R10- IKZ -HE TICN	GF-H-VHM R10- IKZ -HA TICN
M 6	1	4,6	6	55	9,4	36	4	GF927126.0060 ●	GF927426.0060 ●	GF927726.0060 ●
8	1,25	6,25	8	63	13,1	36	5	GF927126.0080 ●	GF927426.0080 ●	GF927726.0080 ●
10	1,5	7,9	8	63	15,7	36	5	GF927126.0100 ●	GF927426.0100 ●	GF927726.0100 ●
12	1,75	9,55	10	70	18,3	40	5	GF927126.0112 ●	GF927426.0112 ●	GF927726.0112 ●
16	2	13,2	14	90	24,9	45	5	GF927126.0116 ●	GF927426.0116 ●	GF927726.0116 ●
20	2,5	15,9	16	100	33,6	48	5	GF927126.0120 ●	GF927426.0120 ●	GF927726.0120 ●

Andere Steigungen auf Anfrage
Tools for different thread pitch upon request

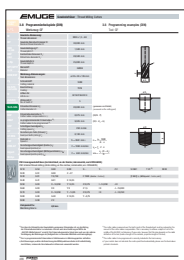

Programmierbeispiel für Gewindefräser
Typ GF siehe Seite 466

Programming example for thread milling
cutters type GF, see page 466

Product Finder

v_c / f_z

M

MF

UNC
UN, UNS

UNF
UNEF

G, Rp

NPT, NPTF
Rc, W

BSW, BSF

Pg

EG (STI)
SELF-LOCK

Tr

Zubehör
Accessories

Tech. Info

BGF

ZBGF

GSF

GF

GF-KEG

ZGF

ZIRK-GF

Gigant

MoSys

Product Finder

v_c / f_z

M

MF

UNC
UN, UNS

UNF
UNEF

G, Rp

NPT, NPTF
Rc, W

BSW, BSF

Pg

EG (STI)
SELF-LOCK

Tr

Zubehör
Accessories

Tech. Info

BGF

ZBGF

GSF

GF

GF-KEG

ZGF

ZIRK-GF

Gigant

MoSys



ASME B1.1

Für Innengewinde
For internal threads

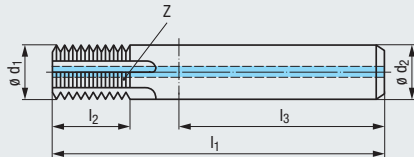

VHM

RH + LH

Z4 - Z5

DIN 6535



Einsatzgebiete – Material
Applications – material

» 328

P 1.1-5.1 K 1.1-4.2 N 1.1-5, 2.1-6
N 3.1-2 N 4.1-2, 5.2 S 1.1-3

P Gg/1" (tpi)	ø D _{min.} inch	ø d ₁ mm	ø d ₂	l ₁	l ₂	l ₃	Z	GF-VHM IKZ-HB	GF-VHM IKZ-HE	GF-VHM IKZ-HA			
24	1/2	9,9	10	70	16,3	40	4	GF163211.9579	●	GF163511.9579	●	GF163811.9579	●
20	1/2	9,9	10	70	17,1	40	4	GF163211.9580	●	GF163511.9580	●	GF163811.9580	●
20	11/16	11,9	12	80	20,9	45	4	GF163121.9580	●	GF163421.9580	●	GF163721.9580	●
20	7/8	15,9	16	90	25,9	48	5	GF163131.9580	●	GF163431.9580	●	GF163731.9580	●
20	1"	19,9	20	105	32,3	50	5	GF163151.9580	●	GF163451.9580	●	GF163751.9580	●
18	1/2	9,9	10	70	17,5	40	4	GF163211.9581	●	GF163511.9581	●	GF163811.9581	●
16	1/2	9,9	10	70	16,6	40	4	GF163211.9582	●	GF163511.9582	●	GF163811.9582	●
16	11/16	11,9	12	80	21,3	45	4	GF163121.9582	●	GF163421.9582	●	GF163721.9582	●
16	7/8	15,9	16	90	26,2	48	5	GF163131.9582	●	GF163431.9582	●	GF163731.9582	●
16	1"	19,9	20	105	32,4	50	5	GF163151.9582	●	GF163451.9582	●	GF163751.9582	●
14	7/8	15,9	16	90	26,2	48	5	GF163131.9583	●	GF163431.9583	●	GF163731.9583	●
12	11/16	11,9	12	80	22,1	45	4	GF163121.9585	●	GF163421.9585	●	GF163721.9585	●
12	7/8	15,9	16	90	26,3	48	5	GF163131.9585	●	GF163431.9585	●	GF163731.9585	●
12	1"	19,9	20	105	32,7	50	5	GF163151.9585	●	GF163451.9585	●	GF163751.9585	●
10	11/16	11,9	12	80	21,4	45	4	GF163121.9587	●	GF163421.9587	●	GF163721.9587	●
9	11/16	11,9	12	80	21	45	4	GF163121.9588	●	GF163421.9588	●	GF163721.9588	●
8	7/8	15,9	16	90	26,8	48	5	GF163131.9589	●	GF163431.9589	●	GF163731.9589	●
8	1"	19,9	20	105	33,2	50	5	GF163151.9589	●	GF163451.9589	●	GF163751.9589	●
6	1"	19,9	20	105	35,8	50	5	GF163151.9591	●	GF163451.9591	●	GF163751.9591	●

TICN



Einsatzgebiete – Material
Applications – material

» 328

P 1.1-5.1 M 1.1-4.1 K 1.1-4.2
N 1.1-5.2 S 1.1-2.6 H 1.1-2

P Gg/1" (tpi)	ø D _{min.} inch	ø d ₁ mm	ø d ₂	l ₁	l ₂	l ₃	Z	GF-VHM IKZ-HB TICN	GF-VHM IKZ-HE TICN	GF-VHM IKZ-HA TICN			
24	1/2	9,9	10	70	16,3	40	4	GF163216.9579	●	GF163516.9579	●	GF163816.9579	●
20	1/2	9,9	10	70	17,1	40	4	GF163216.9580	●	GF163516.9580	●	GF163816.9580	●
20	11/16	11,9	12	80	20,9	45	4	GF163126.9580	●	GF163426.9580	●	GF163726.9580	●
20	7/8	15,9	16	90	25,9	48	5	GF163136.9580	●	GF163436.9580	●	GF163736.9580	●
20	1"	19,9	20	105	32,3	50	5	GF163156.9580	●	GF163456.9580	●	GF163756.9580	●
18	1/2	9,9	10	70	17,5	40	4	GF163216.9581	●	GF163516.9581	●	GF163816.9581	●
16	1/2	9,9	10	70	16,6	40	4	GF163216.9582	●	GF163516.9582	●	GF163816.9582	●
16	11/16	11,9	12	80	21,3	45	4	GF163126.9582	●	GF163426.9582	●	GF163726.9582	●
16	7/8	15,9	16	90	26,2	48	5	GF163136.9582	●	GF163436.9582	●	GF163736.9582	●
16	1"	19,9	20	105	32,4	50	5	GF163156.9582	●	GF163456.9582	●	GF163756.9582	●
14	7/8	15,9	16	90	26,2	48	5	GF163136.9583	●	GF163436.9583	●	GF163736.9583	●
12	11/16	11,9	12	80	22,1	45	4	GF163126.9585	●	GF163426.9585	●	GF163726.9585	●
12	7/8	15,9	16	90	26,3	48	5	GF163136.9585	●	GF163436.9585	●	GF163736.9585	●
12	1"	19,9	20	105	32,7	50	5	GF163156.9585	●	GF163456.9585	●	GF163756.9585	●
10	11/16	11,9	12	80	21,4	45	4	GF163126.9587	●	GF163426.9587	●	GF163726.9587	●
9	11/16	11,9	12	80	21	45	4	GF163126.9588	●	GF163426.9588	●	GF163726.9588	●
8	7/8	15,9	16	90	26,8	48	5	GF163136.9589	●	GF163436.9589	●	GF163736.9589	●
8	1"	19,9	20	105	33,2	50	5	GF163156.9589	●	GF163456.9589	●	GF163756.9589	●
6	1"	19,9	20	105	35,8	50	5	GF163156.9591	●	GF163456.9591	●	GF163756.9591	●

Andere Steigungen auf Anfrage
Tools for different thread pitch upon request



ASME B1.1

Für Innengewinde
For internal threads

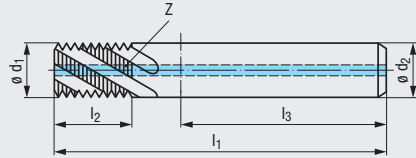

VHM

R30 **RH + LH**

Z4 - Z5 **DIN 6535**
 HB
 HE
 HA

$\varnothing D$

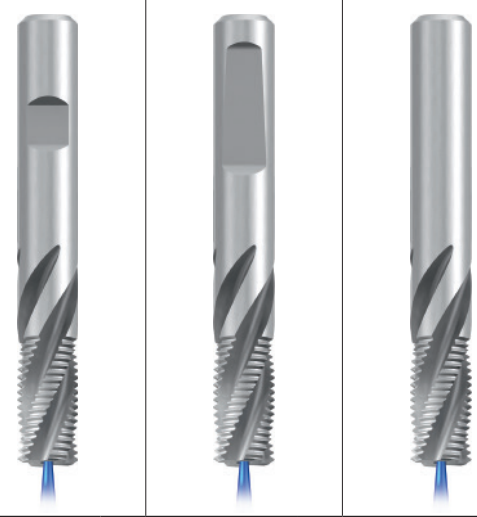

Einsatzgebiete – Material
Applications – material

» 328

P 1.1-3.1 **K** 1.1-4.2 **N** 1.1-5
N 2.1-6 **N** 3.1-4.2, 5.2 **S** 1.1-2

P Gg/1" (tpi)	$\varnothing D_{min.}$ inch	$\varnothing d_1$ mm	$\varnothing d_2$	l_1	l_2	l_3	Z	GF-VHM					
								R30-Ig-IKZ-HB	R30-Ig-IKZ-HE	R30-Ig-IKZ-HA			
24	1/2	9,9	10	80	20,6	40	4	GF162311.9579	●	GF162611.9579	●	GF162911.9579	●
20	1/2	9,9	10	80	20,9	40	4	GF162311.9580	●	GF162611.9580	●	GF162911.9580	●
20	11/16	11,9	12	90	26	45	4	GF162321.9580	●	GF162621.9580	●	GF162921.9580	●
20	7/8	15,9	16	100	32,3	48	5	GF162331.9580	●	GF162631.9580	●	GF162931.9580	●
20	1"	19,9	20	115	41,2	50	5	GF162351.9580	●	GF162651.9580	●	GF162951.9580	●
18	1/2	9,9	10	80	20,4	40	4	GF162311.9581	●	GF162611.9581	●	GF162911.9581	●
16	1/2	9,9	10	80	21,3	40	4	GF162311.9582	●	GF162611.9582	●	GF162911.9582	●
16	11/16	11,9	12	90	26,1	45	4	GF162321.9582	●	GF162621.9582	●	GF162921.9582	●
16	7/8	15,9	16	100	32,4	48	5	GF162331.9582	●	GF162631.9582	●	GF162931.9582	●
16	1"	19,9	20	115	40,4	50	5	GF162351.9582	●	GF162651.9582	●	GF162951.9582	●
14	7/8	15,9	16	100	33,4	48	5	GF162331.9583	●	GF162631.9583	●	GF162931.9583	●
12	11/16	11,9	12	90	26,3	45	4	GF162321.9585	●	GF162621.9585	●	GF162921.9585	●
12	7/8	15,9	16	100	32,7	48	5	GF162331.9585	●	GF162631.9585	●	GF162931.9585	●
12	1"	19,9	20	115	41,1	50	5	GF162351.9585	●	GF162651.9585	●	GF162951.9585	●
10	11/16	11,9	12	90	26,5	45	4	GF162321.9587	●	GF162621.9587	●	GF162921.9587	●
9	11/16	11,9	12	90	26,6	45	4	GF162321.9588	●	GF162621.9588	●	GF162921.9588	●
8	7/8	15,9	16	100	33,1	48	5	GF162331.9589	●	GF162631.9589	●	GF162931.9589	●
8	1"	19,9	20	115	42,7	50	5	GF162351.9589	●	GF162651.9589	●	GF162951.9589	●
6	1"	19,9	20	115	44,3	50	5	GF162351.9591	●	GF162651.9591	●	GF162951.9591	●

TICN



Einsatzgebiete – Material
Applications – material

» 328

P 1.1-3.1 **M** 1.1-2.1 **K** 1.1-4.2
N 1.1-2.7 **N** 3.1-5.2 **S** 1.1-2, 2.1

P Gg/1" (tpi)	$\varnothing D_{min.}$ inch	$\varnothing d_1$ mm	$\varnothing d_2$	l_1	l_2	l_3	Z	GF-VHM					
								R30-Ig-IKZ-HB TICN	R30-Ig-IKZ-HE TICN	R30-Ig-IKZ-HA TICN			
24	1/2	9,9	10	80	20,6	40	4	GF162316.9579	●	GF162616.9579	●	GF162916.9579	●
20	1/2	9,9	10	80	20,9	40	4	GF162316.9580	●	GF162616.9580	●	GF162916.9580	●
20	11/16	11,9	12	90	26	45	4	GF162326.9580	●	GF162626.9580	●	GF162926.9580	●
20	7/8	15,9	16	100	32,3	48	5	GF162336.9580	●	GF162636.9580	●	GF162936.9580	●
20	1"	19,9	20	115	41,2	50	5	GF162356.9580	●	GF162656.9580	●	GF162956.9580	●
18	1/2	9,9	10	80	20,4	40	4	GF162316.9581	●	GF162616.9581	●	GF162916.9581	●
16	1/2	9,9	10	80	21,3	40	4	GF162316.9582	●	GF162616.9582	●	GF162916.9582	●
16	11/16	11,9	12	90	26,1	45	4	GF162326.9582	●	GF162626.9582	●	GF162926.9582	●
16	7/8	15,9	16	100	32,4	48	5	GF162336.9582	●	GF162636.9582	●	GF162936.9582	●
16	1"	19,9	20	115	40,4	50	5	GF162356.9582	●	GF162656.9582	●	GF162956.9582	●
14	7/8	15,9	16	100	33,4	48	5	GF162336.9583	●	GF162636.9583	●	GF162936.9583	●
12	11/16	11,9	12	90	26,3	45	4	GF162326.9585	●	GF162626.9585	●	GF162926.9585	●
12	7/8	15,9	16	100	32,7	48	5	GF162336.9585	●	GF162636.9585	●	GF162936.9585	●
12	1"	19,9	20	115	41,1	50	5	GF162356.9585	●	GF162656.9585	●	GF162956.9585	●
10	11/16	11,9	12	90	26,5	45	4	GF162326.9587	●	GF162626.9587	●	GF162926.9587	●
9	11/16	11,9	12	90	26,6	45	4	GF162326.9588	●	GF162626.9588	●	GF162926.9588	●
8	7/8	15,9	16	100	33,1	48	5	GF162336.9589	●	GF162636.9589	●	GF162936.9589	●
8	1"	19,9	20	115	42,7	50	5	GF162356.9589	●	GF162656.9589	●	GF162956.9589	●
6	1"	19,9	20	115	44,3	50	5	GF162356.9591	●	GF162656.9591	●	GF162956.9591	●

Andere Steigungen auf Anfrage
Tools for different thread pitch upon request

- Product Finder
- v_c / f_z
- M
- MF
- UNC
UN, UNS
- UNF
UNEF
- G, Rp
- NPT, NPTF
Rc, W
- BSW, BSF
- Pg
- EG (STI)
SELF-LOCK
- Tr
- Zubehör
Accessories
- Tech. Info
- BGF
- ZBGF
- GSF
- GF

UNC, UN

ASME B1.1

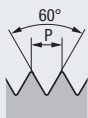

Für Innengewinde
For internal threads

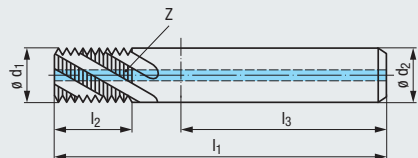

VHM **TICN**

R15 **RH + LH**

Z4 - Z6 **DIN 6535**
HB
HE
HA

Mit höherer Nutenzahl
With increased number of flutes

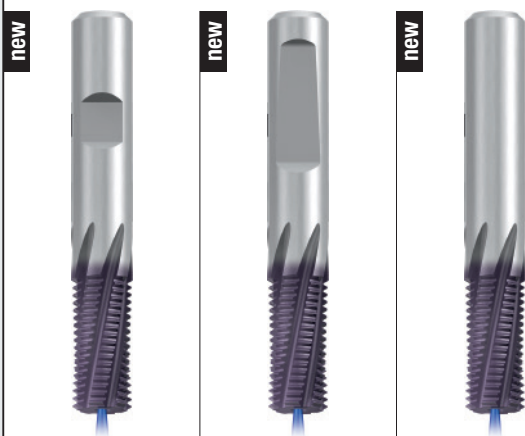

Einsatzgebiete – Material
Applications – material [» 328](#)

P 1.1-5.1 **M** 1.1-4.1 **K** 1.1-4.2
N 1.1-5.2 **S** 1.1-2.6 **H** 1.1-2

P Gg/1" (tpi)	$\varnothing D_{min.}$ inch	$\varnothing d_1$ mm	$\varnothing d_2$	l_1	l_2	l_3	Z	GF-VZ-VHM R15-IKZ-HB TICN	GF-VZ-VHM R15-IKZ-HE TICN	GF-VZ-VHM R15-IKZ-HA TICN
24	\geq Nr. 10	3,7	6	55	10	36	4	GFB35106.5007	● GFB35406.5007	● GFB35706.5007
20	\geq 1/4	4,95	6	58	13,3	36	4	GFB35106.5009	● GFB35406.5009	● GFB35706.5009
18	\geq 5/16	6,3	8	62	16,2	36	4	GFB35106.5010	● GFB35406.5010	● GFB35706.5010
16	\geq 3/8	7,65	8	65	19,8	36	5	GFB35106.5011	● GFB35406.5011	● GFB35706.5011
14	\geq 7/16	9	10	74	22,6	40	5	GFB35106.5012	● GFB35406.5012	● GFB35706.5012
13	\geq 1/2	10,4	12	80	26,3	45	5	GFB35106.5013	● GFB35406.5013	● GFB35706.5013
12	\geq 9/16	11,8	12	85	30,6	45	5	GFB35106.5014	● GFB35406.5014	● GFB35706.5014
11	\geq 5/8	13	14	90	33,4	45	5	GFB35106.5015	● GFB35406.5015	● GFB35706.5015
10	\geq 3/4	15,9	16	100	39,3	48	5	GFB35106.5016	● GFB35406.5016	● GFB35706.5016
9	\geq 7/8	18,9	20	110	46,5	50	6	GFB35106.5017	● GFB35406.5017	● GFB35706.5017
8	\geq 1"	21,6	25	125	52,3	56	6	GFB35106.5018	● GFB35406.5018	● GFB35706.5018

Andere Steigungen auf Anfrage
Tools for different thread pitch upon request

- ZIRK-GF
- Gigant
- MoSys
- GF-KEG
- ZGF

UNF, UN

ASME B1.1

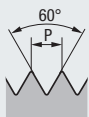

Für Innengewinde
For internal threads

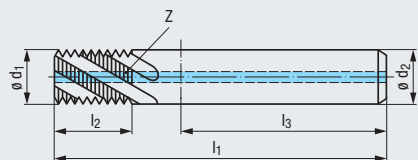

VHM **TICN**

R15 **RH + LH**

Z4 - Z8 **DIN 6535**
HB
HE
HA

Mit höherer Nutenzahl
With increased number of flutes

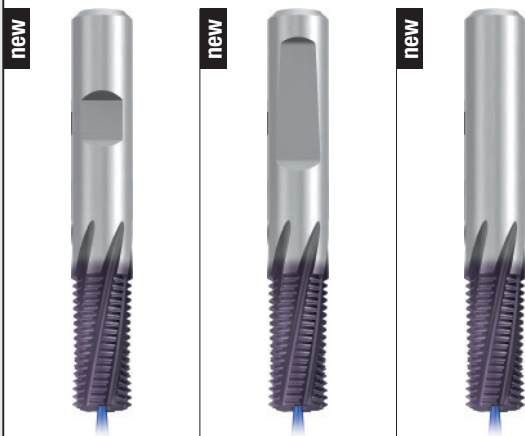

Einsatzgebiete – Material
Applications – material [» 328](#)

P 1.1-5.1 **M** 1.1-4.1 **K** 1.1-4.2
N 1.1-5.2 **S** 1.1-2.6 **H** 1.1-2

P Gg/1" (tpi)	$\varnothing D_{min.}$ inch	$\varnothing d_1$ mm	$\varnothing d_2$	l_1	l_2	l_3	Z	GF-VZ-VHM R15-IKZ-HB TICN	GF-VZ-VHM R15-IKZ-HE TICN	GF-VZ-VHM R15-IKZ-HA TICN
32	\geq Nr. 10	3,9	6	55	9,9	36	4	GFB35106.5041	● GFB35406.5041	● GFB35706.5041
28	\geq Nr. 12	4,45	6	58	11,3	36	4	GFB35106.5042	● GFB35406.5042	● GFB35706.5042
28	\geq 1/4	5,3	6	58	13,1	36	4	GFB35106.5043	● GFB35406.5043	● GFB35706.5043
24	\geq 5/16	6,6	8	62	16,4	36	5	GFB35106.5044	● GFB35406.5044	● GFB35706.5044
20	\geq 7/16	9,55	10	74	22,2	40	6	GFB35106.5046	● GFB35406.5046	● GFB35706.5046
18	\geq 9/16	12,5	14	85	28,9	45	7	GFB35106.5048	● GFB35406.5048	● GFB35706.5048
16	\geq 3/4	17	18	102	38,8	48	8	GFB35106.5050	● GFB35406.5050	● GFB35706.5050

Andere Steigungen auf Anfrage
Tools for different thread pitch upon request

G (BSP), Rp (BSPP), W

DIN EN ISO 228, DIN EN 10226-1, ISO 7/1, BS 84



VHM

RH + LH

Z4 - Z5



DIN 6535



Für Innen- und Außengewinde
For internal and external threads

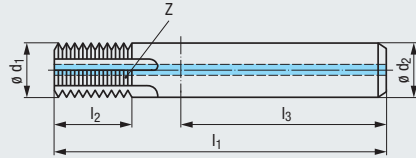

Einsatzgebiete – Material
Applications – material

» 328

P 1.1-5.1 K 1.1-4.2 N 1.1-5, 2.1-6
N 3.1-2 N 4.1-2, 5.2 S 1.1-3

P Gg/1" (tpi)	$\varnothing D_{min.}^{1)}$ inch	$\varnothing d_1$ mm	$\varnothing d_2$	l_1	l_2	l_3	Z	GF-VHM IKZ-HB	GF-VHM IKZ-HE	GF-VHM IKZ-HA
19	1/4	9,9	10	70	16,7	40	4	GF163211.9545 ●	GF163511.9545 ●	GF163811.9545 ●
14	1/2	15,9	16	90	26,3	48	5	GF163131.9548 ●	GF163431.9548 ●	GF163731.9548 ●
14	3/4	19,9	20	105	33,5	50	5	GF163151.9548 ●	GF163451.9548 ●	GF163751.9548 ●
11	1"	15,9	16	90	26,5	48	5	GF163131.9550 ●	GF163431.9550 ●	GF163731.9550 ●
11	1"	19,9	20	105	33,5	50	5	GF163151.9550 ●	GF163451.9550 ●	GF163751.9550 ●

TICN



Einsatzgebiete – Material
Applications – material

» 328

P 1.1-5.1 M 1.1-4.1 K 1.1-4.2
N 1.1-5.2 S 1.1-2.6 H 1.1-2

P Gg/1" (tpi)	$\varnothing D_{min.}^{1)}$ inch	$\varnothing d_1$ mm	$\varnothing d_2$	l_1	l_2	l_3	Z	GF-VHM IKZ-HB TICN	GF-VHM IKZ-HE TICN	GF-VHM IKZ-HA TICN
19	1/4	9,9	10	70	16,7	40	4	GF163216.9545 ●	GF163516.9545 ●	GF163816.9545 ●
14	1/2	15,9	16	90	26,3	48	5	GF163136.9548 ●	GF163436.9548 ●	GF163736.9548 ●
14	3/4	19,9	20	105	33,5	50	5	GF163156.9548 ●	GF163456.9548 ●	GF163756.9548 ●
11	1"	15,9	16	90	26,5	48	5	GF163136.9550 ●	GF163436.9550 ●	GF163736.9550 ●
11	1"	19,9	20	105	33,5	50	5	GF163156.9550 ●	GF163456.9550 ●	GF163756.9550 ●

¹⁾ Durchmesser bezogen auf Rohr-Innengewinde bzw. Rohr-Außengewinde
Diameter related to internal pipe thread resp. external pipe thread

Product Finder

v_c / f_z

M

MF

UNC
UN, UNS

UNF
UNEF

G, Rp

NPT, NPTF
Rc, W

BSW, BSF

Pg

EG (STI)
SELF-LOCK

Tr

Zubehör
Accessories

Tech. Info

BGF

ZBGF

GSF

GF

GF-KEG

ZGF

ZIRK-GF

Gigant

MoSys

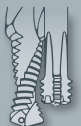

- Product Finder
- v_c / f_z
- M
- MF
- UNC UN, UNS
- UNF UNEF
- G, Rp
- NPT, NPTF Rp, W
- BSW, BSF
- Pg
- EG (STI) SELF-LOCK
- Tr
- Zubehör Accessories
- Tech. Info
- BGF
- ZBGF
- GSF
- GF
- GF-KEG
- ZGF
- ZIRK-GF
- Gigant
- MoSys

G (BSP), Rp (BSPP), W

DIN EN ISO 228, DIN EN 10226-1, ISO 7/1, BS 84

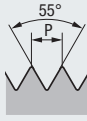

VHM

R30

RH + LH

Z4 - Z5



DIN 6535



Für Innen- und Außengewinde
For internal and external threads

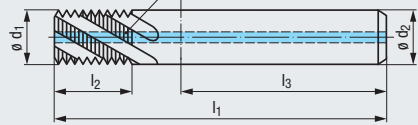

Einsatzgebiete – Material
Applications – material

» 328

P 1.1-3.1 K 1.1-4.2 N 1.1-5
N 2.1-6 N 3.1-4.2, 5.2 S 1.1-2

P Gg/1" (tpi)	$\varnothing D_{\min.}^{1)}$ inch	$\varnothing d_1$ mm	$\varnothing d_2$	l_1	l_2	l_3	Z	GF-VHM R30-IKZ-HB	GF-VHM R30-IKZ-HE	GF-VHM R30-IKZ-HA
19	1/4	9,9	10	70	16,7	40	4	GF162211.9545	● GF162511.9545	● GF162811.9545
14	1/2	11,9	12	80	20,9	45	4	GF162121.9548	● GF162421.9548	● GF162721.9548
14	1/2	15,9	16	90	26,3	48	5	GF162131.9548	● GF162431.9548	● GF162731.9548
14	3/4	19,9	20	105	33,5	50	5	GF162151.9548	● GF162451.9548	● GF162751.9548
11	1"	15,9	16	90	26,5	48	5	GF162131.9550	● GF162431.9550	● GF162731.9550
11	1"	19,9	20	105	33,5	50	5	GF162151.9550	● GF162451.9550	● GF162751.9550

TICN



Einsatzgebiete – Material
Applications – material

» 328

P 1.1-3.1 M 1.1-2.1 K 1.1-4.2
N 1.1-2.7 N 3.1-5.2 S 1.1-2, 2.1

P Gg/1" (tpi)	$\varnothing D_{\min.}^{1)}$ inch	$\varnothing d_1$ mm	$\varnothing d_2$	l_1	l_2	l_3	Z	GF-VHM R30-IKZ-HB TICN	GF-VHM R30-IKZ-HE TICN	GF-VHM R30-IKZ-HA TICN
19	1/4	9,9	10	70	16,7	40	4	GF162216.9545	● GF162516.9545	● GF162816.9545
14	1/2	11,9	12	80	20,9	45	4	GF162126.9548	● GF162426.9548	● GF162726.9548
14	1/2	15,9	16	90	26,3	48	5	GF162136.9548	● GF162436.9548	● GF162736.9548
14	3/4	19,9	20	105	33,5	50	5	GF162156.9548	● GF162456.9548	● GF162756.9548
11	1"	15,9	16	90	26,5	48	5	GF162136.9550	● GF162436.9550	● GF162736.9550
11	1"	19,9	20	105	33,5	50	5	GF162156.9550	● GF162456.9550	● GF162756.9550

¹⁾ Durchmesser bezogen auf Rohr-Innengewinde bzw. Rohr-Außengewinde
Diameter related to internal pipe thread resp. external pipe thread

G (BSP), Rp (BSPP), W

DIN EN ISO 228, DIN EN 10226-1, ISO 7/1, BS 84



Für Innengewinde
For internal threads

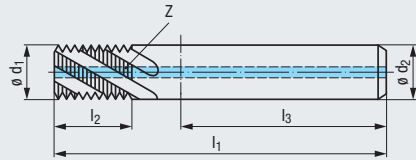

VHM

R15

RH + LH

Z5 - Z8



DIN 6535



Mit höherer Nutenzahl
With increased number of flutes

new



new



new



Einsatzgebiete – Material
Applications – material

» 328

P 1.1-5.1 K 1.1-4.2 N 1.1-5, 2.1-6
N 3.1-2 N 4.1-2, 5.2 S 1.1-3

P mm	$\varnothing D_{min.}$ mm	$\varnothing d_1$ mm	$\varnothing d_2$	l_1	l_2	l_3	Z	GF-Z-VHM R15-IKZ-HB	GF-Z-VHM R15-IKZ-HE	GF-Z-VHM R15-IKZ-HA
19	G 1/4	9,9	10	70	20,7	40	6	GF165361.9545 ●	GF165661.9545 ●	GF165961.9545 ●
14	G 1/2	11,9	12	80	26,3	45	5	GF165371.9548 ●	GF165671.9548 ●	GF165971.9548 ●
14	G 1/2	15,9	16	90	33,6	48	6	GF165381.9548 ●	GF165681.9548 ●	GF165981.9548 ●
14	G 3/4	19,9	20	105	40,8	50	8	GF165391.9548 ○	GF165691.9548 ○	GF165991.9548 ○
11	G 1"	15,9	16	90	33,5	48	5	GF165381.9550 ●	GF165681.9550 ●	GF165981.9550 ●
11	G 1"	19,9	20	105	42,7	50	6	GF165391.9550 ●	GF165691.9550 ●	GF165991.9550 ●

TICN

new



new



new



Einsatzgebiete – Material
Applications – material

» 328

P 1.1-5.1 M 1.1-4.1 K 1.1-4.2
N 1.1-5.2 S 1.1-2.6 H 1.1-2

P mm	$\varnothing D_{min.}$ mm	$\varnothing d_1$ mm	$\varnothing d_2$	l_1	l_2	l_3	Z	GF-Z-VHM R15-IKZ-HB TICN	GF-Z-VHM R15-IKZ-HE TICN	GF-Z-VHM R15-IKZ-HA TICN
19	G 1/4	9,9	10	70	20,7	40	6	GF165366.9545 ●	GF165666.9545 ●	GF165966.9545 ●
14	G 1/2	11,9	12	80	26,3	45	5	GF165376.9548 ●	GF165676.9548 ●	GF165976.9548 ●
14	G 1/2	15,9	16	90	33,6	48	6	GF165386.9548 ●	GF165686.9548 ●	GF165986.9548 ●
14	G 3/4	19,9	20	105	40,8	50	8	GF165396.9548 ○	GF165696.9548 ○	GF165996.9548 ○
11	G 1"	15,9	16	90	33,5	48	5	GF165386.9550 ●	GF165686.9550 ●	GF165986.9550 ●
11	G 1"	19,9	20	105	42,7	50	6	GF165396.9550 ●	GF165696.9550 ●	GF165996.9550 ●

Andere Steigungen auf Anfrage
Tools for different thread pitch upon request

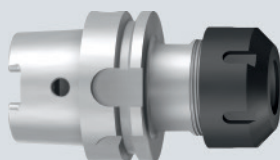

Spannzangen-Aufnahmen
Typ KSN/Synchro
siehe Seite 711 - 713

Collet holders
type KSN/Synchro,
see page 711 - 713



Product Finder

v_c / f_z

M

MF

UNC
UN, UNS

UNF
UNEF

G, Rp

NPT, NPTF
Rc, W

BSW, BSF

Pg

EG (STI)
SELF-LOCK

Tr

Zubehör
Accessories

Tech. Info

BGF

ZBGF

GSF

GF

GF-KEG

ZGF

ZIRK-GF

Gigant

MoSys



Pg

DIN 40430

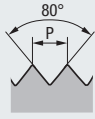

VHM

RH + LH

Z4



DIN 6535



Für Innen- und Außengewinde
For internal and external threads

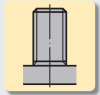
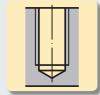
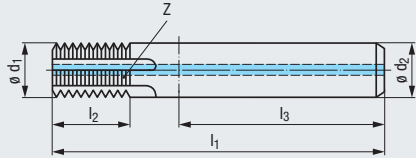

Einsatzgebiete – Material
Applications – material

» 328

P 1.1-5.1 K 1.1-4.2 N 1.1-5, 2.1-6
N 3.1-2 N 4.1-2, 5.2 S 1.1-3

Nenngröße

Nom. size

ϕD 1)

P

Gg/1" (tpi)

ϕd_1

mm

ϕd_2

mm

l_1

mm

l_2

mm

l_3

mm

Z

Nenngröße Nom. size ϕD 1)	P Gg/1" (tpi)	ϕd_1 mm	ϕd_2 mm	l_1 mm	l_2 mm	l_3 mm	Z
Pg 7	20	9,9	10	70	17,1	40	4
9	18	11,9	12	80	20,5	45	4
21	16	11,9	12	80	21,4	45	4

GF-VHM
IKZ-HB

GF-VHM
IKZ-HE

GF-VHM
IKZ-HA

GF163211.9661
GF163121.9662
GF163121.9663

● GF163511.9661
● GF163421.9662
● GF163421.9663

● GF163811.9661
● GF163721.9662
● GF163721.9663

TICN



Einsatzgebiete – Material
Applications – material

» 328

P 1.1-5.1 M 1.1-4.1 K 1.1-4.2
N 1.1-5.2 S 1.1-2.6 H 1.1-2

Nenngröße

Nom. size

ϕD 1)

P

Gg/1" (tpi)

ϕd_1

mm

ϕd_2

mm

l_1

mm

l_2

mm

l_3

mm

Z

Nenngröße Nom. size ϕD 1)	P Gg/1" (tpi)	ϕd_1 mm	ϕd_2 mm	l_1 mm	l_2 mm	l_3 mm	Z
Pg 7	20	9,9	10	70	17,1	40	4
9	18	11,9	12	80	20,5	45	4
21	16	11,9	12	80	21,4	45	4

GF163216.9661
GF163126.9662
GF163126.9663

● GF163516.9661
● GF163426.9662
● GF163426.9663

● GF163816.9661
● GF163726.9662
● GF163726.9663

1) Durchmesser bezogen auf Rohr-Innengewinde bzw. Rohr-Außengewinde
Diameter related to internal pipe thread resp. external pipe thread

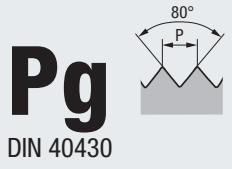

Pg
DIN 40430

VHM

R30 RH + LH

Z4 **DIN 6535**
HB
HE
HA

Ø D Ø D

Ø D

Für Innen- und Außengewinde
For internal and external threads

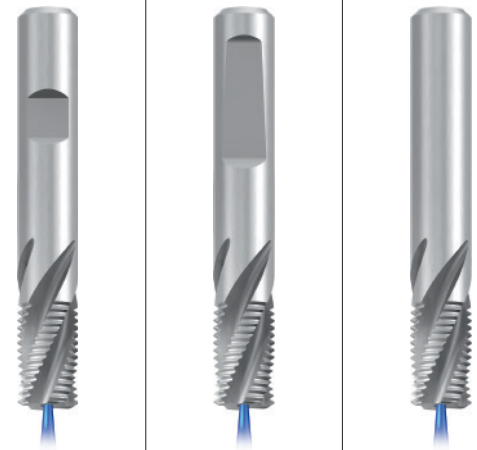
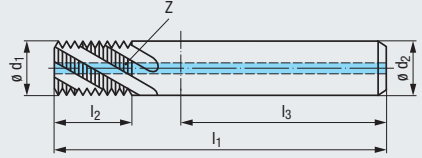

Einsatzgebiete – Material
Applications – material

P 1.1-3.1 K 1.1-4.2 N 1.1-5
N 2.1-6 N 3.1-4.2, 5.2 S 1.1-2

Nenngröße Nom. size Ø D ¹⁾	P Gg/1" (tpi)	Ø d ₁ mm	Ø d ₂	l ₁	l ₂	l ₃	Z						
								GF-VHM R30-1KZ-HB	GF-VHM R30-1KZ-HE	GF-VHM R30-1KZ-HA			
Pg 7	20	9,9	10	70	17,1	40	4	GF162211.9661	●	GF162511.9661	●	GF162811.9661	●
9	18	11,9	12	80	20,5	45	4	GF162121.9662	●	GF162421.9662	●	GF162721.9662	●
21	16	11,9	12	80	21,4	45	4	GF162121.9663	●	GF162421.9663	●	GF162721.9663	●

Einsatzgebiete – Material
Applications – material

P 1.1-3.1 M 1.1-2.1 K 1.1-4.2
N 1.1-2.7 N 3.1-5.2 S 1.1-2, 2.1

Nenngröße Nom. size Ø D ¹⁾	P Gg/1" (tpi)	Ø d ₁ mm	Ø d ₂	l ₁	l ₂	l ₃	Z						
								GF-VHM R30-1KZ-HB TICN	GF-VHM R30-1KZ-HE TICN	GF-VHM R30-1KZ-HA TICN			
Pg 7	20	9,9	10	70	17,1	40	4	GF162216.9661	●	GF162516.9661	●	GF162816.9661	●
9	18	11,9	12	80	20,5	45	4	GF162126.9662	●	GF162426.9662	●	GF162726.9662	●
21	16	11,9	12	80	21,4	45	4	GF162126.9663	●	GF162426.9663	●	GF162726.9663	●

¹⁾ Durchmesser bezogen auf Rohr-Innengewinde bzw. Rohr-Außengewinde
Diameter related to internal pipe thread resp. external pipe thread

- Product Finder
- v_c / f_z
- M
- MF
- UNC UN, UNS
- UNF UNEF
- G, Rp
- NPT, NPTF Rc, W
- BSW, BSF
- Pg
- EG (STI) SELF-LOCK
- Tr
- Zubehör Accessories
- Tech. Info
- BGF
- ZBGF
- GSF
- GF
- GF-KEG
- ZGF
- ZIRK-GF
- Gigant
- MoSys



Product Finder

 v_c / f_z

M

MF

 UNC
UN, UNS

 UNF
UNEF

G, Rp

 NPT, NPTF
Rc, W

BSW, BSF

Pg

 EG (STI)
SELF-LOCK

Tr

 Zubehör
Accessories

Tech. Info

BGF

ZBGF

GSF

GF

GF-KEG

ZGF

ZIRK-GF

Gigant

MoSys

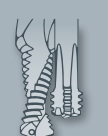

LK-M

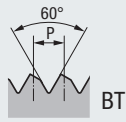

EMUGE-Norm · EMUGE Standard

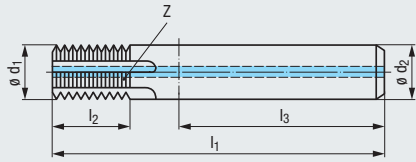
Für Innengewinde
For internal threads

VHM
RH + LH
Z4 - Z5

DIN 6535

 $\varnothing D$

 Einsatzgebiete – Material
Applications – material

» 328

P 1.1-5.1	K 1.1-4.2	N 1.1-5, 2.1-6
N 3.1-2	N 4.1-2, 5.2	S 1.1-3

GF-VHM
IKZ-HB
GF-VHM
IKZ-HE
GF-VHM
IKZ-HA

P mm	$\varnothing D_{min.}$ mm	$\varnothing d_1$ mm	$\varnothing d_2$	l_1	l_2	l_3	Z	GF-VHM IKZ-HB	GF-VHM IKZ-HE	GF-VHM IKZ-HA
1	14	9,9	10	70	16,4	40	4	GF163211.9757	● GF163511.9757	● GF163811.9757
1	16	11,9	12	80	20,4	45	4	GF163121.9757	● GF163421.9757	● GF163721.9757
1,5	14	9,9	10	70	17	40	4	GF163211.9664	● GF163511.9664	● GF163811.9664
1,5	16	11,9	12	80	21,5	45	4	GF163121.9664	● GF163421.9664	● GF163721.9664
2	22	15,9	16	90	26,7	48	5	GF163131.9705	● GF163431.9705	● GF163731.9705
3	30	19,9	20	105	34,1	50	5	GF163151.9767	● GF163451.9767	● GF163751.9767

TICN

 Einsatzgebiete – Material
Applications – material

» 328

P 1.1-5.1	M 1.1-4.1	K 1.1-4.2
N 1.1-5.2	S 1.1-2.6	H 1.1-2

GF-VHM
IKZ-HB
TICN
GF-VHM
IKZ-HE
TICN
GF-VHM
IKZ-HA
TICN

P mm	$\varnothing D_{min.}$ mm	$\varnothing d_1$ mm	$\varnothing d_2$	l_1	l_2	l_3	Z	GF-VHM IKZ-HB TICN	GF-VHM IKZ-HE TICN	GF-VHM IKZ-HA TICN
1	14	9,9	10	70	16,4	40	4	GF163216.9757	● GF163516.9757	● GF163816.9757
1	16	11,9	12	80	20,4	45	4	GF163126.9757	● GF163426.9757	● GF163726.9757
1,5	14	9,9	10	70	17	40	4	GF163216.9664	● GF163516.9664	● GF163816.9664
1,5	16	11,9	12	80	21,5	45	4	GF163126.9664	● GF163426.9664	● GF163726.9664
2	22	15,9	16	90	26,7	48	5	GF163136.9705	● GF163436.9705	● GF163736.9705
3	30	19,9	20	105	34,1	50	5	GF163156.9767	● GF163456.9767	● GF163756.9767

 Andere Steigungen auf Anfrage
Tools for different thread pitch upon request

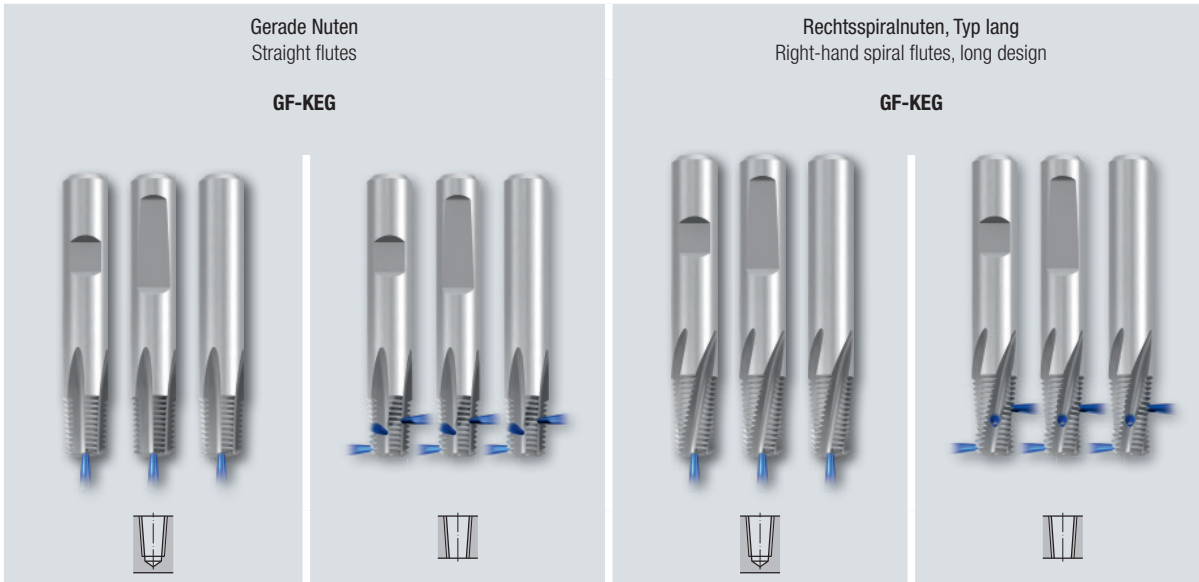

Seite · Page

401	402	403	404	NPT (API-LP)
406	407	408	409	NPTF
411	412			Rc (BSPT)

Product Finder

v_c / f_z

M

MF

UNC
UN, UNS

UNF
UNEF

G, Rp

NPT, NPTF
Rc, W

BSW, BSF

Pg

EG (STI)
SELF-LOCK

Tr

Zubehör
Accessories

Tech. Info

BGF

ZBGF

GSF

GF

GF-KEG

ZGF

ZIRK-GF

Gigant

MoSys



Mögliche Modifikationen · Possible modifications



Stirrfase ohne/mit Stirnschnitt
Face chamfer with/without cutting face



AZR/AZ (ausgesetzte Zähne)
AZR/AZ (alternating teeth)



Unvollständigen Gang entfernen
Remove incomplete thread



IKZN (innere Kühlschmierstoff-Zufuhr mit Austritt in den Nuten)
IKZN (internal coolant supply exiting in the flutes)



Halsfreischliff
Recessed neck



Schaftkühlfluten
Coolant grooves along the shank

Eine Beschreibung dieser Modifikationsmöglichkeiten finden Sie auf Seite 456 - 457
For a description of these modifications, see pages 456 - 457

Gewindefräszyklus · Thread milling cycle

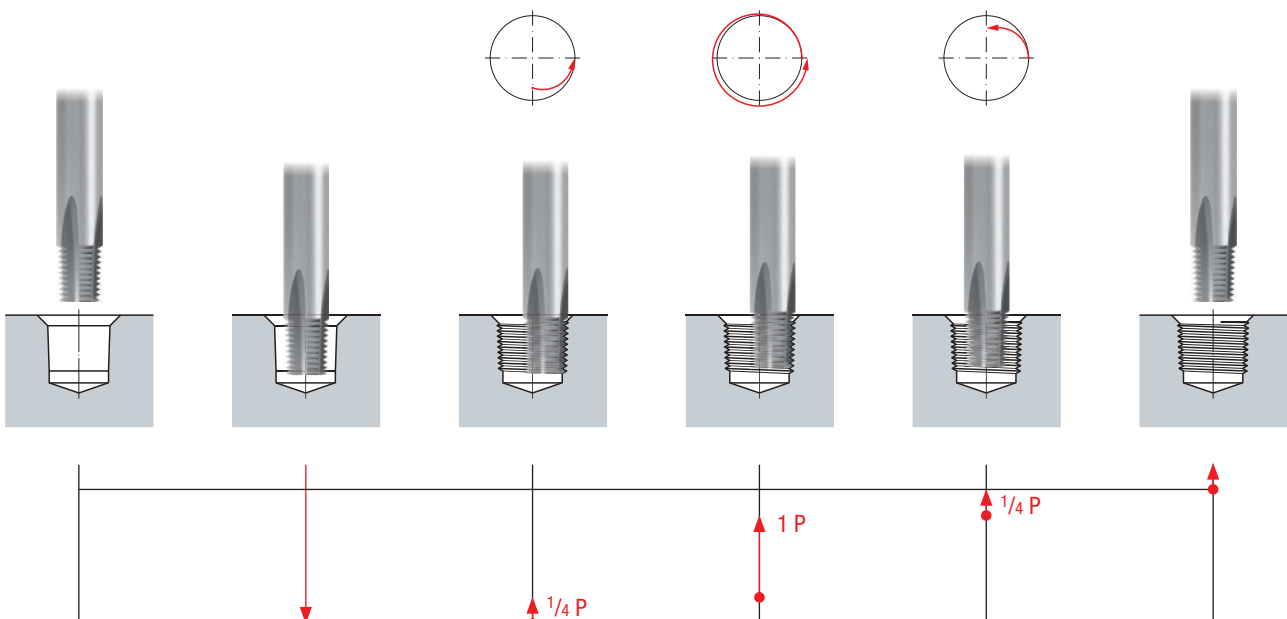

Product Finder

v_c / f_z

M

MF

UNC
UN, UNS

UNF
UNEF

G, Rp

NPT, NPTF
Rc, W

BSW, BSF

Pg

EG (STI)
SELF-LOCK

Tr

Zubehör
Accessories

Tech. Info

BGF

ZBGF

GSF

GF

GF-KEG

ZGF

ZIRK-GF

Gigant

MoSys



NPT

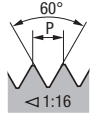

ANSI/ASME B1.20.1

a) Zylindrisch vorarbeiten
Cylindrical preparation of thread hole

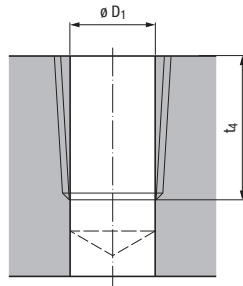

EMUGE NPT-Gewidefräser sind für die Lochformen a) und b) geeignet.
EMUGE NPT thread milling cutters are suited for the hole forms a) and b).

Nenngröße Nom. size D	P Gg/1" (tpi)	$\varnothing D_1$	t_4
1/16	27	6,15	8,30
1/8	27	8,50	8,30
1/4	18	11,00	12,15
3/8	18	14,40	12,45
1/2	14	17,80	16,30
3/4	14	23,15	16,30
1"	11 1/2	29,05	19,55
1 1/4	11 1/2	37,80	20,05
1 1/2	11 1/2	43,85	20,05
2"	11 1/2	55,85	20,45

b) Kegelig vorarbeiten
Tapered preparation of thread hole

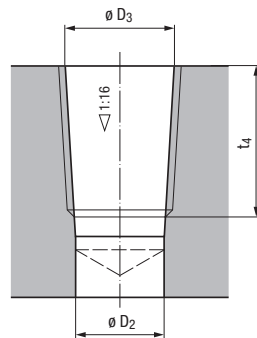

Nenngröße Nom. size D	P Gg/1" (tpi)	$\varnothing D_2$	$\varnothing D_3$ +0,05	t_4
1/16	27	5,95	6,39	8,30
1/8	27	8,30	8,74	8,30
1/4	18	10,75	11,36	12,15
3/8	18	14,15	14,80	12,45
1/2	14	17,45	18,32	16,30
3/4	14	22,80	23,67	16,30
1"	11 1/2	28,65	29,69	19,55
1 1/4	11 1/2	37,35	38,45	20,05
1 1/2	11 1/2	43,45	44,52	20,05
2"	11 1/2	55,45	56,56	20,45

NPT



ANSI/ASME B1.20.1

Für kegeliges Innengewinde
For internal tapered threads

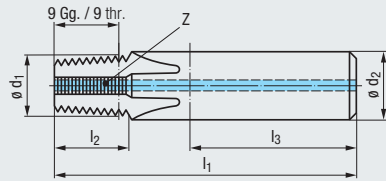

VHM

RH + LH

Z3 - Z5



DIN 6535

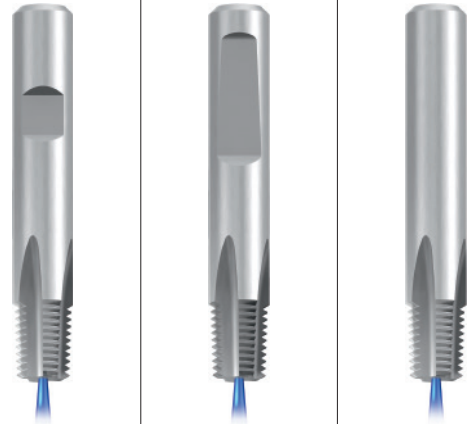

Einsatzgebiete – Material
Applications – material

P 1.1-5.1 K 1.1-4.2 N 1.1-5, 2.1-6
N 3.1-2 N 4.1-2, 5.2 S 1.1-3

Nenngröße Nom. size	P	l_1	l_2	l_3	$\varnothing d_1$	$\varnothing d_2$	Z
D	Gg/1" (tpi)						
1/16	27	55	9,88	36	5,9	8	3
1/8	27	55	9,88	36	7,65	8	3
1/4	18	75	14,79	45	10,15	12	4
3/8	18	75	14,78	45	11,15	12	4
1/2 - 3/4	14	80	19,01	48	14,25	16	4
1" - 2"	11 1/2	90	23,14	50	19,6	20	5

GF-KEG-VHM IKZ-HB	GF-KEG-VHM IKZ-HE	GF-KEG-VHM IKZ-HA
GF173101.5763 ●	GF173401.5763 ●	GF173701.5763 ●
GF173101.5764 ●	GF173401.5764 ●	GF173701.5764 ●
GF173111.5765 ●	GF173411.5765 ●	GF173711.5765 ●
GF173111.5766 ●	GF173411.5766 ●	GF173711.5766 ●
GF173131.9678 ●	GF173431.9678 ●	GF173731.9678 ●
GF173151.9679 ●	GF173451.9679 ●	GF173751.9679 ●

TICN



Einsatzgebiete – Material
Applications – material

P 1.1-5.1 M 1.1-4.1 K 1.1-4.2
N 1.1-5.2 S 1.1-2.6 H 1.1-2

Nenngröße Nom. size	P	l_1	l_2	l_3	$\varnothing d_1$	$\varnothing d_2$	Z
D	Gg/1" (tpi)						
1/16	27	55	9,88	36	5,9	8	3
1/8	27	55	9,88	36	7,65	8	3
1/4	18	75	14,79	45	10,15	12	4
3/8	18	75	14,78	45	11,15	12	4
1/2 - 3/4	14	80	19,01	48	14,25	16	4
1" - 2"	11 1/2	90	23,14	50	19,6	20	5

GF-KEG-VHM IKZ-HB TICN	GF-KEG-VHM IKZ-HE TICN	GF-KEG-VHM IKZ-HA TICN
GF173106.5763 ●	GF173406.5763 ●	GF173706.5763 ●
GF173106.5764 ●	GF173406.5764 ●	GF173706.5764 ●
GF173116.5765 ●	GF173416.5765 ●	GF173716.5765 ●
GF173116.5766 ●	GF173416.5766 ●	GF173716.5766 ●
GF173136.9678 ●	GF173436.9678 ●	GF173736.9678 ●
GF173156.9679 ●	GF173456.9679 ●	GF173756.9679 ●

NPT-Fräser werden mit korrigiertem Profil gefertigt
NPT cutters are manufactured with a corrected profile

Anwendungshinweis: Es wird ein NC-Programm für schneckenförmiges Wendelnutfräsen benötigt, da sonst ein Absatz im gefrästen Gewinde entsteht
Application recommendation: You must have an NC programme for spiral-worm keyway milling, otherwise the finished thread will have a stepped profile

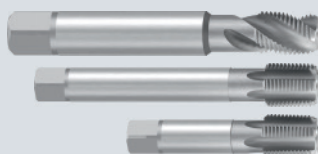

Gewindebohrer für kegelige
Innengewinde siehe Seite 184 - 197

Taps for internal tapered threads,
see page 184 - 197

- Product Finder
- v_c / f_z
- M
- MF
- UNC UN, UNS
- UNF UNEF
- G, Rp
- NPT, NPTF Rc, W
- BSW, BSF
- Pg
- EG (STI) SELF-LOCK
- Tr
- Zubehör Accessories
- Tech. Info
- BGF
- ZBGF
- GSF
- GF
- GF-KEG
- ZGF
- ZIRK-GF
- Gigant
- MoSys



ANSI/ASME B1.20.1

Für kegeliges Innengewinde
For internal tapered threads

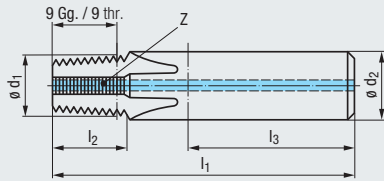

VHM

RH + LH

Z3 - Z5

DIN 6535

HB
HE
HA



new



new



new



Einsatzgebiete – Material
Applications – material

» 328

P 1.1-5.1 K 1.1-4.2 N 1.1-5, 2.1-6
N 3.1-2 N 4.1-2, 5.2 S 1.1-3

Nenngröße

Nom. size

D	P Gg/1" (tpi)	l_1	l_2	l_3	$\varnothing d_1$	$\varnothing d_2$	Z
1/16	27	55	9,88	36	5,9	8	3
1/8	27	55	9,88	36	7,65	8	3
1/4	18	75	14,79	45	10,15	12	4
3/8	18	75	14,78	45	11,15	12	4
1/2 - 3/4	14	80	19,01	48	14,25	16	4
1" - 2"	11 1/2	90	23,14	50	19,6	20	5

GF-KEG-VHM
IKZN-HB

GF-KEG-VHM
IKZN-HE

GF-KEG-VHM
IKZN-HA

GF193101.5763	●	GF193401.5763	●	GF193701.5763	●
GF193101.5764	●	GF193401.5764	●	GF193701.5764	●
GF193111.5765	●	GF193411.5765	●	GF193711.5765	●
GF193111.5766	●	GF193411.5766	●	GF193711.5766	●
GF193131.9678	●	GF193431.9678	●	GF193731.9678	●
GF193151.9679	●	GF193451.9679	●	GF193751.9679	●

TICN

new



new



new



Einsatzgebiete – Material
Applications – material

» 328

P 1.1-5.1 M 1.1-4.1 K 1.1-4.2
N 1.1-5.2 S 1.1-2.6 H 1.1-2

Nenngröße

Nom. size

D	P Gg/1" (tpi)	l_1	l_2	l_3	$\varnothing d_1$	$\varnothing d_2$	Z
1/16	27	55	9,88	36	5,9	8	3
1/8	27	55	9,88	36	7,65	8	3
1/4	18	75	14,79	45	10,15	12	4
3/8	18	75	14,78	45	11,15	12	4
1/2 - 3/4	14	80	19,01	48	14,25	16	4
1" - 2"	11 1/2	90	23,14	50	19,6	20	5

GF-KEG-VHM
IKZN-HB
TICN

GF-KEG-VHM
IKZN-HE
TICN

GF-KEG-VHM
IKZN-HA
TICN

GF193106.5763	●	GF193406.5763	●	GF193706.5763	●
GF193106.5764	●	GF193406.5764	●	GF193706.5764	●
GF193116.5765	●	GF193416.5765	●	GF193716.5765	●
GF193116.5766	●	GF193416.5766	●	GF193716.5766	●
GF193136.9678	●	GF193436.9678	●	GF193736.9678	●
GF193156.9679	●	GF193456.9679	●	GF193756.9679	●

NPT-Fräser werden mit korrigiertem Profil gefertigt
NPT cutters are manufactured with a corrected profile

Anwendungshinweis: Es wird ein NC-Programm für schneckenförmiges Wendelnutfräsen benötigt, da sonst ein Absatz im gefrästen Gewinde entsteht
Application recommendation: You must have an NC programme for spiral-worm keyway milling, otherwise the finished thread will have a stepped profile

NPT (API-LP)

ANSI/ASME B1.20.1



VHM

R15

RH + LH

Z3 - Z5



DIN 6535



Für kegeliges Innengewinde
For internal tapered threads

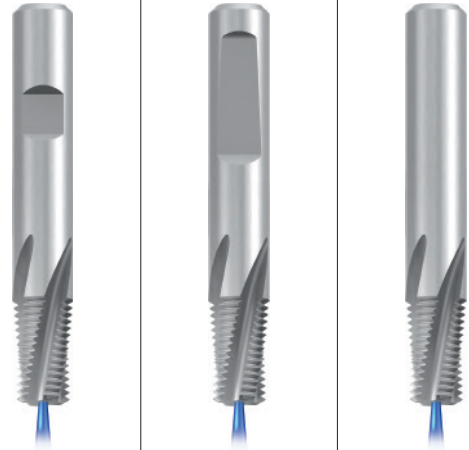
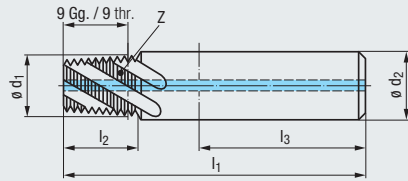

Einsatzgebiete – Material
Applications – material

P 1.1-5.1 K 1.1-4.2 N 1.1-5, 2.1-6
N 3.1-2 N 4.1-2, 5.2 S 1.1-3

Nenngröße Nom. size	P Gg/1" (tpi)	l ₁	l ₂	l ₃	ø d ₁	ø d ₂	Z
1/16	27	60	13,63	36	5,9	8	3
1/8	27	60	13,63	36	7,65	8	3
1/4	18	80	20,44	45	10,15	12	4
3/8	18	80	20,43	45	11,15	12	4
1/2 - 3/4	14	85	26,27	48	14,25	16	4
1" - 2"	11 1/2	95	31,98	50	19,6	20	5

GF-KEG-VHM R15-Ig-IKZ-HB	GF-KEG-VHM R15-Ig-IKZ-HE	GF-KEG-VHM R15-Ig-IKZ-HA
GF175301.5763 ●	GF175601.5763 ●	GF175901.5763 ●
GF175301.5764 ●	GF175601.5764 ●	GF175901.5764 ●
GF175311.5765 ●	GF175611.5765 ●	GF175911.5765 ●
GF175311.5766 ●	GF175611.5766 ●	GF175911.5766 ●
GF175331.9678 ●	GF175631.9678 ●	GF175931.9678 ●
GF175351.9679 ●	GF175651.9679 ●	GF175951.9679 ●

TICN



Einsatzgebiete – Material
Applications – material

P 1.1-5.1 M 1.1-4.1 K 1.1-4.2
N 1.1-5.2 S 1.1-2.6 H 1.1-2

Nenngröße Nom. size	P Gg/1" (tpi)	l ₁	l ₂	l ₃	ø d ₁	ø d ₂	Z
1/16	27	60	13,63	36	5,9	8	3
1/8	27	60	13,63	36	7,65	8	3
1/4	18	80	20,44	45	10,15	12	4
3/8	18	80	20,43	45	11,15	12	4
1/2 - 3/4	14	85	26,27	48	14,25	16	4
1" - 2"	11 1/2	95	31,98	50	19,6	20	5

GF-KEG-VHM R15-Ig-IKZ-HB TICN	GF-KEG-VHM R15-Ig-IKZ-HE TICN	GF-KEG-VHM R15-Ig-IKZ-HA TICN
GF175306.5763 ●	GF175606.5763 ●	GF175906.5763 ●
GF175306.5764 ●	GF175606.5764 ●	GF175906.5764 ●
GF175316.5765 ●	GF175616.5765 ●	GF175916.5765 ●
GF175316.5766 ●	GF175616.5766 ●	GF175916.5766 ●
GF175336.9678 ●	GF175636.9678 ●	GF175936.9678 ●
GF175356.9679 ●	GF175656.9679 ●	GF175956.9679 ●

NPT/API-LP-Fräser werden mit korrigiertem Profil gefertigt
NPT/API-LP cutters are manufactured with a corrected profile

Anwendungshinweis: Es wird ein NC-Programm für schneckenförmiges Wendelnutfräsen benötigt, da sonst ein Absatz im gefrästen Gewinde entsteht
Application recommendation: You must have an NC programme for spiral-worm keyway milling, otherwise the finished thread will have a stepped profile

Product Finder

v_c / f_z

M

MF

UNC
UN, UNS

UNF
UNEF

G, Rp

NPT NPTF
Rc, W

BSW, BSF

Pg

EG (STI)
SELF-LOCK

Tr

Zubehör
Accessories

Tech. Info

BGF

ZBGF

GSF

GF

GF-KEG

ZGF

ZIRK-GF

Gigant

MoSys

- Product Finder
- v_c / f_z
- M
- MF
- UNC UN, UNS
- UNF UNEF
- G, Rp
- NPT, NPTF Rc, W
- BSW, BSF
- Pg
- EG (STI) SELF-LOCK
- Tr
- Zubehör Accessories
- Tech. Info
- BGF
- ZBGF
- GSF
- GF
- GF-KEG
- ZGF
- ZIRK-GF
- Gigant
- MoSys

NPT (API-LP)

ANSI/ASME B1.20.1



Für kegeliges Innengewinde
For internal tapered threads

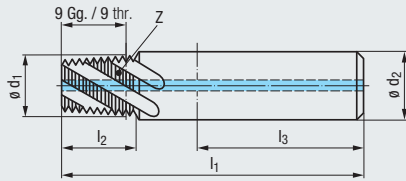

VHM

R15

RH + LH

Z3 - Z5

DIN 6535

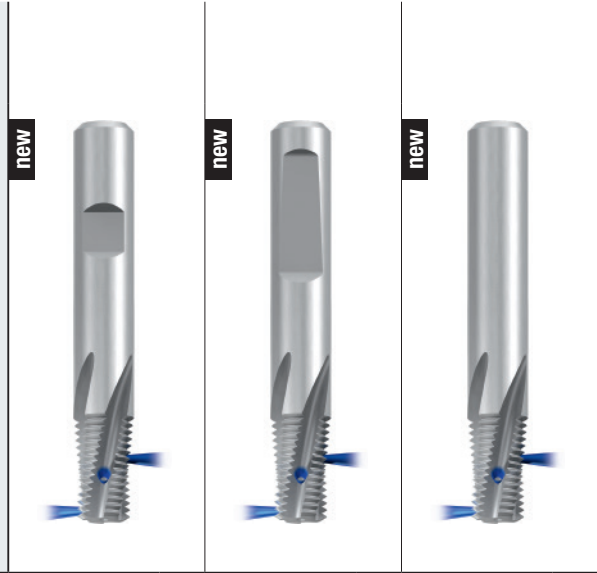

Einsatzgebiete – Material
Applications – material

» 328

P 1.1-5.1 K 1.1-4.2 N 1.1-5, 2.1-6
N 3.1-2 N 4.1-2, 5.2 S 1.1-3

Nenngröße
Nom. size

D	P Gg/1" (tpi)	l_1	l_2	l_3	$\varnothing d_1$	$\varnothing d_2$	Z	GF-KEG-VHM R15-Ig- IKZN -HB	GF-KEG-VHM R15-Ig- IKZN -HE	GF-KEG-VHM R15-Ig- IKZN -HA
1/16	27	60	13,63	36	5,9	8	3	GF195301.5763	GF195601.5763	GF195901.5763
1/8	27	60	13,63	36	7,65	8	3	GF195301.5764	GF195601.5764	GF195901.5764
1/4	18	80	20,44	45	10,15	12	4	GF195311.5765	GF195611.5765	GF195911.5765
3/8	18	80	20,43	45	11,15	12	4	GF195311.5766	GF195611.5766	GF195911.5766
1/2 - 3/4	14	85	26,27	48	14,25	16	4	GF195331.9678	GF195631.9678	GF195931.9678
1" - 2"	11 1/2	95	31,98	50	19,6	20	5	GF195351.9679	GF195651.9679	GF195951.9679

TICN

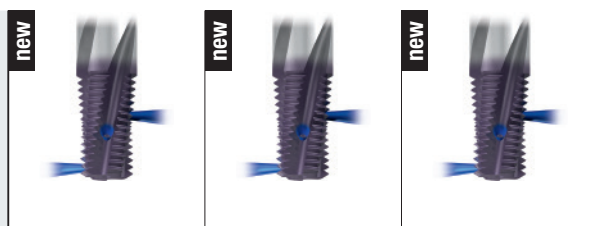

Einsatzgebiete – Material
Applications – material

» 328

P 1.1-5.1 M 1.1-4.1 K 1.1-4.2
N 1.1-5.2 S 1.1-2.6 H 1.1-2

Nenngröße
Nom. size

D	P Gg/1" (tpi)	l_1	l_2	l_3	$\varnothing d_1$	$\varnothing d_2$	Z	GF-KEG-VHM R15-Ig- IKZN -HB TICN	GF-KEG-VHM R15-Ig- IKZN -HE TICN	GF-KEG-VHM R15-Ig- IKZN -HA TICN
1/16	27	60	13,63	36	5,9	8	3	GF195306.5763	GF195606.5763	GF195906.5763
1/8	27	60	13,63	36	7,65	8	3	GF195306.5764	GF195606.5764	GF195906.5764
1/4	18	80	20,44	45	10,15	12	4	GF195316.5765	GF195616.5765	GF195916.5765
3/8	18	80	20,43	45	11,15	12	4	GF195316.5766	GF195616.5766	GF195916.5766
1/2 - 3/4	14	85	26,27	48	14,25	16	4	GF195336.9678	GF195636.9678	GF195936.9678
1" - 2"	11 1/2	95	31,98	50	19,6	20	5	GF195356.9679	GF195656.9679	GF195956.9679

NPT/API-LP-Fräser werden mit korrigiertem Profil gefertigt
NPT/API-LP cutters are manufactured with a corrected profile

Anwendungshinweis: Es wird ein NC-Programm für schneckenförmiges Wendelnutfräsen benötigt, da sonst ein Absatz im gefrästen Gewinde entsteht
Application recommendation: You must have an NC programme for spiral-worm keyway milling, otherwise the finished thread will have a stepped profile

NPTF

ANSI B1.20.3



EMUGE NPTF-Gewindefräser sind für die Lochformen a) und b) geeignet.

EMUGE NPTF thread milling cutters are suited for the hole forms a) and b).

a) Zylindrisch vorarbeiten

Cylindrical preparation of thread hole

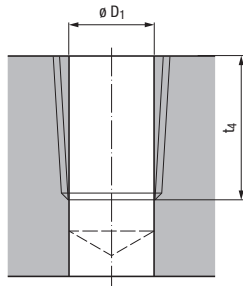

Nenngröße Nom. size D	P Gg/1" (tpi)	$\varnothing D_1$	t_4
1/16	27	6,10	8,30
1/8	27	8,45	8,30
1/4	18	10,90	12,15
3/8	18	14,30	12,45
1/2	14	17,60	16,30
3/4	14	23,00	16,30
1"	11 1/2	28,75	19,55
1 1/4	11 1/2	37,50	20,05
1 1/2	11 1/2	43,75	20,05
2"	11 1/2	55,75	20,45

b) Kegelig vorarbeiten

Tapered preparation of thread hole

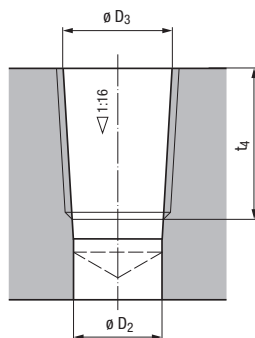

Nenngröße Nom. size D	P Gg/1" (tpi)	$\varnothing D_2$	$\varnothing D_3$ +0,05	t_4
1/16	27	5,95	6,41	8,30
1/8	27	8,30	8,76	8,30
1/4	18	10,75	11,40	12,15
3/8	18	14,15	14,84	12,45
1/2	14	17,45	18,33	16,30
3/4	14	22,80	23,68	16,30
1"	11 1/2	28,65	29,72	19,55
1 1/4	11 1/2	37,35	38,48	20,05
1 1/2	11 1/2	43,45	44,55	20,05
2"	11 1/2	55,45	56,59	20,45

Product Finder

v_c / f_z

M

MF

UNC
UN, UNS

UNF
UNEF

G, Rp

NPT, NPTF
Rc, W

BSW, BSF

Pg

EG (STI)
SELF-LOCK

Tr

Zubehör
Accessories

Tech. Info

BGF

ZBGF

GSF

GF

GF-KEG

ZGF

ZIRK-GF

Gigant

MoSys



- Product Finder
- v_c / f_z
- M
- MF
- UNC
UN, UNS
- UNF
UNEF
- G, Rp
- NPT NPTF
Rc, W
- BSW, BSF
- Pg
- EG (STI)
SELF-LOCK
- Tr
- Zubehör
Accessories
- Tech. Info
- BGF
- ZBGF
- GSF
- GF
- GF-KEG
- ZGF
- ZIRK-GF
- Gigant
- MoSys



NPTF

ANSI B1.20.3

Für kegeliges Innengewinde
For internal tapered threads

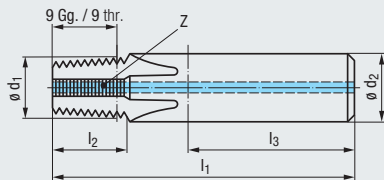

VHM

RH + LH

Z3 - Z5

DIN 6535

HB
HE
HA



Einsatzgebiete – Material
Applications – material

» 328

P 1.1-5.1 K 1.1-4.2 N 1.1-5, 2.1-6
N 3.1-2 N 4.1-2, 5.2 S 1.1-3

Nenngröße

Nom. size

D	P Gg/1" (tpi)	l_1	l_2	l_3	$\varnothing d_1$	$\varnothing d_2$	Z
1/16	27	55	9,84	36	5,9	8	3
1/8	27	55	9,83	36	7,65	8	3
1/4	18	75	14,77	45	10,15	12	4
3/8	18	75	14,76	45	11,15	12	4
1/2	14	80	19	48	14,25	16	4
3/4	14	80	19	48	14,25	16	4
1" - 2"	11 1/2	90	23,13	50	19,6	20	5

GF-KEG-VHM
IKZ-HB

GF-KEG-VHM
IKZ-HE

GF-KEG-VHM
IKZ-HA

GF173101.5782	●	GF173401.5782	●	GF173701.5782	●
GF173101.5783	●	GF173401.5783	●	GF173701.5783	●
GF173111.5784	●	GF173411.5784	●	GF173711.5784	●
GF173111.5785	●	GF173411.5785	●	GF173711.5785	●
GF173131.5786	●	GF173431.5786	●	GF173731.5786	●
GF173131.5787	●	GF173431.5787	●	GF173731.5787	●
GF173151.9684	●	GF173451.9684	●	GF173751.9684	●

TICN



Einsatzgebiete – Material
Applications – material

» 328

P 1.1-5.1 M 1.1-4.1 K 1.1-4.2
N 1.1-5.2 S 1.1-2.6 H 1.1-2

Nenngröße

Nom. size

D	P Gg/1" (tpi)	l_1	l_2	l_3	$\varnothing d_1$	$\varnothing d_2$	Z
1/16	27	55	9,84	36	5,9	8	3
1/8	27	55	9,83	36	7,65	8	3
1/4	18	75	14,77	45	10,15	12	4
3/8	18	75	14,76	45	11,15	12	4
1/2	14	80	19	48	14,25	16	4
3/4	14	80	19	48	14,25	16	4
1" - 2"	11 1/2	90	23,13	50	19,6	20	5

GF-KEG-VHM
IKZ-HB
TICN

GF-KEG-VHM
IKZ-HE
TICN

GF-KEG-VHM
IKZ-HA
TICN

GF173106.5782	●	GF173406.5782	●	GF173706.5782	●
GF173106.5783	●	GF173406.5783	●	GF173706.5783	●
GF173116.5784	●	GF173416.5784	●	GF173716.5784	●
GF173116.5785	●	GF173416.5785	●	GF173716.5785	●
GF173136.5786	●	GF173436.5786	●	GF173736.5786	●
GF173136.5787	●	GF173436.5787	●	GF173736.5787	●
GF173156.9684	●	GF173456.9684	●	GF173756.9684	●

NPTF-Fräser werden mit korrigiertem Profil gefertigt
NPTF cutters are manufactured with a corrected profile

Anwendungshinweis: Es wird ein NC-Programm für schneckenförmiges Wendelnutfräsen benötigt, da sonst ein Absatz im gefrästen Gewinde entsteht
Application recommendation: You must have an NC programme for spiral-worm keyway milling, otherwise the finished thread will have a stepped profile

NPTF

ANSI B1.20.3



Für kegeliges Innengewinde
For internal tapered threads

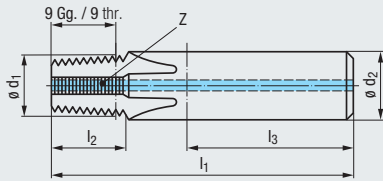

VHM

RH + LH

Z3 - Z5



DIN 6535



new



new



new



Einsatzgebiete – Material
Applications – material



P 1.1-5.1 K 1.1-4.2 N 1.1-5, 2.1-6
N 3.1-2 N 4.1-2, 5.2 S 1.1-3

Nenngröße
Nom. size

D	P Gg/1" (tpi)	l_1	l_2	l_3	$\varnothing d_1$	$\varnothing d_2$	Z	GF-KEG-VHM IKZN-HB	GF-KEG-VHM IKZN-HE	GF-KEG-VHM IKZN-HA
1/16	27	55	9,84	36	5,9	8	3	GF193101.5782	GF193401.5782	GF193701.5782
1/8	27	55	9,83	36	7,65	8	3	GF193101.5783	GF193401.5783	GF193701.5783
1/4	18	75	14,77	45	10,15	12	4	GF193111.5784	GF193411.5784	GF193711.5784
3/8	18	75	14,76	45	11,15	12	4	GF193111.5785	GF193411.5785	GF193711.5785
1/2	14	80	19	48	14,25	16	4	GF193131.5786	GF193431.5786	GF193731.5786
3/4	14	80	19	48	14,25	16	4	GF193131.5787	GF193431.5787	GF193731.5787
1" - 2"	11 1/2	90	23,13	50	19,6	20	5	GF193151.9684	GF193451.9684	GF193751.9684

TICN

new



new



new



Einsatzgebiete – Material
Applications – material



P 1.1-5.1 M 1.1-4.1 K 1.1-4.2
N 1.1-5.2 S 1.1-2.6 H 1.1-2

Nenngröße
Nom. size

D	P Gg/1" (tpi)	l_1	l_2	l_3	$\varnothing d_1$	$\varnothing d_2$	Z	GF-KEG-VHM IKZN-HB TICN	GF-KEG-VHM IKZN-HE TICN	GF-KEG-VHM IKZN-HA TICN
1/16	27	55	9,84	36	5,9	8	3	GF193106.5782	GF193406.5782	GF193706.5782
1/8	27	55	9,83	36	7,65	8	3	GF193106.5783	GF193406.5783	GF193706.5783
1/4	18	75	14,77	45	10,15	12	4	GF193116.5784	GF193416.5784	GF193716.5784
3/8	18	75	14,76	45	11,15	12	4	GF193116.5785	GF193416.5785	GF193716.5785
1/2	14	80	19	48	14,25	16	4	GF193136.5786	GF193436.5786	GF193736.5786
3/4	14	80	19	48	14,25	16	4	GF193136.5787	GF193436.5787	GF193736.5787
1" - 2"	11 1/2	90	23,13	50	19,6	20	5	GF193156.9684	GF193456.9684	GF193756.9684

NPTF-Fräser werden mit korrigiertem Profil gefertigt
NPTF cutters are manufactured with a corrected profile

Anwendungshinweis: Es wird ein NC-Programm für schneckenförmiges Wendelnutfräsen benötigt, da sonst ein Absatz im gefrästen Gewinde entsteht
Application recommendation: You must have an NC programme for spiral-worm keyway milling, otherwise the finished thread will have a stepped profile

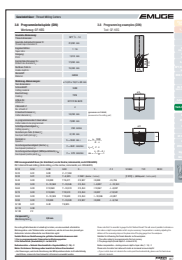

Programmierbeispiel für kegelige
Gewindefräser Typ GF-KEG
siehe Seite 467

Programming example for tapered
thread milling cutters type GF-KEG,
see page 467

- Product Finder
- v_c / f_z
- M
- MF
- UNC
UN, UNS
- UNF
UNEF
- G, Rp
- NPT NPTF
Rc, W
- BSW, BSF
- Pg
- EG (STI)
SELF-LOCK
- Tr
- Zubehör
Accessories
- Tech. Info
- BGF
- ZBGF
- GSF
- GF
- GF-KEG
- ZGF
- ZIRK-GF
- Gigant
- MoSys

NPTF



ANSI B1.20.3

Für kegeliges Innengewinde
For internal tapered threads

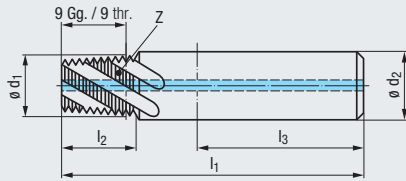

VHM

R15

RH + LH

Z3 - Z5

DIN 6535



Einsatzgebiete – Material
Applications – material

» 328

P 1.1-5.1 K 1.1-4.2 N 1.1-5, 2.1-6
N 3.1-2 N 4.1-2, 5.2 S 1.1-3

Nenngröße
Nom. size

D	P Gg/1" (tpi)	l_1	l_2	l_3	$\varnothing d_1$	$\varnothing d_2$	Z
1/16	27	60	13,6	36	5,9	8	3
1/8	27	60	13,6	36	7,65	8	3
1/4	18	80	20,41	45	10,15	12	4
3/8	18	80	20,4	45	11,15	12	4
1/2	14	85	26,25	48	14,25	16	4
3/4	14	85	26,25	48	14,25	16	4
1" - 2"	11 1/2	95	31,96	50	19,6	20	5

GF-KEG-VHM
R15-Ig-IKZ-HB

GF-KEG-VHM
R15-Ig-IKZ-HE

GF-KEG-VHM
R15-Ig-IKZ-HA

GF175301.5782	●	GF175601.5782	●	GF175901.5782	●
GF175301.5783	●	GF175601.5783	●	GF175901.5783	●
GF175311.5784	●	GF175611.5784	●	GF175911.5784	●
GF175311.5785	●	GF175611.5785	●	GF175911.5785	●
GF175331.5786	●	GF175631.5786	●	GF175931.5786	●
GF175331.5787	●	GF175631.5787	●	GF175931.5787	●
GF175351.9684	●	GF175651.9684	●	GF175951.9684	●

TICN



Einsatzgebiete – Material
Applications – material

» 328

P 1.1-5.1 M 1.1-4.1 K 1.1-4.2
N 1.1-5.2 S 1.1-2.6 H 1.1-2

Nenngröße
Nom. size

D	P Gg/1" (tpi)	l_1	l_2	l_3	$\varnothing d_1$	$\varnothing d_2$	Z
1/16	27	60	13,6	36	5,9	8	3
1/8	27	60	13,6	36	7,65	8	3
1/4	18	80	20,41	45	10,15	12	4
3/8	18	80	20,4	45	11,15	12	4
1/2	14	85	26,25	48	14,25	16	4
3/4	14	85	26,25	48	14,25	16	4
1" - 2"	11 1/2	95	31,96	50	19,6	20	5

GF-KEG-VHM
R15-Ig-IKZ-HB
TICN

GF-KEG-VHM
R15-Ig-IKZ-HE
TICN

GF-KEG-VHM
R15-Ig-IKZ-HA
TICN

GF175306.5782	●	GF175606.5782	●	GF175906.5782	●
GF175306.5783	●	GF175606.5783	●	GF175906.5783	●
GF175316.5784	●	GF175616.5784	●	GF175916.5784	●
GF175316.5785	●	GF175616.5785	●	GF175916.5785	●
GF175336.5786	●	GF175636.5786	●	GF175936.5786	●
GF175336.5787	●	GF175636.5787	●	GF175936.5787	●
GF175356.9684	●	GF175656.9684	●	GF175956.9684	●

NPTF-Fräser werden mit korrigiertem Profil gefertigt
NPTF cutters are manufactured with a corrected profile

Anwendungshinweis: Es wird ein NC-Programm für schneckenförmiges Wendelnutfräsen benötigt, da sonst ein Absatz im gefrästen Gewinde entsteht
Application recommendation: You must have an NC programme for spiral-worm keyway milling, otherwise the finished thread will have a stepped profile

NPTF

ANSI B1.20.3



Für kegeliges Innengewinde
For internal tapered threads

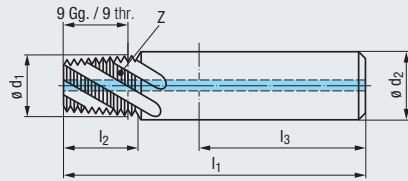

VHM

R15 **RH + LH**

Z3 - Z5 **DIN 6535**
 HB
 HE
 HA

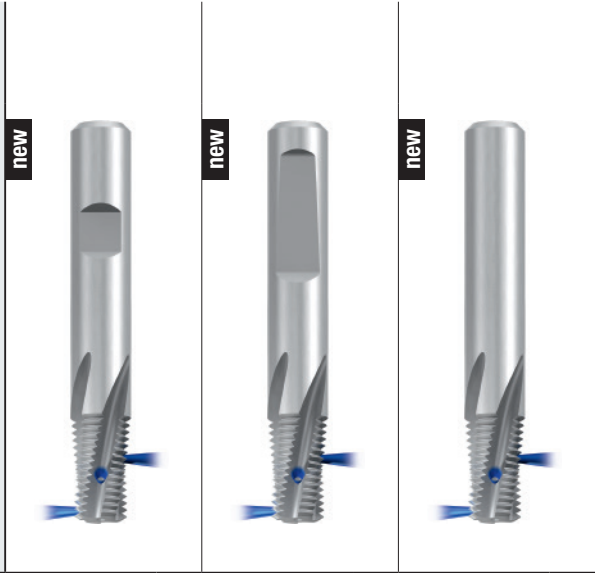

Einsatzgebiete – Material 328
 Applications – material

P 1.1-5.1 **K** 1.1-4.2 **N** 1.1-5, 2.1-6
N 3.1-2 **N** 4.1-2, 5.2 **S** 1.1-3

Nenngröße Nom. size								GF-KEG-VHM R15-Ig-IKZN-HB	GF-KEG-VHM R15-Ig-IKZN-HE	GF-KEG-VHM R15-Ig-IKZN-HA
D	P Gg/1" (tpi)	l_1	l_2	l_3	$\varnothing d_1$	$\varnothing d_2$	Z			
1/16	27	60	13,6	36	5,9	8	3	GF195301.5782 ●	GF195601.5782 ●	GF195901.5782 ●
1/8	27	60	13,6	36	7,65	8	GF195301.5783 ●	GF195601.5783 ●	GF195901.5783 ●	
1/4	18	80	20,41	45	10,15	12	GF195311.5784 ●	GF195611.5784 ●	GF195911.5784 ●	
3/8	18	80	20,4	45	11,15	12	GF195311.5785 ●	GF195611.5785 ●	GF195911.5785 ●	
1/2	14	85	26,25	48	14,25	16	GF195331.5786 ●	GF195631.5786 ●	GF195931.5786 ●	
3/4	14	85	26,25	48	14,25	16	GF195331.5787 ●	GF195631.5787 ●	GF195931.5787 ●	
1" - 2"	11 1/2	95	31,96	50	19,6	20	GF195351.9684 ●	GF195651.9684 ●	GF195951.9684 ●	

TICN

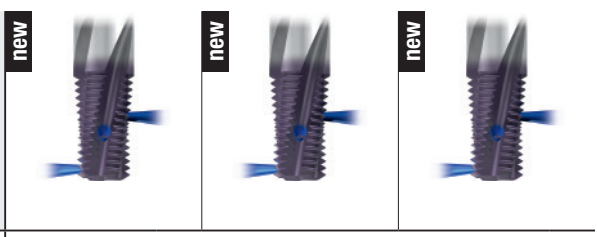

Einsatzgebiete – Material 328
 Applications – material

P 1.1-5.1 **M** 1.1-4.1 **K** 1.1-4.2
N 1.1-5.2 **S** 1.1-2.6 **H** 1.1-2

Nenngröße Nom. size								GF-KEG-VHM R15-Ig-IKZN-HB TICN	GF-KEG-VHM R15-Ig-IKZN-HE TICN	GF-KEG-VHM R15-Ig-IKZN-HA TICN
D	P Gg/1" (tpi)	l_1	l_2	l_3	$\varnothing d_1$	$\varnothing d_2$	Z			
1/16	27	60	13,6	36	5,9	8	3	GF195306.5782 ●	GF195606.5782 ●	GF195906.5782 ●
1/8	27	60	13,6	36	7,65	8	3	GF195306.5783 ●	GF195606.5783 ●	GF195906.5783 ●
1/4	18	80	20,41	45	10,15	12	4	GF195316.5784 ●	GF195616.5784 ●	GF195916.5784 ●
3/8	18	80	20,4	45	11,15	12	4	GF195316.5785 ●	GF195616.5785 ●	GF195916.5785 ●
1/2	14	85	26,25	48	14,25	16	4	GF195336.5786 ●	GF195636.5786 ●	GF195936.5786 ●
3/4	14	85	26,25	48	14,25	16	4	GF195336.5787 ●	GF195636.5787 ●	GF195936.5787 ●
1" - 2"	11 1/2	95	31,96	50	19,6	20	5	GF195356.9684 ●	GF195656.9684 ●	GF195956.9684 ●

NPTF-Fräser werden mit korrigiertem Profil gefertigt
 NPTF cutters are manufactured with a corrected profile

Anwendungshinweis: Es wird ein NC-Programm für schneckenförmiges Wendelnutfräsen benötigt, da sonst ein Absatz im gefrästen Gewinde entsteht
 Application recommendation: You must have an NC programme for spiral-worm keyway milling, otherwise the finished thread will have a stepped profile

Product Finder

v_c / f_z

M

MF

UNC
UN, UNS

UNF
UNEF

G, Rp

NPT, NPTF
Rc, W

BSW, BSF

Pg

EG (STI)
SELF-LOCK

Tr

Zubehör
Accessories

Tech. Info

BGF

ZBGF

GSF

GF

GF-KEG

ZGF

ZIRK-GF

Gigant

MoSys

Product Finder

v_c / f_z

M

MF

UNC
UN, UNS

UNF
UNEF

G, Rp

NPT, NPTF
Rc, W

BSW, BSF

Pg

EG (STI)
SELF-LOCK

Tr

Zubehör
Accessories

Tech. Info

BGF

ZBGF

GSF

GF

GF-KEG

ZGF

ZIRK-GF

Gigant

MoSys

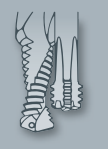

Rc (BSPT)

DIN EN 10226-2, ISO 7-1



a) Zylindrisch vorarbeiten
Cylindrical preparation of thread hole

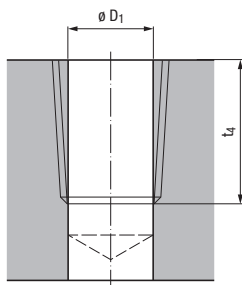

b) Kegelig vorarbeiten
Tapered preparation of thread hole

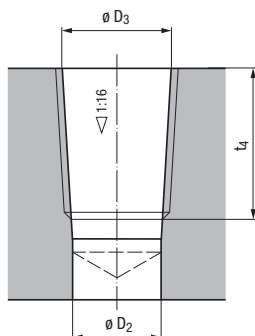

EMUGE Rc-Gewindebohrer sind für die Lochformen a) und b) geeignet. Die Lochform a) kann angewendet werden, wenn keine Dichtprobleme zu befürchten sind.

EMUGE Rc taps are suited for the hole forms a) and b). Hole type a) can be used when there is no reason to worry about sealing problems.

Nenngröße Nom. size D	P Gg/1" (tpi)	$\varnothing D_1$	t_4
Rc 1/16	28	6,15	7,85
1/8	28	8,15	7,85
1/4	19	10,85	11,65
3/8	19	14,3	12,05
1/2	14	17,8	15,9
3/4	14	23,2	16,75
1"	11	29,2	19,65
1 1/4	11	37,8	21,95
1 1/2	11	43,7	21,95
2"	11	55,2	26,25

Nenngröße Nom. size D	P Gg/1" (tpi)	$\varnothing D_2$	$\varnothing D_3$ (JS11)	t_4
Rc 1/16	28	6,1	6,56	7,85
1/8	28	8,1	8,57	7,85
1/4	19	10,75	11,45	11,65
3/8	19	14,25	14,95	12,05
1/2	14	17,7	18,63	15,9
3/4	14	23,1	24,12	16,75
1"	11	29,1	30,29	19,65
1 1/4	11	37,6	38,95	21,95
1 1/2	11	43,5	44,85	21,95
2"	11	55	56,66	26,25

Rc (BSPT)

DIN EN 10226-2, ISO 7-1



VHM

RH + LH

Z3 - Z5



DIN 6535



Für kegeliges Innengewinde
For internal tapered threads

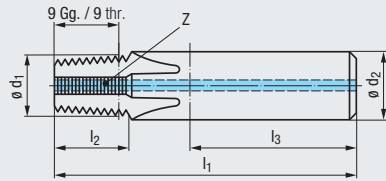

Einsatzgebiete – Material
Applications – material

» 328

Nenngröße
Nom. size

	D	P Gg/1" (tpi)	l ₁	l ₂	l ₃	ø d ₁	ø d ₂	Z
Rc 1/16	28	28	55	8,56	36	5,9	8	3
1/8	28	28	55	8,56	36	7,65	8	3
1/4	19	75	75	13,96	45	10,15	12	4
3/8	19	75	75	13,96	45	11,15	12	4
1/2 - 3/4	14	80	80	19,06	48	14,25	16	4
1" - 2"	11	90	90	24,26	50	19,6	20	5

P 1.1-5.1 K 1.1-4.2 N 1.1-5, 2.1-6
N 3.1-2 N 4.1-2, 5.2 S 1.1-3

GF-KEG-VHM IKZ-HB	GF-KEG-VHM IKZ-HE	GF-KEG-VHM IKZ-HA
GF173101.4114	GF173401.4114	GF173701.4114
GF173101.4115 ●	GF173401.4115 ●	GF173701.4115 ●
GF173111.4116 ●	GF173411.4116 ●	GF173711.4116 ●
GF173111.4117 ●	GF173411.4117 ●	GF173711.4117 ●
GF173131.9561 ●	GF173431.9561 ●	GF173731.9561 ●
GF173151.9562 ●	GF173451.9562 ●	GF173751.9562 ●

TICN

Einsatzgebiete – Material
Applications – material

» 328

Nenngröße
Nom. size

	D	P Gg/1" (tpi)	l ₁	l ₂	l ₃	ø d ₁	ø d ₂	Z
Rc 1/16	28	28	55	8,56	36	5,9	8	3
1/8	28	28	55	8,56	36	7,65	8	3
1/4	19	75	75	13,96	45	10,15	12	4
3/8	19	75	75	13,96	45	11,15	12	4
1/2 - 3/4	14	80	80	19,06	48	14,25	16	4
1" - 2"	11	90	90	24,26	50	19,6	20	5

P 1.1-5.1 M 1.1-4.1 K 1.1-4.2
N 1.1-5.2 S 1.1-2.6 H 1.1-2

GF-KEG-VHM IKZ-HB TICN	GF-KEG-VHM IKZ-HE TICN	GF-KEG-VHM IKZ-HA TICN
GF173106.4114	GF173406.4114	GF173706.4114
GF173106.4115 ●	GF173406.4115 ●	GF173706.4115 ●
GF173116.4116 ●	GF173416.4116 ●	GF173716.4116 ●
GF173116.4117 ●	GF173416.4117 ●	GF173716.4117 ●
GF173136.9561 ●	GF173436.9561 ●	GF173736.9561 ●
GF173156.9562 ●	GF173456.9562 ●	GF173756.9562 ●

Rc-Fräser werden mit korrigiertem Profil gefertigt
Rc cutters are manufactured with a corrected profile

Anwendungshinweis: Es wird ein NC-Programm für schneckenförmiges Wendelnutfräsen benötigt, da sonst ein Absatz im gefrästen Gewinde entsteht
Application recommendation: You must have an NC programme for spiral-worm keyway milling, otherwise the finished thread will have a stepped profile



Schneideisen für kegeliges
Außengewinde siehe Seite 493

Dies for external tapered thread,
see page 493

- Product Finder
- v_c / f_z
- M
- MF
- UNC UN, UNS
- UNF UNEF
- G, Rp
- NPT, NPTF Rc W
- BSW, BSF
- Pg
- EG (STI) SELF-LOCK
- Tr
- Zubehör Accessories
- Tech. Info
- BGF
- ZBGF
- GSF
- GF
- GF-KEG
- ZGF
- ZIRK-GF
- Gigant
- MoSys

Rc (BSPT)

DIN EN 10226-2, ISO 7-1



VHM

RH + LH

Z3 - Z5



DIN 6535



Für kegeliges Innengewinde
For internal tapered threads

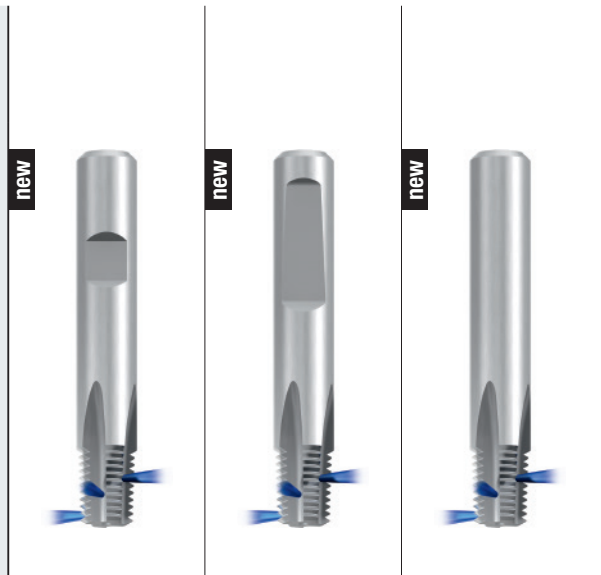
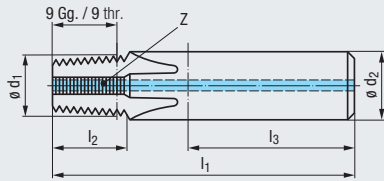

Einsatzgebiete – Material
Applications – material

» 328

P 1.1-5.1 K 1.1-4.2 N 1.1-5, 2.1-6
N 3.1-2 N 4.1-2, 5.2 S 1.1-3

Nenngröße
Nom. size

D	P Gg/1" (tpi)	l ₁	l ₂	l ₃	ø d ₁	ø d ₂	Z	GF-KEG-VHM		
								IKZN-HB	IKZN-HE	IKZN-HA
Rc 1/16	28	55	8,56	36	5,9	8	3	GF193101.4114	GF193401.4114	GF193701.4114
1/8	28	55	8,56	36	7,65	8	3	GF193101.4115	GF193401.4115	GF193701.4115
1/4	19	75	13,96	45	10,15	12	4	GF193111.4116	GF193411.4116	GF193711.4116
3/8	19	75	13,95	45	11,15	12	4	GF193111.4117	GF193411.4117	GF193711.4117
1/2 - 3/4	14	80	19,06	48	14,25	16	4	GF193131.9561	GF193431.9561	GF193731.9561
1" - 2"	11	90	24,26	50	19,6	20	5	GF193151.9562	GF193451.9562	GF193751.9562

TICN

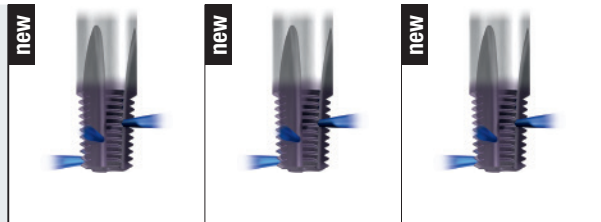

Einsatzgebiete – Material
Applications – material

» 328

P 1.1-5.1 M 1.1-4.1 K 1.1-4.2
N 1.1-5.2 S 1.1-2.6 H 1.1-2

Nenngröße
Nom. size

D	P Gg/1" (tpi)	l ₁	l ₂	l ₃	ø d ₁	ø d ₂	Z	GF-KEG-VHM		
								IKZN-HB TICN	IKZN-HE TICN	IKZN-HA TICN
Rc 1/16	28	55	8,56	36	5,9	8	3	GF193106.4114	GF193406.4114	GF193706.4114
1/8	28	55	8,56	36	7,65	8	3	GF193106.4115	GF193406.4115	GF193706.4115
1/4	19	75	13,96	45	10,15	12	4	GF193116.4116	GF193416.4116	GF193716.4116
3/8	19	75	13,95	45	11,15	12	4	GF193116.4117	GF193416.4117	GF193716.4117
1/2 - 3/4	14	80	19,06	48	14,25	16	4	GF193136.9561	GF193436.9561	GF193736.9561
1" - 2"	11	90	24,26	50	19,6	20	5	GF193156.9562	GF193456.9562	GF193756.9562

Rc-Fräser werden mit korrigiertem Profil gefertigt
Rc cutters are manufactured with a corrected profile

Anwendungshinweis: Es wird ein NC-Programm für schneckenförmiges Wendelnutfräsen benötigt, da sonst ein Absatz im gefrästen Gewinde entsteht
Application recommendation: You must have an NC programme for spiral-worm keyway milling, otherwise the finished thread will have a stepped profile

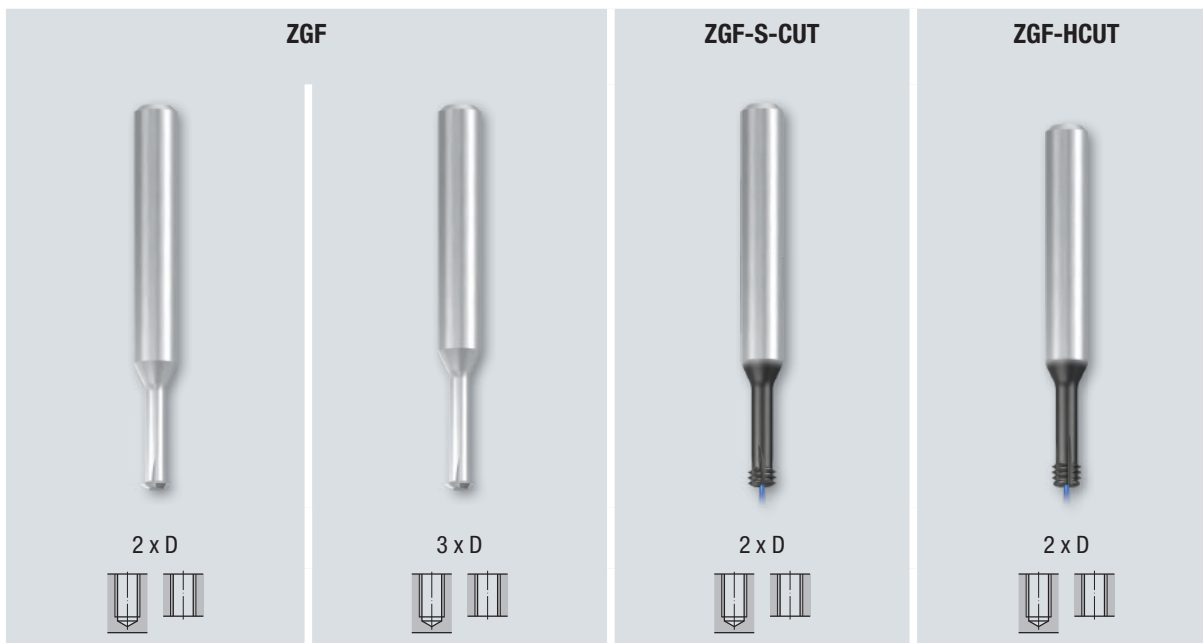

Seite · Page

414	415	416	417	M, MF
418	419	420		UNC
418	419	420		UNF

Product Finder

v_c / f_z

M

MF

UNC
UN, UNS

UNF
UNEF

G, Rp

NPT, NPTF
Rc, W

BSW, BSF

Pg

EG (STI)
SELF-LOCK

Tr

Zubehör
Accessories

Tech. Info

BGF

ZBGF

GSF

GF

GF-KEG

ZGF

ZIRK-GF

Gigant

MoSys



Gewindefräszyklus · Thread milling cycle

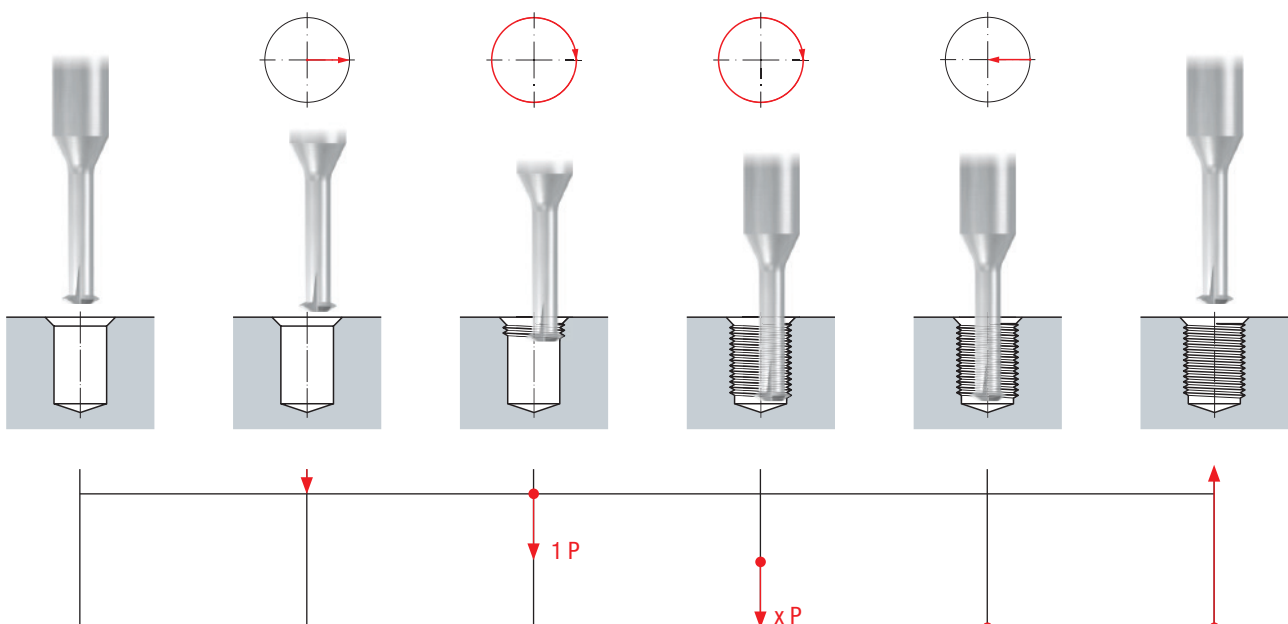

- Product Finder
- v_c / f_z
- M
- MF
- UNC
UN, UNS
- UNF
UNEF
- G, Rp
- NPT, NPTF
Rc, W
- BSW, BSF
- Pg
- EG (STI)
SELF-LOCK
- Tr
- Zubehör
Accessories
- Tech. Info
- BGF
- ZBGF
- GSF
- GF
- GF-KEG
- ZGF
- ZIRK-GF
- Gigant
- MoSys

M, MF

DIN 13

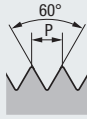

VHM

RH + LH

Z1 - Z5



DIN 6535



Für Innengewinde
For internal threads

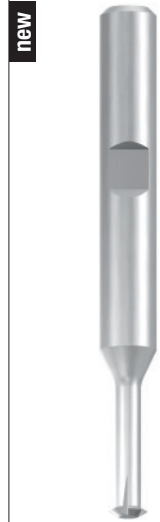
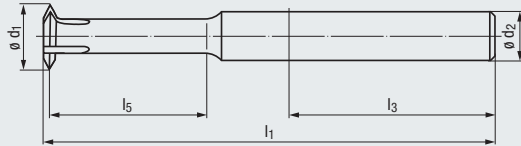

Gewindetiefe
Thread depth

2 x D

Einsatzgebiete – Material
Applications – material



P 1.1-5.1 K 1.1-4.2 N 1.1-5, 2.1-6
N 3.1-2 N 4.1-2, 5.2 S 1.1-3

Tech. Info

Ø D	P _{max.} mm	l ₁	l ₃	l ₅	Ø d ₁	Ø d ₂	Z	ZGF-VHM 2xD HA		ZGF-VHM 2xD HB	
								Part No.	Material	Part No.	Material
M1 - M1,2	0,25	39	28	2,8	0,7	3	1	GF243701.0010	●		
M1,4 - M1,8	0,35	39	28	3,5	1,04	3	2	GF253701.0014	●		
M2 - M2,3	0,45	39	28	4,8	1,52	3	3	GF253701.0020	●		
M2,5 - M3	0,5	39	28	6	1,95	3	3	GF253701.0025	●		
M3,5 - M4,5	0,75	42	28	9	2,78	4	3	GF253701.0035	●		
M5 - M7	1	55	36	14	4	6	4	GF253701.0050	●	GF253101.0050	●
M8 - M10 ¹⁾	1,5	62	36	19,8	6,5	8	5	GF253701.0080	●	GF253101.0080	●
M12 - M16 ¹⁾	2	78	40	31,8	9,9	10	5	GF253701.0112	●	GF253101.0112	●

Einsatzgebiete – Material
Applications – material



TICN



P 1.1-5.1 M 1.1-4.1 K 1.1-4.2
N 1.1-5.2 S 1.1-2.6 H 1.1-2

Ø D	P _{max.} mm	l ₁	l ₃	l ₅	Ø d ₁	Ø d ₂	Z	ZGF-VHM 2xD HA TICN		ZGF-VHM 2xD HB TICN	
								Part No.	Material	Part No.	Material
M1 - M1,2	0,25	39	28	2,8	0,7	3	1	GF243706.0010	●		
M1,4 - M1,8	0,35	39	28	3,5	1,04	3	2	GF253706.0014	●		
M2 - M2,3	0,45	39	28	4,8	1,52	3	3	GF253706.0020	●		
M2,5 - M3	0,5	39	28	6	1,95	3	3	GF253706.0025	●		
M3,5 - M4,5	0,75	42	28	9	2,78	4	3	GF253706.0035	●		
M5 - M7	1	55	36	14	4	6	4	GF253706.0050	●	GF253106.0050	●
M8 - M10 ¹⁾	1,5	62	36	19,8	6,5	8	5	GF253706.0080	●	GF253106.0080	●
M12 - M16 ¹⁾	2	78	40	31,8	9,9	10	5	GF253706.0112	●	GF253106.0112	●

¹⁾ Ausführung mit innerer Kühlschmierstoff-Zufuhr IKZ
Design with internal coolant supply IKZ

Teilweise auch für UN-Gewinde verwendbar
Partly suitable also for UN threads

Andere Ausführungen auf Anfrage
Other designs upon request

M, MF

DIN 13

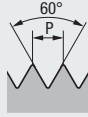

Für Innengewinde
For internal threads

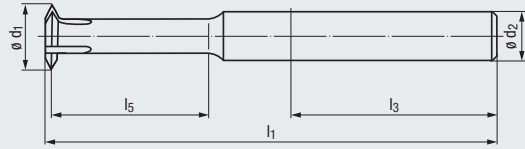

VHM

new

RH + LH

Z1 - Z5



DIN 6535



new



Gewindetiefe
Thread depth

3 x D

Einsatzgebiete – Material
Applications – material



P 1.1-5.1 K 1.1-4.2 N 1.1-5, 2.1-6
N 3.1-2 N 4.1-2, 5.2 S 1.1-3

ø D	P _{max.} mm	l ₁	l ₃	l ₅	ø d ₁	ø d ₂	Z	ZGF-VHM 3xD HA		ZGF-VHM 3xD HB	
								●	○	●	○
M1	0,25	39	28	3,1	0,7	3	1	GF273701.0010	●		
M1,6	0,35	39	28	4,95	1,18	3	2	GF273701.0016	●		
M2	0,4	39	28	6,2	1,52	3	3	GF273701.0020	●		
M2,5	0,45	39	28	7,7	1,96	3	3	GF273701.0025	●		
M3	0,5	41	28	9,25	2,4	3	3	GF273701.0030	●		
M4	0,7	44	28	12,35	3,15	4	3	GF273701.0040	●		
M5	0,8	56	36	15,4	4,04	6	4	GF273701.0050	●		
M6	1	59	36	18,5	4,8	6	4	GF273701.0060	●		
M8 ¹⁾	1,25	65	36	24,65	6,5	8	5	GF273701.0080	●		
M10 ¹⁾	1,5	77	40	30,75	8,2	10	5	GF273701.0100	●		
M12 ¹⁾	1,75	82	40	36,85	9,9	10	5	GF273701.0112	●		
M14 ¹⁾	2	94	45	43	11,6	12	5	GF273701.0114	●		
M16 ¹⁾	2	100	45	49	13,6	14	5	GF273701.0116	●		

Einsatzgebiete – Material
Applications – material



P 1.1-5.1 M 1.1-4.1 K 1.1-4.2
N 1.1-5.2 S 1.1-2.6 H 1.1-2

ø D	P _{max.} mm	l ₁	l ₃	l ₅	ø d ₁	ø d ₂	Z	ZGF-VHM 3xD HA TICN		ZGF-VHM 3xD HB TICN	
								●	○	●	○
M1	0,25	39	28	3,1	0,7	3	1	GF273706.0010	●		
M1,6	0,35	39	28	4,95	1,18	3	2	GF273706.0016	●		
M2	0,4	39	28	6,2	1,52	3	3	GF273706.0020	●		
M2,5	0,45	39	28	7,7	1,96	3	3	GF273706.0025	●		
M3	0,5	41	28	9,25	2,4	3	3	GF273706.0030	●		
M4	0,7	44	28	12,35	3,15	4	3	GF273706.0040	●		
M5	0,8	56	36	15,4	4,04	6	4	GF273706.0050	●	GF273106.0050	●
M6	1	59	36	18,5	4,8	6	4	GF273706.0060	●	GF273106.0060	●
M8 ¹⁾	1,25	65	36	24,65	6,5	8	5	GF273706.0080	●	GF273106.0080	●
M10 ¹⁾	1,5	77	40	30,75	8,2	10	5	GF273706.0100	●	GF273106.0100	●
M12 ¹⁾	1,75	82	40	36,85	9,9	10	5	GF273706.0112	●	GF273106.0112	●
M14 ¹⁾	2	94	45	43	11,6	12	5	GF273706.0114	●	GF273106.0114	●
M16 ¹⁾	2	100	45	49	13,6	14	5	GF273706.0116	●	GF273106.0116	●

¹⁾ Ausführung mit innerer Kühlschmierstoff-Zufuhr IKZ
Design with internal coolant supply IKZ

Teilweise auch für UN-Gewinde verwendbar
Partly suitable also for UN threads

Andere Ausführungen auf Anfrage
Other designs upon request

Product Finder

v_c / f_z

M

MF

UNC
UN, UNS

UNF
UNEF

G, Rp

NPT, NPTF
Rc, W

BSW, BSF

Pg

EG (STI)
SELF-LOCK

Tr

Zubehör
Accessories

Tech. Info

BGF

ZBGF

GSF

GF

GF-KEG

ZGF

ZIRK-GF

Gigant

MoSys



- Product Finder
- v_c / f_z
- M
- MF
- UNC
UN, UNS
- UNF
UNEF
- G, Rp
- NPT, NPTF
Rc, W
- BSW, BSF
- Pg
- EG (STI)
SELF-LOCK
- Tr
- Zubehör
Accessories
- Tech. Info
- BGF
- ZBGF
- GSF
- GF
- GF-KEG
- ZGF
- ZIRK-GF
- Gigant
- MoSys

M, MF

DIN 13

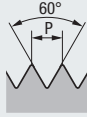

Für Innengewinde
For internal threads

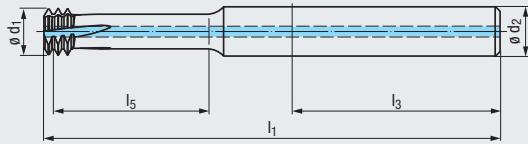

VHM	TIALN T46
RH + LH	LH-rot.
L10	Z4 - Z5
DIN 6535	ø D
HA	HB

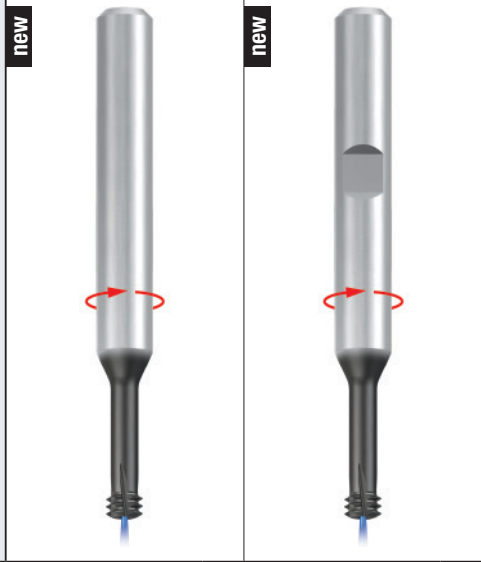

Gewindetiefe
Thread depth

2 x D

Einsatzgebiete – Material
Applications – material



P 1.1-5.1	M 1.1-4.1	K 1.1-4.2
N 1.1-5.2	S 1.1-2.6	H 1.1-2

ø D	P _{max.} mm	l ₁	l ₃	l ₅	ø d ₁	ø d ₂	Z
M 3 ²⁾	0,5	39	28	6,2	2,4	3	4
M 4 ²⁾	0,7	42	28	8,3	3,15	4	4
M 5	0,8	52	36	10,3	4,04	6	4
M 6	1	55	36	12,43	4,8	6	4
M 8	1,25	60	36	16,7	6,5	8	4
M10	1,5	70	40	20,7	8,2	10	5

ZGF-S-CUT-VHM 2xD IKZ-HA TIALN-T46	ZGF-S-CUT-VHM 2xD IKZ-HB TIALN-T46
GF26A729.0030	●
GF26A729.0040	●
GF26A729.0050	●
GF26A729.0060	●
GF26A729.0080	●
GF26A729.0100	●

²⁾ Ausführung ohne innerer Kühlschmierstoff-Zufuhr IKZ
Design without internal coolant supply IKZ

Andere Ausführungen auf Anfrage
Other designs upon request

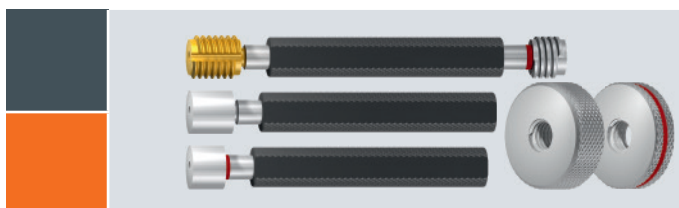

Gwindelehren
siehe Seite 581 - 654

Thread gauges,
see page 581 - 654

M, MF

DIN 13

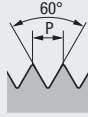

Für Innengewinde
For internal threads

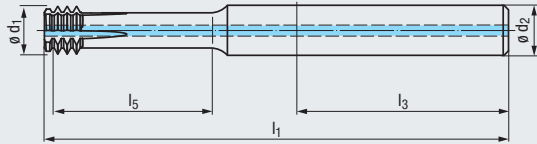

VHM **TIALN T46** **new**

RH + LH **LH-rot.**

Z4 - Z5

DIN 6535

HA HB

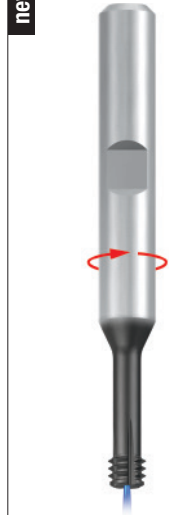

Gewindetiefe
Thread depth

2 x D

Einsatzgebiete – Material
Applications – material **328**

H 1.1-5

ø D	P _{max.} mm	l ₁	l ₃	l ₅	ø d ₁	ø d ₂	Z	ZGF-HCUT-VHM 2xD IKZ-HA TIALN-T46		ZGF-HCUT-VHM 2xD IKZ-HB TIALN-T46	
								●	●	●	●
M 3 ²⁾	0,5	51	36	6,25	2,4	6	4	●	●	●	●
M 4 ²⁾	0,7	51	36	8,35	3,15	6	4	●	●	●	●
M 5	0,8	52	36	10,4	4,04	6	4	●	●	●	●
M 6	1	55	36	12,3	4,8	6	4	●	●	●	●
M 8	1,25	60	36	16,6	6,5	8	4	●	●	●	●
M10	1,5	70	40	20,75	8,2	10	5	●	●	●	●
M12	1,75	74	40	24,85	9,9	10	5	●	●	●	●
M14	2	85	45	29	11,6	12	5	●	●	●	●
M16	2	90	45	33	13,6	14	5	●	●	●	●

²⁾ Ausführung ohne innerer Kühlschmierstoff-Zufuhr IKZ
Design without internal coolant supply IKZ

Andere Ausführungen auf Anfrage
Other designs upon request

Product Finder

v_c / f_z

M

MF

UNC UN, UNS

UNF UNEF

G, Rp

NPT, NPTF Rc, W

BSW, BSF

Pg

EG (STI) SELF-LOCK

Tr

Zubehör Accessories

Tech. Info

BGF

ZBGF

GSF

GF

GF-KEG

ZGF

ZIRK-GF

Gigant

MoSys

- Product Finder
- v_c / f_z
- M
- MF
- UNC
UN, UNS
- UNF
UNEF
- G, Rp
- NPT, NPTF
Rc, W
- BSW, BSF
- Pg
- EG (STI)
SELF-LOCK
- Tr
- Zubehör
Accessories
- Tech. Info
- BGF
- ZBGF
- GSF
- GF
- GF-KEG
- ZGF
- ZIRK-GF
- Gigant
- MoSys

UNC, UNF

ASME B1.1

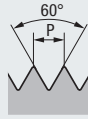

Für Innengewinde
For internal threads

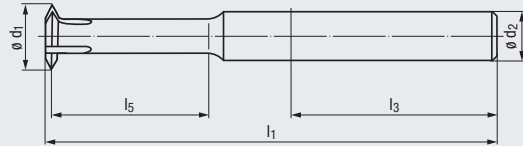

VHM

RH + LH

Z3

DIN 6535

HA

$\varnothing D$

new



Gewindetiefe
Thread depth

2 x D

Einsatzgebiete – Material
Applications – material

» 328

- P 1.1-5.1
- K 1.1-4.2
- N 1.1-5, 2.1-6
- N 3.1-2
- N 4.1-2, 5.2
- S 1.1-3

$\varnothing D$	$P_{max.}$ mm	l_1	l_3	l_5	$\varnothing d_1$	$\varnothing d_2$	Z	ZGF-VHM 2xD HA
Nr. 4 - 40	0,635	39	28	6,35	2,06	3	3	GF253701.5003
Nr. 6 - 32	0,794	39	28	7	2,55	3	3	GF253701.5005
Nr. 8 - 32	0,794	42	28	8,35	3,21	4	3	GF253701.5006

Einsatzgebiete – Material
Applications – material

» 328

TICN

new



$\varnothing D$	$P_{max.}$ mm	l_1	l_3	l_5	$\varnothing d_1$	$\varnothing d_2$	Z	ZGF-VHM 2xD HA TICN
Nr. 4 - 40	0,635	39	28	6,35	2,06	3	3	GF253706.5003
Nr. 6 - 32	0,794	39	28	7	2,55	3	3	GF253706.5005
Nr. 8 - 32	0,794	42	28	8,35	3,21	4	3	GF253706.5006

Auch für UNF-Gewinde verwendbar
Suitable also for UNF threads

Andere Ausführungen auf Anfrage
Other designs upon request

UNC

ASME B1.1

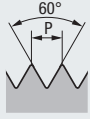

Für Innengewinde
For internal threads

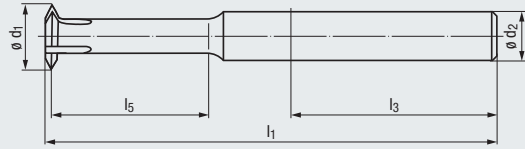

VHM **TICN** **new**

RH + LH

Z3 - Z5 **DIN 6535**

HA HB

ø D



Gewindetiefe
Thread depth

3 x D

Einsatzgebiete – Material
Applications – material

P 1.1-5.1 **M** 1.1-4.1 **K** 1.1-4.2
N 1.1-5.2 **S** 1.1-2.6 **H** 1.1-2

ø D	P _{max.} mm	l ₁	l ₃	l ₅	ø d ₁	ø d ₂	Z	ZGF-VHM 3xD HA TICN	ZGF-VHM 3xD HB TICN
Nr. 2 - 56	0,454	39	28	6,75	1,7	3	3	GF273706.5001	●
Nr. 4 - 40	0,635	40	28	8,85	2,15	3	3	GF273706.5003	●
Nr. 6 - 32	0,794	42	28	10,9	2,7	3	3	GF273706.5005	●
Nr. 10 - 24	1,058	46	28	15	3,7	4	3	GF273706.5007	●
1/4 - 20	1,27	59	36	20,15	4,95	6	4	GF273706.5009	● GF273106.5009 ●
5/16 - 18¹⁾	1,411	65	36	24,5	6,3	8	4	GF273706.5010	● GF273106.5010 ●
3/8 - 16¹⁾	1,588	68	36	29,38	7,7	8	5	GF273706.5011	● GF273106.5011 ●

UNF

ASME B1.1



Einsatzgebiete – Material
Applications – material

P 1.1-5.1 **M** 1.1-4.1 **K** 1.1-4.2
N 1.1-5.2 **S** 1.1-2.6 **H** 1.1-2

ø D	P _{max.} mm	l ₁	l ₃	l ₅	ø d ₁	ø d ₂	Z	ZGF-VHM 3xD HA TICN	ZGF-VHM 3xD HB TICN
Nr. 10 - 32	0,794	46	28	14,85	3,9	4	4	GF273706.5041	●
1/4 - 28	0,907	59	36	19,5	5,25	6	4	GF273706.5043	● GF273106.5043 ●
5/16 - 24¹⁾	1,058	65	36	24,3	6,6	8	5	GF273706.5044	● GF273106.5044 ●
7/16 - 20¹⁾	1,27	77	40	33,95	9,55	10	5	GF273706.5046	● GF273106.5046 ●

¹⁾ Ausführung mit innerer Kühlschmierstoff-Zufuhr IKZ
Design with internal coolant supply IKZ

Teilweise auch für Metrische Gewinde verwendbar
Partly suitable also for Metric threads

Andere Ausführungen auf Anfrage
Other designs upon request

Product Finder

v_c / f_z

M

MF

UNC
UN, UNS

UNF
UNEF

G, Rp

NPT, NPTF
Rc, W

BSW, BSF

Pg

EG (STI)
SELF-LOCK

Tr

Zubehör
Accessories

Tech. Info

BGF

ZBGF

GSF

GF

GF-KEG

ZGF

ZIRK-GF

Gigant

MoSys

- Product Finder
- v_c / f_z
- M
- MF
- UNC
UN, UNS
- UNF
UNEF
- G, Rp
- NPT, NPTF
Rc, W
- BSW, BSF
- Pg
- EG (STI)
SELF-LOCK
- Tr
- Zubehör
Accessories
- Tech. Info
- BGF
- ZBGF
- GSF
- GF
- GF-KEG
- ZGF
- ZIRK-GF
- Gigant
- MoSys

UNC

ASME B1.1



Für Innengewinde
For internal threads

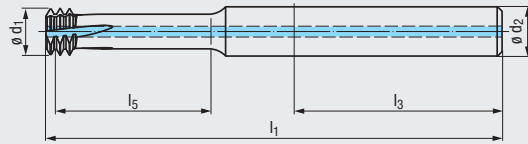

VHM
TIALN T46

RH + LH
LH-rot.

L10

DIN 6535

HA
 HB

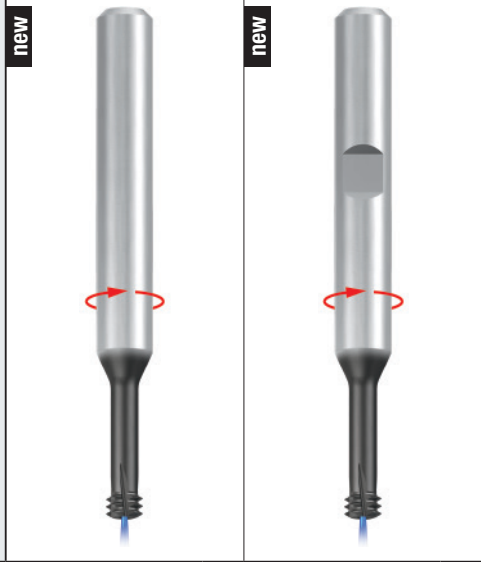

Gewindetiefe
Thread depth

2 x D

Einsatzgebiete – Material
Applications – material



P 1.1-5.1	M 1.1-4.1	K 1.1-4.2
N 1.1-5.2	S 1.1-2.6	H 1.1-2

	$\varnothing D$	$P_{max.}$ mm	l_1	l_3	l_5	$\varnothing d_1$	$\varnothing d_2$	Z
Nr. 4 - 40²⁾		0,635	39	28	5,95	2,15	3	3
Nr. 6 - 32²⁾		0,794	39	28	7,3	2,7	3	3
Nr. 10 - 24²⁾		1,058	42	28	10,1	3,7	4	3
1/4 - 20		1,27	55	36	13,2	4,95	6	3
5/16 - 18		1,411	58	36	16,45	6,3	8	4
3/8 - 16		1,588	62	36	16,65	7,7	8	4

ZGF-S-CUT-VHM 2xD IKZ-HA TIALN-T46	ZGF-S-CUT-VHM 2xD IKZ-HB TIALN-T46
GF26A729.5003	●
GF26A729.5005	●
GF26A729.5007	●
GF26A729.5009	● GF26A129.5009 ●
GF26A729.5010	● GF26A129.5010 ●
GF26A729.5011	● GF26A129.5011 ●

UNF

ASME B1.1



Einsatzgebiete – Material
Applications – material

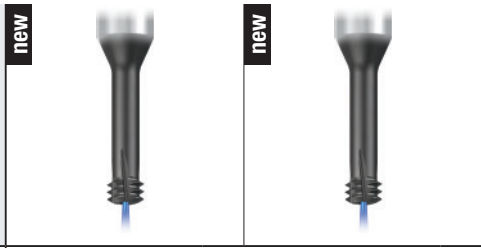

	$\varnothing D$	$P_{max.}$ mm	l_1	l_3	l_5	$\varnothing d_1$	$\varnothing d_2$	Z
Nr. 10 - 32²⁾		0,794	42	28	9,95	3,9	4	4
1/4 - 28		0,907	55	36	13,1	5,25	6	5
5/16 - 24		1,058	58	36	16,3	6,6	8	5
7/16 - 20		1,27	74	40	22,75	9,55	10	6

ZGF-S-CUT-VHM 2xD IKZ-HA TIALN-T46	ZGF-S-CUT-VHM 2xD IKZ-HB TIALN-T46
GF26A729.5041	●
GF26A729.5043	● GF26A129.5043 ●
GF26A729.5044	● GF26A129.5044 ●
GF26A729.5046	● GF26A129.5046 ●

²⁾ Ausführung ohne innerer Kühlschmierstoff-Zufuhr IKZ
Design without internal coolant supply IKZ

Andere Ausführungen auf Anfrage
Other designs upon request

Zirkular-Gewindefräskörper mit einer Fräsplatte 15 mm
Circular thread milling bodies with 1 insert 15 mm

ZIRK-GF

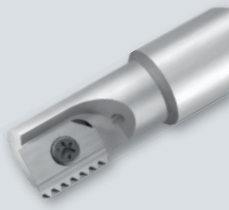

Zirkular-Gewindefräskörper mit zwei Fräsplatten 15 mm
Circular thread milling bodies with 2 inserts 15 mm

ZIRK-GF

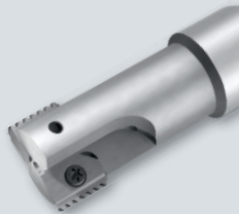

Zirkular-Gewindefräskörper mit einer Fräsplatte 26 mm
Circular thread milling bodies with 1 insert 26 mm

ZIRK-GF



Zirkular-Gewindefräskörper mit Einstechwendeplatte „3-Zahn“
Circular thread milling bodies with indexable infeed insert „3-tooth“

ZIRK-GF¹⁾

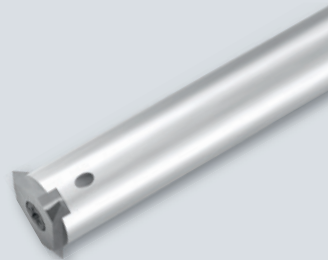

Seite · Page

422

422

424

425

Standard-Fräsplatten 15 mm
Standard inserts 15 mm

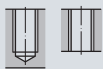
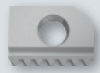

Lange Fräsplatten 26 mm
Long inserts 26 mm

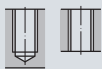

Einstechwendeplatten „3-Zahn“
Indexable infeed inserts, „3-tooth“ design

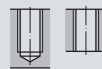
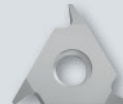

Seite · Page

423

424

425

M, MF

423

UN

423

423

424

424

425

425

G (BSP), BSW, BSF, W

Product Finder

v_c / f_z

M

MF

UNC
UN, UNS

UNF
UNEF

G, Rp

NPT, NPTF
Rc, W

BSW, BSF

Pg

EG (STI)
SELF-LOCK

Tr

Zubehör
Accessories

Tech. Info

BGF

ZBGF

GSF

GF

GF-KEG

ZGF

ZIRK-GF

Gigant

MoSys



¹⁾ Gewindefräszyklus „3-Zahn“ entspricht der Ausführung Gigant, siehe Seite 426
Thread milling cycle corresponding to that of the Gigant design, see page 426

Gewindefräszyklus · Thread milling cycle

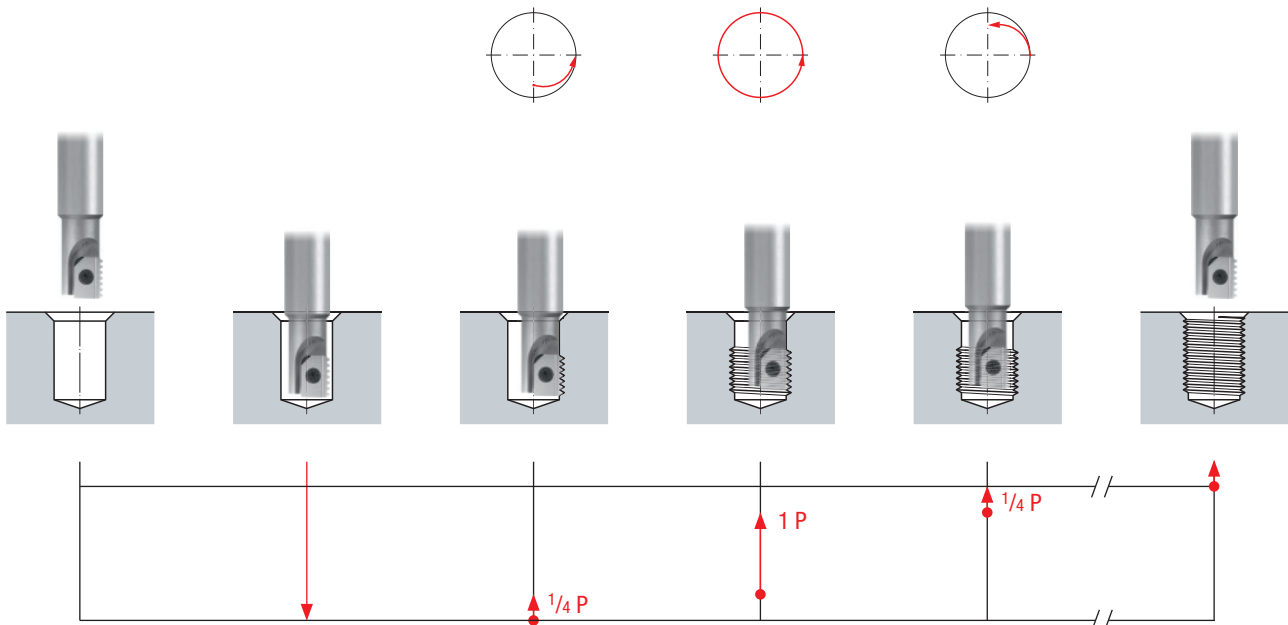

Product Finder

v_c / f_z

M

MF

UNC
UN, UNS

UNF
UNEF

G Rp

NPT, NPTF
Rc, W

BSW, BSF

Pg

EG (STI)
SELF-LOCK

Tr

Zubehör
Accessories

Tech. Info

BGF

ZBGF

GSF

GF

GF-KEG

ZGF

ZIRK-GF

Gigant

MoSys

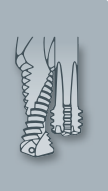

Ausführung für eine Standard-Fräsplatte 15 mm Design for 1 standard insert 15 mm

DIN 1835



Kurze Ausführung Short design

P mm	l_1	l_2	l_3	l_5	$\varnothing d_1$	$\varnothing d_2$ h6	$\varnothing d_3$	ZIRK-GF 15 mm-Z1 IKZN	
0,5 - 2,5	78	15	48	30	16	16	13	GZ301110	●

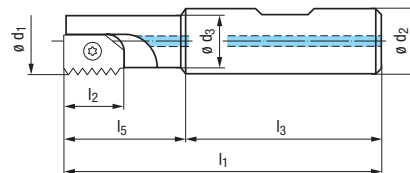

Lange Ausführung Long design

P mm	l_1	l_2	l_3	l_5	$\varnothing d_1$	$\varnothing d_2$ h6	$\varnothing d_3$	ZIRK-GF 15 mm-Z1 IKZN	
0,5 - 2,5	98	15	48	50	16	16	13	GZ301310 ²⁾	●
0,5 - 2,5	110	15	50	60	20	20	17	GZ301320	●
3,0 - 3,5 ¹⁾	110	15	50	60	22	20	17	GZ301340	●

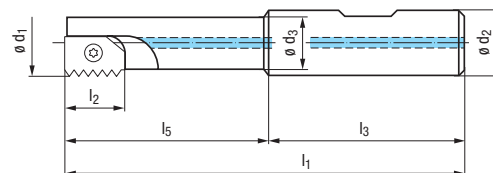

Ausführung für zwei Standard-Fräsplatten 15 mm Design for 2 standard inserts 15 mm

DIN 1835



Kurze Ausführung Short design

P mm	l_1	l_2	l_3	l_5	$\varnothing d_1$	$\varnothing d_2$ h6	$\varnothing d_3$	ZIRK-GF 15 mm-Z2 IKZN	
0,5 - 2,5	106	15	56	50	25	25	21	GZ301130	●
3,0 - 3,5 ¹⁾	106	15	56	50	27	25	21	GZ301140	●

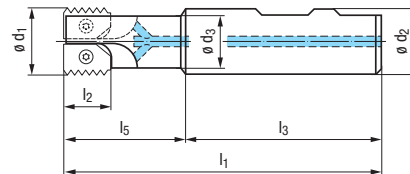

Lange Ausführung Long design

P mm	l_1	l_2	l_3	l_5	$\varnothing d_1$	$\varnothing d_2$ h6	$\varnothing d_3$	ZIRK-GF 15 mm-Z2 IKZN	
0,5 - 2,5	150	15	56	94	25	25	21	GZ301330 ²⁾	●

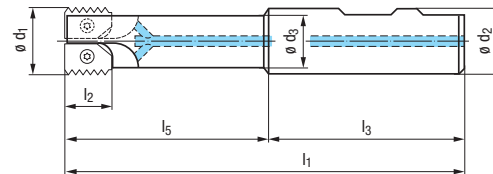

¹⁾ Verstärkte Ausführung
Reinforced design

²⁾ Aus Schwermetall, schwingungsgedämpft
Of vibration-absorbing heavy metal

M, MF

DIN 13

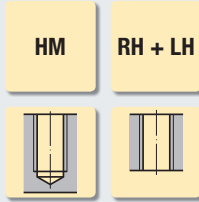
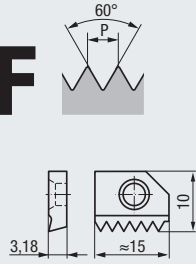

Für Innengewinde
For internal threads

Standard-Fräsplatten 15 mm
Standard inserts 15 mm



Beschichtung · Coating

TIALN-T4

Einsatzgebiete – Material
Applications – material

» 328

P 1.1-5.1	K 1.1-4.2	N 1.1-5	P 1.1-5.1	M 1.1-4.1	K 1.1-4.2
N 2.1-6	N 3.1-4.2, 5.2	S 1.1-3	N 1.1-5.2	S 1.1-2.6	H 1.1-2

P
mm

HM-FP-Z1
15 mm

HM-FP-Z1
15 mm
TIALN-T4

P mm	GF603111.9506		GF603117.9506	
0,5	●		●	
0,75	●		●	
1	●		●	
1,25	●		●	
1,5	●		●	
1,75	●		●	
2	●		●	
2,5	●		●	
3 ¹⁾	●		●	
3,5 ¹⁾	●		●	

UN

ANSI B1.1

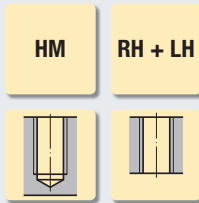
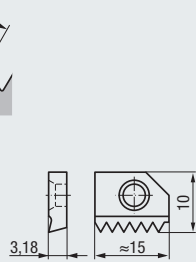

Für Innengewinde
For internal threads

Standard-Fräsplatten 15 mm
Standard inserts 15 mm



Beschichtung · Coating

TIALN-T4

Einsatzgebiete – Material
Applications – material

» 328

P 1.1-5.1	K 1.1-4.2	N 1.1-5	P 1.1-5.1	M 1.1-4.1	K 1.1-4.2
N 2.1-6	N 3.1-4.2, 5.2	S 1.1-3	N 1.1-5.2	S 1.1-2.6	H 1.1-2

P
Gg/1" (tpi)

HM-FP-Z1
15 mm

HM-FP-Z1
15 mm
TIALN-T4

P Gg/1" (tpi)	GF603111.9580		GF603117.9580	
20	●		●	
16	●		●	
14	●		●	
12	●		●	

G (BSP), BSW, BSF, W

DIN EN ISO 228, BS 84

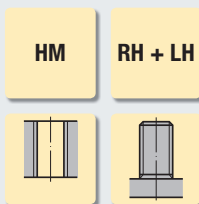
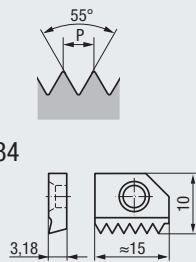

Für Innen- und Außengewinde
For internal and external threads

Standard-Fräsplatten 15 mm
Standard inserts 15 mm



Beschichtung · Coating

TIALN-T4

Einsatzgebiete – Material
Applications – material

» 328

P 1.1-5.1	K 1.1-4.2	N 1.1-5	P 1.1-5.1	M 1.1-4.1	K 1.1-4.2
N 2.1-6	N 3.1-4.2, 5.2	S 1.1-3	N 1.1-5.2	S 1.1-2.6	H 1.1-2

P
Gg/1" (tpi)

HM-FP-Z1
15 mm

HM-FP-Z1
15 mm
TIALN-T4

P Gg/1" (tpi)	GF603111.9548		GF603117.9548	
14	●		●	
11	●		●	

Ersatzschraube M4 x 7; Torx T15 } **GZ309010**
Spare screw M4 x 7; Torx T15

Schraubendreher Torx T15 } **GZ309020**
Screw driver Torx T15

Product Finder

v_c / f_z

M

MF

UNC
UN, UNS

UNF
UNEF

G, Rp

NPT, NPTF
Rc, W

BSW, BSF

Pg

EG (STI)
SELF-LOCK

Tr

Zubehör
Accessories

Tech. Info

BGF

ZBGF

GSF

GF

GF-KEG

ZGF

ZIRK-GF

Gigant

MoSys

Product Finder

v_c / f_z

M

MF

UNC
UN, UNS

UNF
UNEF

G Rp

NPT, NPTF
Rc, W

BSW, BSF

Pg

EG (STI)
SELF-LOCK

Tr

Zubehör
Accessories

Tech. Info

BGF

ZBGF

GSF

GF

GF-KEG

ZGF

ZIRK-GF

Gigant

MoSys



Ausführung für eine lange Fräsplatte 26 mm
Design for 1 long insert 26 mm

DIN 1835



Kurze Ausführung
Short design

P mm	l_1	l_2	l_3	l_5	$\varnothing d_1$	$\varnothing d_2$ h6	$\varnothing d_3$	ZIRK-GF 26 mm-Z1 IKZN
1 - 4	107	26	56	48	25	25	20	GZ303010 ●

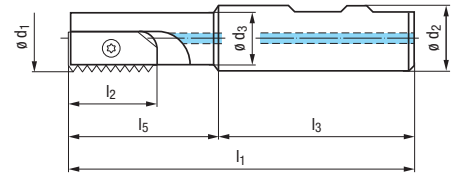

M, MF
DIN 13

HM **RH + LH**

Für Innengewinde
For internal threads

Lange Fräsplatten 26 mm
Long inserts 26 mm



Beschichtung · Coating

TIALN-T4

Einsatzgebiete – Material
Applications – material



P 1.1-5.1	K 1.1-4.2	N 1.1-5	P 1.1-5.1	M 1.1-4.1	K 1.1-4.2
N 2.1-6	N 3.1-4.2, 5.2	S 1.1-3	N 1.1-5.2	S 1.1-2.6	H 1.1-2

P mm

HM-FP-Z1
26 mm

HM-FP-Z1
26 mm
TIALN-T4

1	GF603142.9512	●	GF603147.9514	●
1,5	GF603142.9514	●	GF603147.9514	●
2	GF603142.9516	●	GF603147.9516	●
2,5	GF603142.9517	●	GF603147.9517	●
3	GF603142.9518	●	GF603147.9518	●
3,5	GF603142.9519	●	GF603147.9519	●
4	GF603142.9520	●	GF603147.9520	●

G (BSP), BSW, BSF, W
DIN EN ISO 228, BS 84

HM **RH + LH**

Für Innen- und Außengewinde
For internal and external threads

Lange Fräsplatten 26 mm
Long inserts 26 mm



Beschichtung · Coating

TIALN-T4

Einsatzgebiete – Material
Applications – material



P 1.1-5.1	K 1.1-4.2	N 1.1-5	P 1.1-5.1	M 1.1-4.1	K 1.1-4.2
N 2.1-6	N 3.1-4.2, 5.2	S 1.1-3	N 1.1-5.2	S 1.1-2.6	H 1.1-2

P Gg/1" (tpi)

HM-FP-Z1
26 mm

HM-FP-Z1
26 mm
TIALN-T4

14	GF603142.9548	●	GF603147.9548	●
11	GF603142.9550	●	GF603147.9550	●

Ersatzschraube M4 x 13; Torx T15
Spare screw M4 x 13; Torx T15 } **GZ309210**

Schraubendreher Torx T15
Screw driver Torx T15 } **GZ309020**

Für Einstechwendeplatten „3-Zahn“
For indexable infeed inserts, “3-tooth” design

DIN 6535

HB

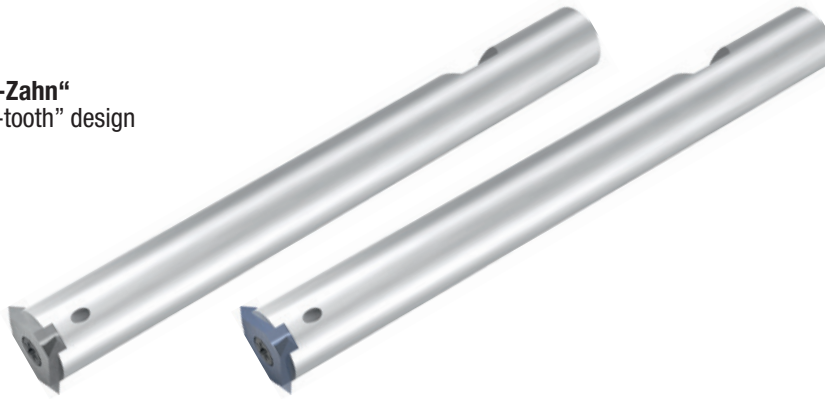

Hartmetall-Ausführung
Carbide design

Plattengröße Insert size	l_1	l_3	l_5	$\varnothing d_2$ h6	ZIRK-GF Gr. 02 IKZN
02	112	45	67	12	GZ311330 ●

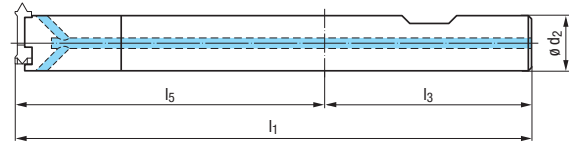

M, MF
DIN 13

HM **RH + LH**

Für Innengewinde
For internal threads

Einstechwendeplatten „3-Zahn“
Indexable infeed inserts, “3-tooth” design



Beschichtung · Coating

TIALN-T4

Einsatzgebiete – Material
Applications – material

P 1.1-5.1 **K 1.1-4.2** **N 1.1-5** **P 1.1-5.1** **M 1.1-4.1** **K 1.1-4.2**
N 2.1-6 **N 3.1-4.2, 5.2** **S 1.1-3** **N 1.1-5.2** **S 1.1-2.6** **H 1.1-2**

Plattengröße
Insert size

HM-EP-Z3
Gr. 02

HM-EP-Z3
Gr. 02
TIALN-T4

P mm

$\varnothing D$

02	1 - 3,5	17,5
02	3	17,5

GF613121.9512	●
GF613121.9518	●

GF613127.9512	●
GF613127.9518	●

02	2,5 (M20)	16
----	-----------	----

GF613121.0120	●
----------------------	---

GF613127.0120	●
----------------------	---

**G (BSP),
BSW, BSF, W**
DIN EN ISO 228, BS 84

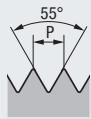

HM

RH + LH

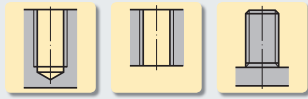

Einstechwendeplatten „3-Zahn“
Indexable infeed inserts, “3-tooth” design



Beschichtung · Coating

TIALN-T4

Einsatzgebiete – Material
Applications – material

P 1.1-5.1 **K 1.1-4.2** **N 1.1-5** **P 1.1-5.1** **M 1.1-4.1** **K 1.1-4.2**
N 2.1-6 **N 3.1-4.2, 5.2** **S 1.1-3** **N 1.1-5.2** **S 1.1-2.6** **H 1.1-2**

Plattengröße
Insert size

HM-EP-Z3
Gr. 02

HM-EP-Z3
Gr. 02
TIALN-T4

P Gg/1" (tpi)

$\varnothing D$

02	14	17,5
02	11	17,5

GF613121.9548	●
GF613121.9550	●

GF613127.9548	●
GF613127.9550	●

Ersatzschraube M4 x 11; Torx T15 } **GZ319020**
Spare screw M4 x 11; Torx T15

Schraubendreher Torx T15 } **GZ319060**
Screw driver Torx T15

Product Finder

v_c / f_z

M

MF

UNC
UN, UNS

UNF
UNEF

G, Rp

NPT, NPTF
Rc, W

BSW, BSF

Pg

EG (STI)
SELF-LOCK

Tr

Zubehör
Accessories

Tech. Info

BGF

ZBGF

GSF

GF

GF-KEG

ZGF

ZIRK-GF

Gigant

MoSys

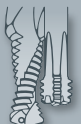

Product Finder

v_c / f_z

M

MF

UNC
UN, UNS

UNF
UNEF

G, Rp

NPT, NPTF
Rc, W

BSW, BSF

Pg

EG (STI)
SELF-LOCK

Tr

Zubehör
Accessories

Tech. Info

BGF

ZBGF

GSF

GF

GF-KEG

ZGF

ZIRK-GF

Gigant

MoSys

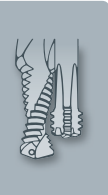

Werkzeugbeschreibung:

Zirkulargewindefräser mit auswechselbaren Wendeschneidplatten zur Herstellung von großen Innen- und Außengewinden (ab M20). Die Gewindefräsplatten können meist universell (steigungsübergreifend) eingesetzt werden. Voraussetzung ist ein vorgearbeitetes Kernloch und ggf. eine Ansenkung.

Einsatzgebiete:

Niedrig- und hochlegierte Stähle bis 1400 N/mm², nichtrostende Stahlwerkstoffe, Gusswerkstoffe, Aluminium-Legierungen, Kupfer-Legierungen, Magnesium-Legierungen, Kunststoffe sowie Titan-Legierungen.

Tool description:

Circular thread milling bodies with exchangeable inserts for the production of large internal and external threads (from M20). The inserts can mostly be used universally (they are not limited to a single pitch). A ready prepared thread hole, countersunk if necessary, is needed.

Application range:

Low- and high-alloyed steels up to 1400 N/mm², stainless steel materials, cast materials, aluminium alloys, copper alloys, magnesium alloys, synthetics as well as titanium alloys.

Gewindefräszyklus · Thread milling cycle

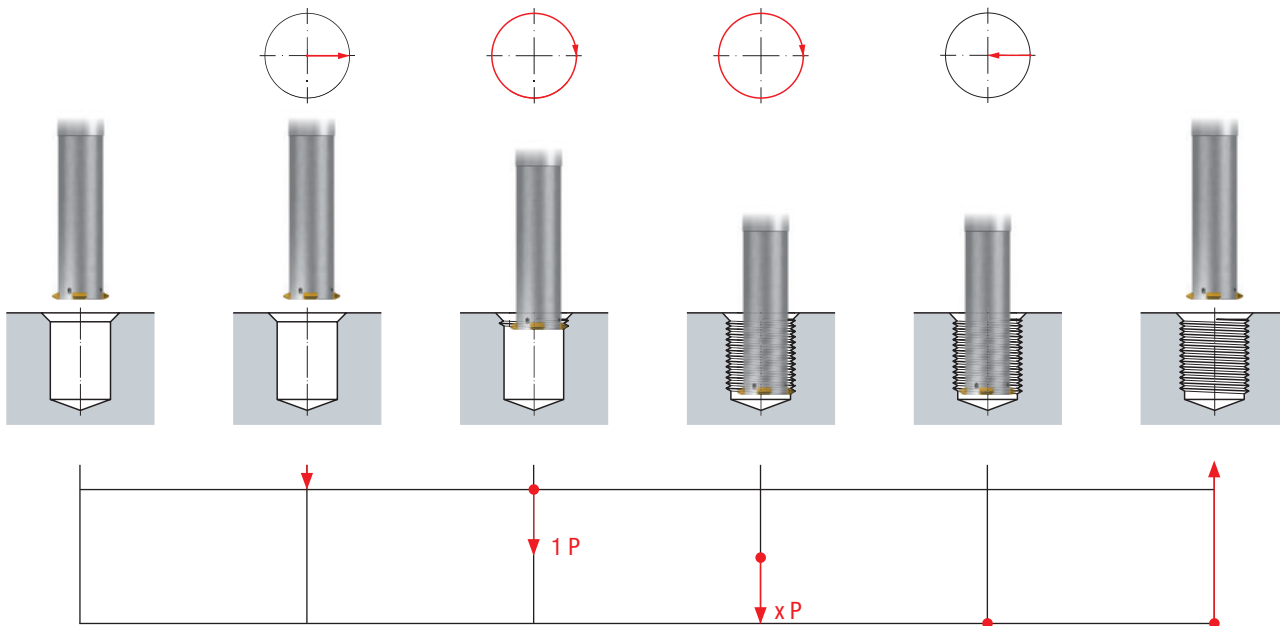

Gewindefräszyklus · Thread milling cycle

Gigant modular sprinter

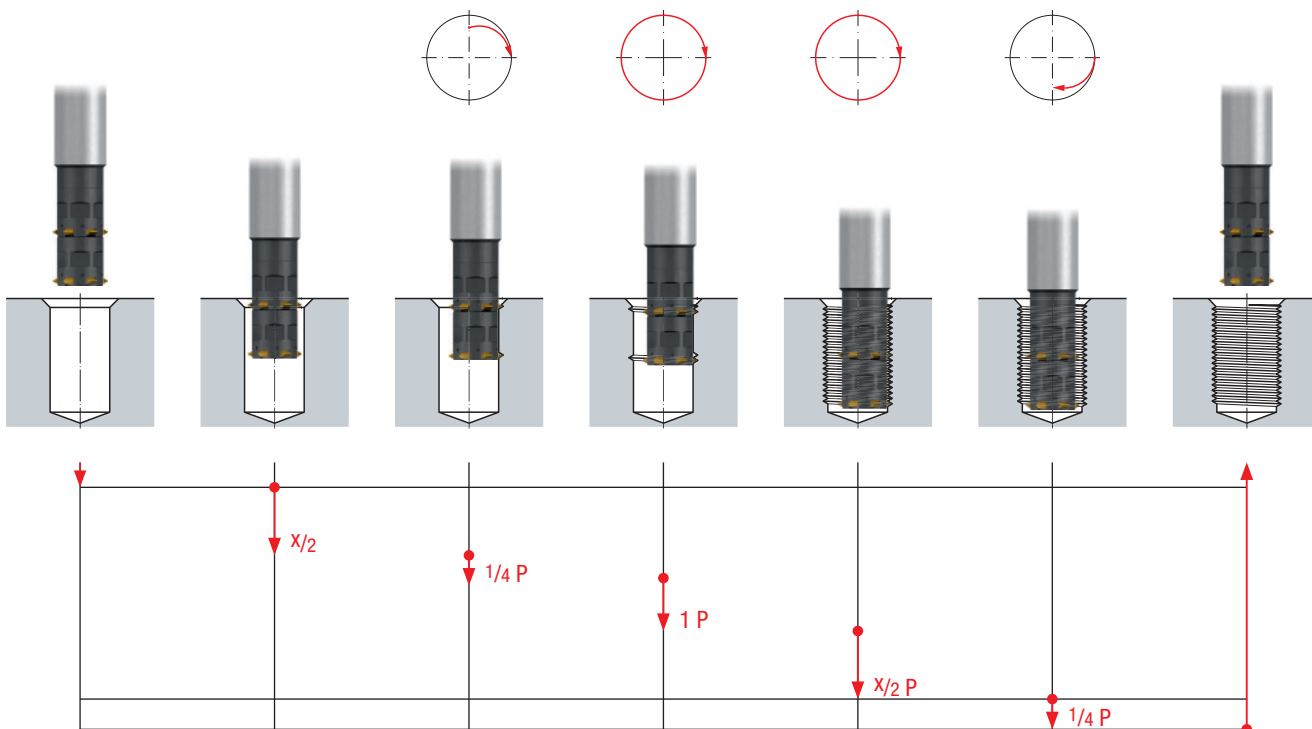

≥ 20 mm	≥ 30 mm	≥ 40 mm	≥ 48 mm	≥ 64 mm	≥ 115 mm
Größe Size	Größe Size	Größe Size	Größe Size	Größe Size	Größe Size
10	11	12	13	14	15

Seite · Page

430	432	434	436	438	440
-----	-----	-----	-----	-----	-----

≤ 3 mm (8 tpi)	≤ 4 mm (6 tpi)	$\leq 5,5$ mm (4.5 tpi)	≤ 6 mm (4 tpi)	≤ 8 mm (3.5 tpi)	≤ 12 mm (4 tpi)
Größe Size	Größe Size	Größe Size	Größe Size	Größe Size	Größe Size
10	11	12	13	14	15

Seite · Page

431	431	433	433	435	435	437	437	439	439	441	
431		433		435		437		439		441	
431	431	433	433	435	435	437	437	439	439		
		433		435							
431	431	433	433	435	435	437	437	439	439	441	441

Seite · Page

	Fräsringe zum Entfernen des unvollständigen Ganges Milling rings for removal of the incomplete thread	442
	Aufnahmen für Gigant Holders for Gigant	444 - 445

Product Finder

v_c / f_z

M

MF

UNC
UN, UNS

UNF
UNEF

G, Rp

NPT, NPTF
Rc, W

BSW, BSF

Pg

EG (STI)
SELF-LOCK

Tr

Zubehör
Accessories

Tech. Info

BGF

ZBGF

GSF

GF

GF-KEG

ZGF

ZIRK-GF

Gigant

MoSys



M, MF
UN
G (BSP), BSW, BSF, W
NPT
Tr

- Product Finder
- v_c / f_z
- M
- MF
- UNC
UN, UNS
- UNF
UNEF
- G, Rp
- NPT, NPTF
Rc, W
- BSW, BSF
- Pg
- EG (STI)
SELF-LOCK
- Tr
- Zubehör
Accessories
- Tech. Info
- BGF
- ZBGF
- GSF
- GF
- GF-KEG
- ZGF
- ZIRK-GF
- Gigant**
- MoSys
- 

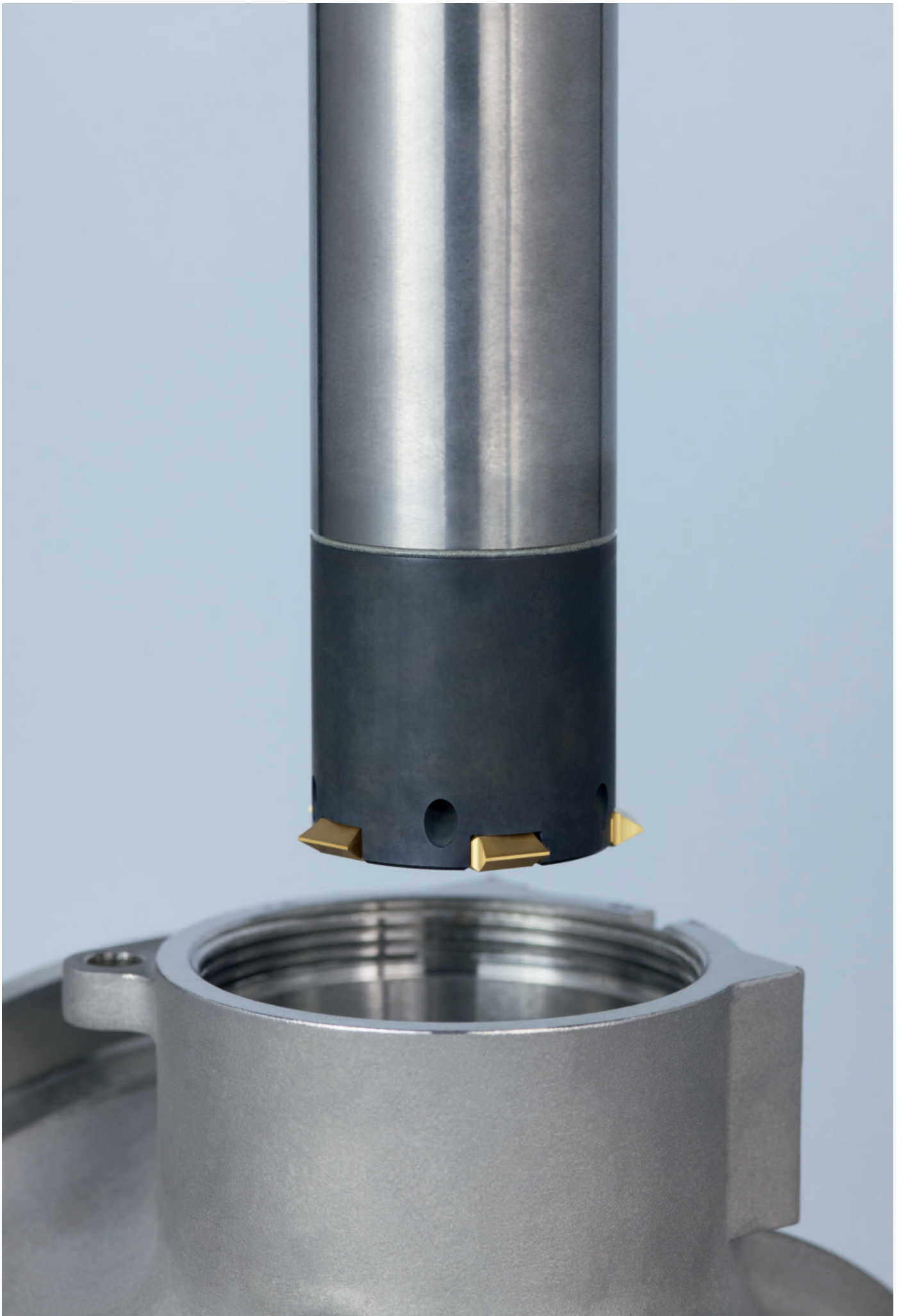

Gigant-ic

Vorteile:

- Flexibilität

Advantages:

- Flexibility

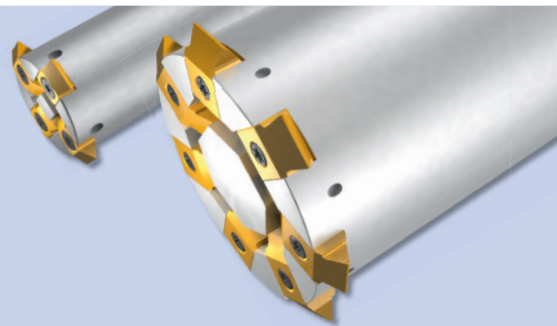

Gigant sprinter

Vorteile:

- Schnelligkeit

Advantages:

- Fast operation

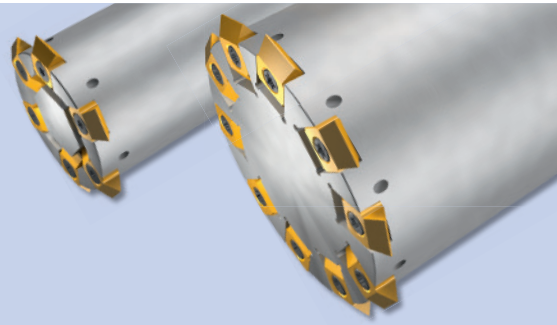

Gigant soft run

Hartmetall-Träger

Carbide tool body

Vorteile:

- Laufruhe
- Stabilität

Advantages:

- Smooth operation
- Stability

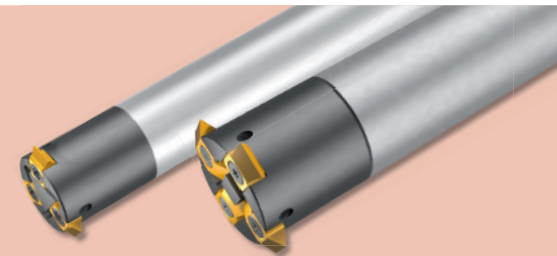

Gigant soft run sprinter

Hartmetall-Träger

Carbide tool body

Vorteile:

- Schnelligkeit
- Laufruhe
- Stabilität

Advantages:

- Fast operation
- Smooth operation
- Stability

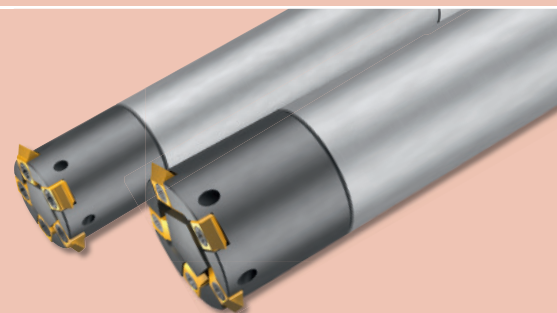

Gigant modular

Vorteile:

- Modularer Aufbau

Advantages:

- Modular construction

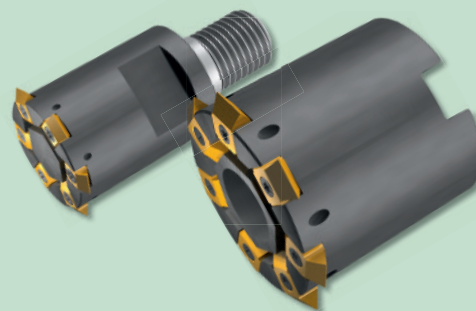

Gigant modular sprinter

Vorteile:

- Flexible Längen
- Kürzere Bearbeitungszeit

Advantages:

- Flexible lengths
- Reduced machining times

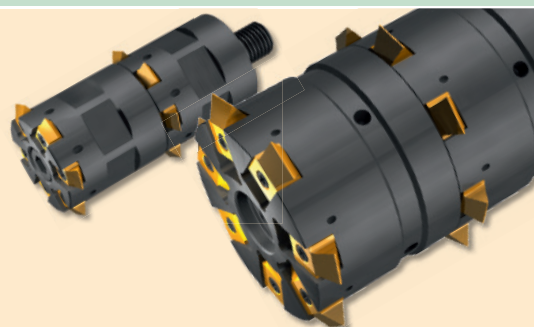

Product Finder

v_c / f_z

M

MF

UNC
UN, UNS

UNF
UNEF

G, Rp

NPT, NPTF
Rc, W

BSW, BSF

Pg

EG (STI)
SELF-LOCK

Tr

Zubehör
Accessories

Tech. Info

BGF

ZBGF

GSF

GF

GF-KEG

ZGF

ZIRK-GF

Gigant

MoSys

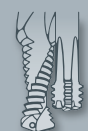

Product Finder

v_c / f_z

10

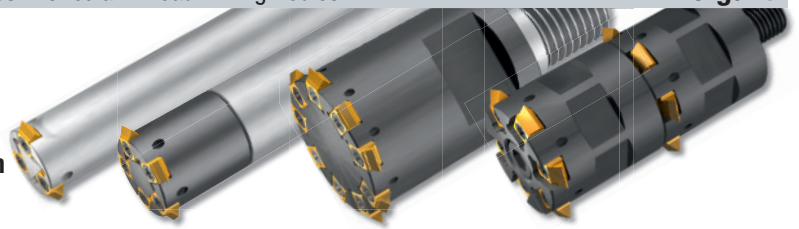

M

Für große Abmessungen ab Gewindedurchmesser 20 mm
For large thread sizes, from thread diameter 20 mm

MF

UNC
UN, UNS

UNF
UNEF

G Rp

NPT, NPTF
Rc, W

BSW, BSF

Pg

EG (STI)
SELF-LOCK

Tr

Zubehör
Accessories

Tech. Info

BGF

ZBGF

GSF

GF

GF-KEG

ZGF

ZIRK-GF

Gigant

MoSys



Gigant-ic

Gigant sprinter

DIN 1835 B



Z2 - Z3



Z5



$\varnothing D_{min.}$ mm	l_1	l_3	l_5	$\varnothing d_1$	$\varnothing d_2$ h6	$\varnothing d_5$	Z (Inserts)	Gigant-ic		Gigant sprinter	
								Gr. 10-1KZN		Gr. 10-1KZN	
20	87	45	40	17	12	12	2	GZ341000	●		
24	100	48	50	20,5	16	15,9	3	GZ341040	●		
24	115	48	65	20,5	16	15,9	3	GZ341050	●		
30	145	60	80	23,85	32	19	5			GZ341200	●

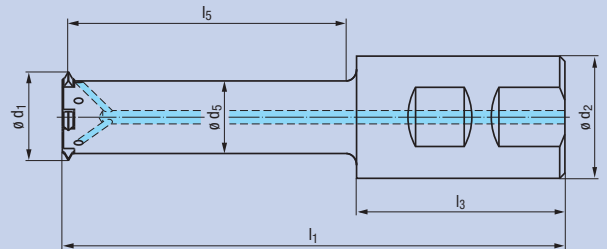

Gigant soft run

Gigant soft run sprinter

DIN 6535 HA



Z2 - Z3



Z5 - Z8



$\varnothing D_{min.}$ mm	l_1	l_3	l_5	$\varnothing d_1$	$\varnothing d_2$ h6	$\varnothing d_5$	Z (Inserts)	Gigant soft run		Gigant soft run sprinter	
								Gr. 10-1KZN		Gr. 10-1KZN	
20	97	45	50	17	12	12	2	GZ34A010	●		
24	115	48	65	20,5	16	15,9	3	GZ34A000	●		
30	142	50	90	23,85	20	19	5			GZ34C000	●
36	153	56	95	30	25	25	7			GZ34C010	●
40	178	60	115	32,85	32	27,7	8			GZ34C020	●

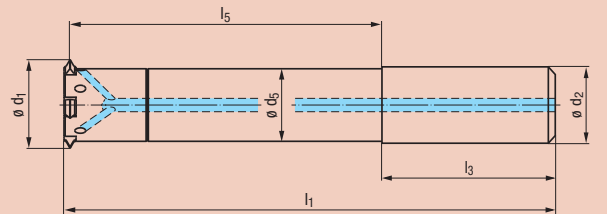

Mit variabler Länge auf Anfrage
With variable length upon request

Gigant modular

Nur einzeln einsetzbar
Can only be used individually

M



Z9



$\varnothing D_{min.}$ mm	l_6	$\varnothing d_1$	$\varnothing d_5$	G_1	SW (W/F)	Z (Inserts)	Gigant modular	
							Gr. 10-1KZN	
40	38	34,25	28,8	M16	22	9	GZ351000	●

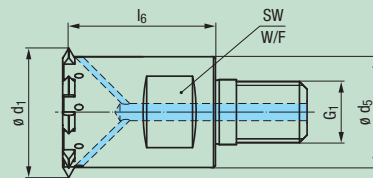

Gigant modular sprinter

Je nach Anwendung empfehlen wir, max. 3 Gigant modular sprinter miteinander zu kombinieren
Depending on the application, we recommend to combine up to a maximum of 3 Gigant modular sprinter

MF



Z6



new	$\varnothing D_{min.}$ mm	l_7	$\varnothing d_1$	$\varnothing d_5$	G_1	SW (W/F)	Z (Inserts)	Gigant modular Sprinter	
								Gr. 10-1KZN	
	32	24	27	22,15	M8 x 1	19	6	GZ353000	●

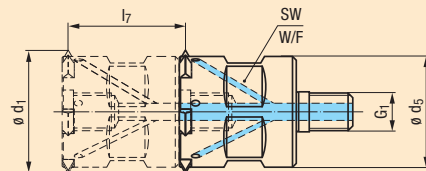

Die Innensechskant-Schraube zum stirnseitigen Verschließen der Kühlmittel-Bohrung ist im Lieferumfang enthalten
The hexagon socket screw to close the coolant hole on the face side is included with the delivery

Das Maß l_7 muss ein Vielfaches der Steigung P des herzustellenden Gewindes sein
The measurement l_7 must be a multiple of the pitch P of the thread to be produced

Fräsringe zum Entfernen des unvollständigen Ganges siehe Seite 442
Milling rings for removal of the incomplete thread, see page 442

Aufnahmen und Verlängerungen für Gigant modular und Gigant modular sprinter siehe Seite 444 - 445
Holders and extensions for Gigant modular and Gigant modular sprinter, see pages 444 - 445

10

2-Zahnwendeplatten für Steigungsbereich bis 3 mm (8 Gg/1")
 2-tooth indexable inserts for a pitch range up to 3 mm (8 tpi)

	HM RH + LH	
	Beschichtung · Coating	
Einsatzgebiete – Material Range of application – material ▶ 328		TIN TIALN-T4
P mm P Gg/1" (tpi) b h		P 1.1-5.1 M 1.1-4.1 K 1.1-4.2 N 1.1-4.4 S 1.1-3
		HM-WP-Z2 Gr. 10 TIN HM-WP-Z2 Gr. 10 TIALN-T4

<h2>M, MF, UN</h2> DIN 13, ANSI B1.1							
1 - 2,5	24 - 10	5	7	GF643005.9512	●	GF643007.9512	●
1,5 - 3	16 - 8	5	7	GF643005.9514	●	GF643007.9514	●

<h2>M, MF</h2> DIN 13						new	
1,5	5	7			GF641007.9514		●
2	5	7			GF641007.9516		●

<h2>G (BSP), BSW, BSF, W</h2> DIN EN ISO 228, BS 84							
(1,814)	14 (9 - 28)	5	7	GF643005.9548	●	GF643007.9548	●

<h2>Tr</h2> DIN 103						new		
1,5	5	7	$\varnothing D_{min.} = d_1 + 11$				GF643007.9597	●
2	5	7	$\varnothing D_{min.} = d_1 + 14$				GF643007.9599	●

Andere Ausführungen auf Anfrage, z.B.
 Other designs upon request, e.g.



Zubehör
 Accessories

- Ersatzschraube M2,5 x 8,5; Torx T7
 Spare screw M2.5 x 8.5; Torx T7
 - Schraubendreher Torx T7
 Screw driver Torx T7
 - Drehmoment-Schraubendreher Torx T7
 Torque screw driver Torx T7
 - Verschluss-Schraube M8x1 x 10; SW4
 Screw plug M8x1 x 10; SW4
- } **GZ349010**
} **GZ349020**
} **GZ349040**
} **GZ359310**

Product Finder

v_c / f_z

M

MF

UNC UN, UNS

UNF UNEF

G, Rp

NPT, NPTF Rc, W

BSW, BSF

Pg

EG (STI) SELF-LOCK

Tr

Zubehör Accessories

Tech. Info

BGF

ZBGF

GSF

GF

GF-KEG

ZGF

ZIRK-GF

Gigant

MoSys

Product Finder

v_c / f_z

M

MF

UNC
UN, UNS

UNF
UNEF

G Rp

NPT, NPTF
Rc, W

BSW, BSF

Pg

EG (STI)
SELF-LOCK

Tr

Zubehör
Accessories

Tech. Info

BGF

ZBGF

GSF

GF

GF-KEG

ZGF

ZIRK-GF

Gigant

MoSys



11

Für große Abmessungen ab Gewindedurchmesser 30 mm
For large thread sizes, from thread diameter 30 mm

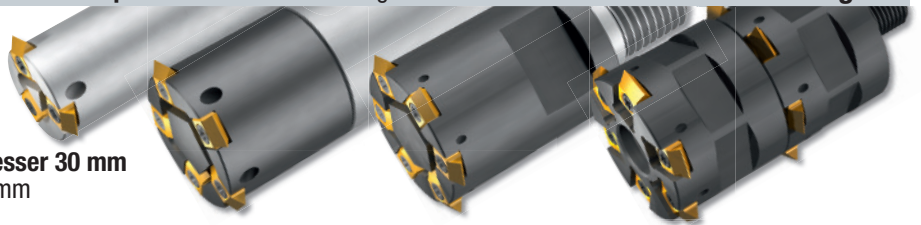

Gigant-ic

Gigant sprinter

DIN 1835 B		Z3		Z5 - Z8					
$\emptyset D_{min.}$ mm	l_1	l_3	l_5	$\emptyset d_1$	$\emptyset d_2$ h6	$\emptyset d_5$	Z (Inserts)	Gigant-ic Gr. 11-IKZN	Gigant sprinter Gr. 11-IKZN
30	122	60	60	23,85	32	19	3	GZ341121 ●	
30	138	56	80	23,85	25	19	3	GZ341021 ●	
30	142	60	80	23,85	32	19	3	GZ341001 ●	
30	152	60	90	23,85	32	19	3	GZ341101 ●	
34	153	60	90	28	32	23	5		GZ341211 ●
36	157	60	95	29,5	32	24,5	3	GZ341131 ●	
40	159	60	95	32,85	32	27,7	5		GZ341201 ●
40	124	60	60	34	32	28,8	6		GZ341221 ●
48	144	60	80	40,25	32	35	8		GZ341231 ●

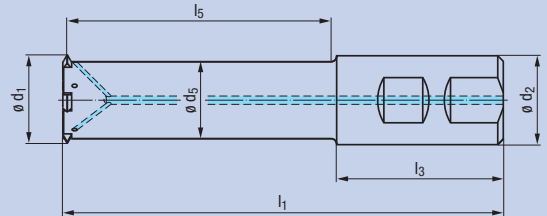

Gigant soft run

Gigant soft run sprinter

DIN 6535 HA		Z3		Z5					
$\emptyset D_{min.}$ mm	l_1	l_3	l_5	$\emptyset d_1$	$\emptyset d_2$ h6	$\emptyset d_5$	Z (Inserts)	Gigant soft run Gr. 11-IKZN	Gigant soft run sprinter Gr. 11-IKZN
30	142	50	90	23,85	20	19	3	GZ34A001 ●	
40	179	60	115	32,85	32	27,7	5		GZ34C001 ●

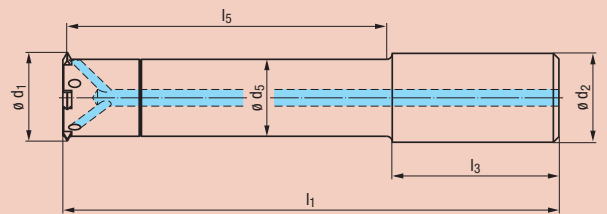

Mit variabler Länge auf Anfrage
With variable length upon request

Gigant modular

Nur einzeln einsetzbar
Can only be used individually

M		Z6					
$\emptyset D_{min.}$ mm	l_6	$\emptyset d_1$	$\emptyset d_5$	G_1	SW (W/F)	Z (Inserts)	Gigant modular Gr. 11-IKZN
42	38	34,25	28,8	M16	22	6	GZ351001 ●

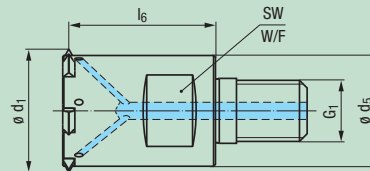

Gigant modular sprinter

Je nach Anwendung empfehlen wir, max. 3 Gigant modular sprinter
miteinander zu kombinieren
Depending on the application, we recommend to combine up to a maximum
of 3 Gigant modular sprinter

MF		Z6					
new $\emptyset D_{min.}$ mm	l_7	$\emptyset d_1$	$\emptyset d_5$	G_1	SW (W/F)	Z (Inserts)	Gigant modular sprinter Gr. 11-IKZN
42	24	34,25	29,15	M10 x 1	25	6	GZ353001 ●

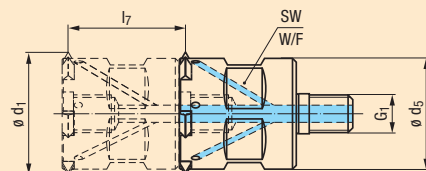

Das Maß l_7 muss ein Vielfaches der Steigung P des herzustellenden Gewindes sein
The measurement l_7 must be a multiple of the pitch P of the thread to be produced

Die Innensechskant-Schraube zum stirnseitigen Verschließen der Kühlmittel-Bohrung
ist im Lieferumfang enthalten
The hexagon socket screw to close the coolant hole on the face side
is included with the delivery

Fräsrings zum Entfernen des unvollständigen Ganges siehe Seite 442
Milling rings for removal of the incomplete thread, see page 442

Aufnahmen und Verlängerungen für Gigant modular und Gigant modular sprinter siehe Seite 444 - 445
Holders and extensions for Gigant modular and Gigant modular sprinter, see pages 444 - 445

11

4-Zahnwendeplatten für Steigungsbereich bis 4 mm (6 Gg/1") 4-tooth indexable inserts for a pitch range up to 4 mm (6 tpi)

	<div style="display: flex; gap: 10px;"> <div style="border: 1px solid black; padding: 2px;">HM</div> <div style="border: 1px solid black; padding: 2px;">RH + LH</div> </div>		
	Beschichtung · Coating		TIN
Einsatzgebiete – Material Range of application – material » 328		<div style="display: flex; justify-content: space-between; font-size: x-small;"> P 1.1-5.1 M 1.1-4.1 K 1.1-4.2 </div> <div style="display: flex; justify-content: space-between; font-size: x-small;"> N 1.1-4.4 S 1.1-3 </div>	
P mm	P Gg/1" (tpi)	b	h
		HM-WP-Z4 Gr. 11 TIN	HM-WP-Z4 Gr. 11 TIALN-T4

<h3>M, MF, UN</h3> <p>DIN 13, ANSI B1.1</p>							
1 - 2,5	24 - 10	6,35	9,52	GF643105.9512	●	GF643107.9512	●
1,5 - 2,5	16 - 10	6,35	9,52	GF643105.9514	●	GF643107.9514	●
2,5 - 4	10 - 6	6,35	9,52	GF643105.9517	●	GF643107.9517	●

<h3>M, MF</h3> <p>DIN 13</p>			new
2,5	6,35	9,52	GF641107.9517 ●
3	6,35	9,52	GF641107.9518 ●

<h3>G (BSP), BSW, BSF, W</h3> <p>DIN EN ISO 228, BS 84</p>							
(2,309)	11 (9 - 28)	6,35	9,52	GF643105.9550	●	GF643107.9550	●

<h3>NPT</h3> <p>ANSI/ASME B1.20.1</p>			new				
(2,209)	11 1/2	6,35	9,52	GF643107.9679	●		

<h3>Tr</h3> <p>DIN 103</p>			new				
3	6,35	9,52	$\varnothing D_{min.} = d_1 + 23$	GF643107.9601	●		
4	6,35	9,52	$\varnothing D_{min.} = d_1 + 32$	GF643107.9603	●		

Andere Ausführungen auf Anfrage, z.B.
Other designs upon request, e.g.



Einstechplatten in verschiedenen Ausführungen
Infeed inserts in various designs

Zubehör
Accessories

- Ersatzschraube M2,5 x 8,5; Torx T7
Spare screw M2.5 x 8.5; Torx T7 } GZ349011
- Schraubendreher Torx T7
Screw driver Torx T7 } GZ349021
- Drehmoment-Schraubendreher Torx T7
Torque screw driver Torx T7 } GZ349041
- Verschluss-Schraube M10x1 x 12; SW5
Screw plug M10x1 x 12; SW5 } GZ359311

Product Finder

v_c / f_z

M

MF

UNC
UN, UNS

UNF
UNEF

G, Rp

NPT NPTF
Rc, W

BSW, BSF

Pg

EG (STI)
SELF-LOCK

Tr

Zubehör
Accessories

Tech. Info

BGF

ZBGF

GSF

GF

GF-KEG

ZGF

ZIRK-GF

Gigant

MoSys

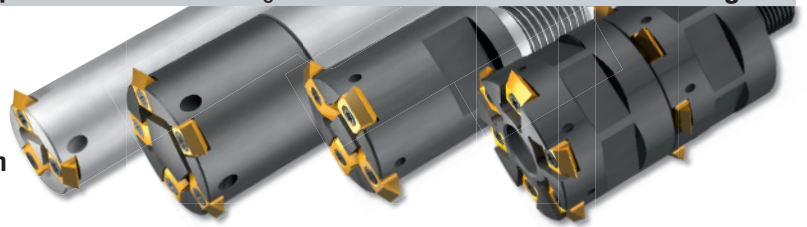

12

Für große Abmessungen ab Gewindedurchmesser 40 mm
For large thread sizes, from thread diameter 40 mm

Gigant-ic

Gigant sprinter

DIN 1835 B	Z3		Z5						
$\emptyset D_{min.}$ mm	l_1	l_3	l_5	$\emptyset d_1$	$\emptyset d_2$ h6	$\emptyset d_5$	Z (Inserts)	Gigant-ic Gr. 12-1KZN	Gigant sprinter Gr. 12-1KZN
40	153	56	95	32,85	25	24,5	3	GZ341032 ●	
40	158	60	95	32,85	32	24,5	3	GZ341012 ●	
40	178	60	115	32,85	32	24,5	3	GZ341112 ●	
48	172	60	110	40,25	32	31,9	5		GZ341202 ●

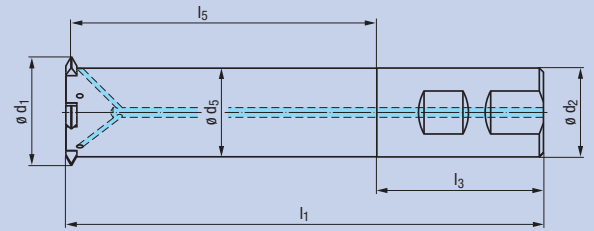

Gigant soft run

Gigant soft run sprinter

DIN 6535 HA	Z3		Z5						
$\emptyset D_{min.}$ mm	l_1	l_3	l_5	$\emptyset d_1$	$\emptyset d_2$ h6	$\emptyset d_5$	Z (Inserts)	Gigant soft run Gr. 12-1KZN	Gigant soft run sprinter Gr. 12-1KZN
40	173	56	115	32,85	25	24,5	3	GZ34A002 ●	
48	207	60	145	40,25	32	31,9	5		GZ34C002 ●

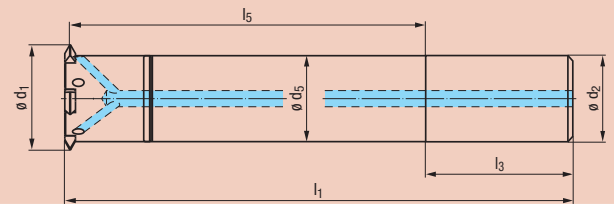

Mit variabler Länge auf Anfrage
With variable length upon request

Gigant modular

Nur einzeln einsetzbar
Can only be used individually

M	Z4						
$\emptyset D_{min.}$ mm	l_6	$\emptyset d_1$	$\emptyset d_5$	G_1	SW (W/F)	Z (Inserts)	Gigant modular Gr. 12-1KZN
46	38	37,5	28,8	M16	22	4	GZ351002 ●

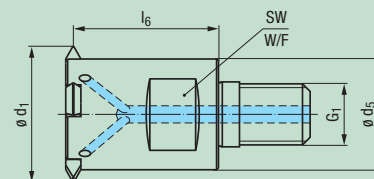

Gigant modular sprinter

Je nach Anwendung empfehlen wir, max. 3 Gigant modular sprinter miteinander zu kombinieren
Depending on the application, we recommend to combine up to a maximum of 3 Gigant modular sprinter

MF	Z6						
$\emptyset D_{min.}$ mm	l_7	$\emptyset d_1$	$\emptyset d_5$	G_1	SW (W/F)	Z (Inserts)	Gigant modular sprinter Gr. 12-1KZN
58	36	46	37,65	M12 x 1	32	6	GZ353002 ●

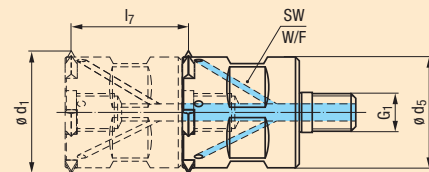

Das Maß l_7 muss ein Vielfaches der Steigung P des herzustellenden Gewindes sein
The measurement l_7 must be a multiple of the pitch P of the thread to be produced







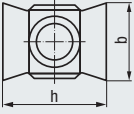

Die Innensechskant-Schraube zum stirnseitigen Verschließen der Kühlmittel-Bohrung ist im Lieferumfang enthalten
The hexagon socket screw to close the coolant hole on the face side is included with the delivery

Fräsringe zum Entfernen des unvollständigen Ganges siehe Seite 442
Milling rings for removal of the incomplete thread, see page 442

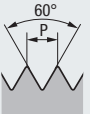
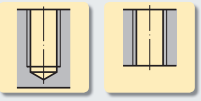
Aufnahmen und Verlängerungen für Gigant modular und Gigant modular sprinter siehe Seite 444 - 445
Holders and extensions for Gigant modular and Gigant modular sprinter, see pages 444 - 445

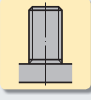
12

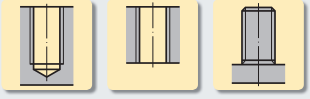
4-Zahnwendeplatten für Steigungsbereich bis 5,5 mm (4,5 Gg/1") 4-tooth indexable inserts for a pitch range up to 5.5 mm (4.5 tpi)

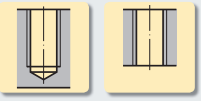
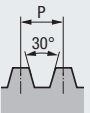
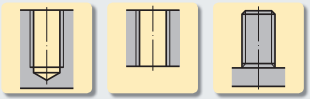



				HM	RH + LH		
Einsatzgebiete – Material Range of application – material				Beschichtung · Coating			
P mm	P Gg/1" (tpi)	b	h	HM-WP-Z4 Gr. 12 TIN		HM-WP-Z4 Gr. 12 TIALN-T4	
M, MF, UN DIN 13, ANSI B1.1  				P 1.1-5.1 M 1.1-4.1 K 1.1-4.2 N 1.1-4.4 S 1.1-3			
1,5 - 2,5	16 - 10	8,5	13,5	GF643205.9514	●	GF643207.9514	●
2,5 - 5,5	10 - 4,5	8,5	13,5	GF643205.9517	●	GF643207.9517	●
M, MF DIN 13  						new	
3,5		8,5	13,5			GF641207.9519	●
4		8,5	13,5			GF641207.9520	●
G (BSP), BSW, BSF, W DIN EN ISO 228, BS 84  							
(2,309)	11 (5 - 28)	8,5	13,5	GF643205.9550	●	GF643207.9550	●
NPT ANSI/ASME B1.20.1  						new	
(3,175)	8	8,5	13,5			GF643207.9680	●
Tr DIN 103  						new	
4		8,5	13,5			GF643207.9603	●
5		8,5	13,5			GF643207.9604	●
				$\varnothing D_{min.} = d_1 + 32$			
				$\varnothing D_{min.} = d_1 + 41$			

Andere Ausführungen auf Anfrage, z.B.
Other designs upon request, e.g.



 Einstechplatten in verschiedenen Ausführungen
Infeed inserts in various designs

Zubehör
Accessories

-  Ersatzschraube M3 x 11; Torx T9
Spare screw M3 x 11; Torx T9 } **GZ349012**
-  Schraubendreher Torx T9
Screw driver Torx T9 } **GZ349022**
-  Drehmoment-Schraubendreher Torx T9
Torque screw driver Torx T9 } **GZ349042**
-  Verschluss-Schraube M12x1 x 16; SW6
Screw plug M12x1 x 16; SW6 } **GZ359312**

Product Finder

v_c / f_z

M

MF

UNC
UN, UNS

UNF
UNEF

G, Rp

NPT NPTF
Rc, W

BSW, BSF

Pg

EG (STI)
SELF-LOCK

Tr

Zubehör
Accessories

Tech. Info

BGF

ZBGF

GSF

GF

GF-KEG

ZGF

ZIRK-GF

Gigant

MoSys



13

Für große Abmessungen ab Gewindedurchmesser 48 mm
For large thread sizes, from thread diameter 48 mm

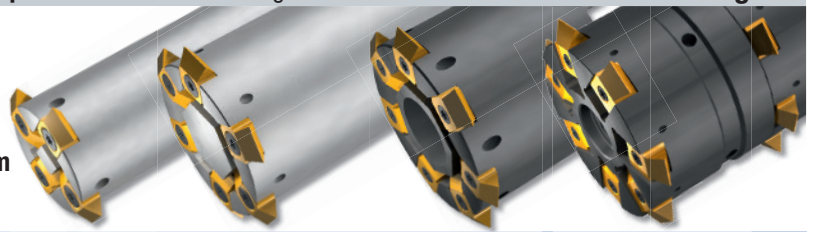

Gigant-ic

Gigant sprinter

DIN 1835 B			Z4					
$\emptyset D_{min.}$ mm	l_1	l_3	l_5	$\emptyset d_1$	$\emptyset d_2$ h6	$\emptyset d_5$	Z (Inserts)	Gigant-ic Gr. 13-IKZN
48	173	60	110	40,25	32	31	4	GZ341153 ●
48	208	60	145	40,25	32	31	4	GZ341143 ●

DIN 69871			Z4	Z6				
$\emptyset D_{min.}$ mm	l_1	l_5	$\emptyset d_1$	SK	$\emptyset d_5$	Z (Inserts)	Gigant-ic Gr. 13-IKZN	Gigant sprinter Gr. 13-IKZN
48	212	110	40,25	SK 40	31	4	GZ343003 ●	
48	245	110	40,25	SK 50	31	4	GZ344003 ●	
48	247	145	40,25	SK 40	31	4	GZ343103 ●	
48	280	145	40,25	SK 50	31	4	GZ344103 ●	
64	333	195	52,55	SK 50	43,75	6		GZ344203 ●

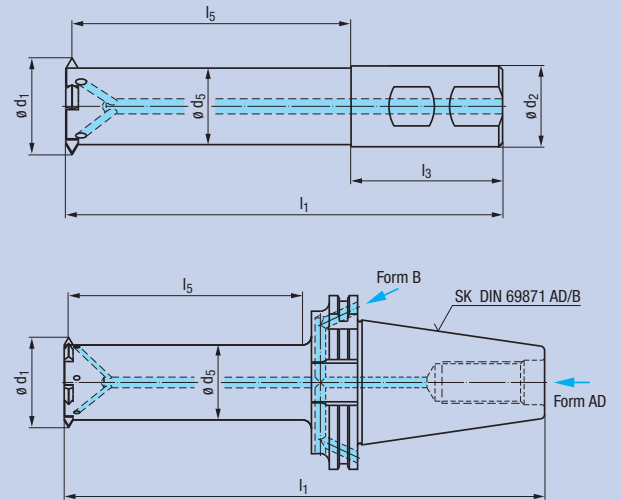

Gigant soft run

DIN 6535 HA			Z4					
$\emptyset D_{min.}$ mm	l_1	l_3	l_5	$\emptyset d_1$	$\emptyset d_2$ h6	$\emptyset d_5$	Z (Inserts)	Gigant soft run Gr. 13-IKZN
48	207	60	145	40,25	32	31	4	GZ34A003 ●

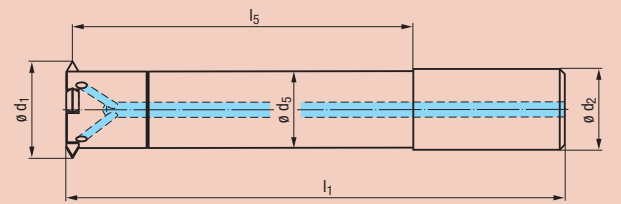

Mit variabler Länge auf Anfrage
With variable length upon request

Gigant modular

DIN 138			Z7				
$\emptyset D_{min.}$ mm	l_6	$\emptyset d_1$	$\emptyset d_5$	$\emptyset D_3$	Z (Inserts)	Gigant modular Gr. 13-IKZN	
66	47,5	57,5	48	27	7	GZ352003 ●	

Nur einzeln einsetzbar
Can only be used individually

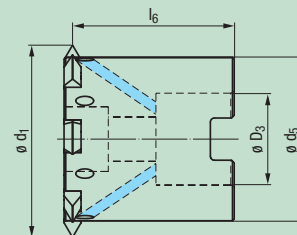

Gigant modular sprinter

MF			Z7				
new	$\emptyset D_{min.}$ mm	l_7	$\emptyset d_1$	$\emptyset d_5$	G ₁	Z (Inserts)	Gigant modular sprinter Gr. 13-IKZN
	66	48	57,5	48	M18 x 1,5	7	GZ353003 ●

Je nach Anwendung empfehlen wir, max. 3 Gigant modular sprinter miteinander zu kombinieren
Depending on the application, we recommend to combine up to a maximum of 3 Gigant modular sprinter

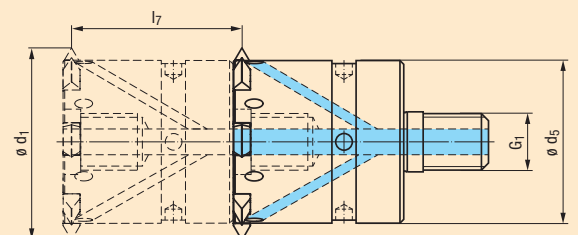

Die Innensechskant-Schraube zum stirnseitigen Verschließen der Kühlmittel-Bohrung ist im Lieferumfang enthalten
The hexagon socket screw to close the coolant hole on the face side is included with the delivery



Das Maß l_7 muss ein Vielfaches der Steigung P des herzustellenden Gewindes sein
The measurement l_7 must be a multiple of the pitch P of the thread to be produced

Fräsringe zum Entfernen des unvollständigen Ganges siehe Seite 442
Milling rings for removal of the incomplete thread, see page 442

Aufnahmen und Verlängerungen für Gigant modular und Gigant modular sprinter siehe Seite 444 - 445
Holders and extensions for Gigant modular and Gigant modular sprinter, see pages 444 - 445

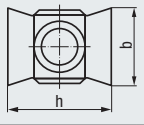

13

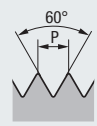
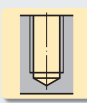
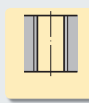

4-Zahnwendeplatten für Steigungsbereich bis 6 mm (4 Gg/1")
 4-tooth indexable inserts for a pitch range up to 6 mm (4 tpi)

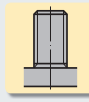
	HM RH + LH		
	Beschichtung · Coating	TIN	TIALN-T4
Einsatzgebiete – Material Range of application – material ▶ 328	P 1.1-5.1 M 1.1-4.1 K 1.1-4.2 N 1.1-4.4 S 1.1-3		
P mm P Gg/1" (tpi) b h	HM-WP-Z4 Gr. 13 TIN	HM-WP-Z4 Gr. 13 TIALN-T4	

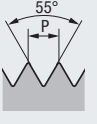
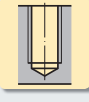
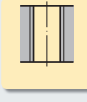
M, MF, UN DIN 13, ANSI B1.1			
1,5 - 3 16 - 9 9,5 15,5 3 - 6 9 - 4 9,5 15,5	GF643305.9514 ● GF643307.9514 ● GF643305.9518 ● GF643307.9518 ●		

M, MF DIN 13			new
4,5 9,5 15,5 5 9,5 15,5			GF641307.9521 ● GF641307.9522 ●

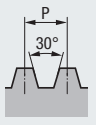
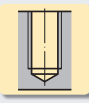
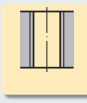
G (BSP), BSW, BSF, W DIN EN ISO 228, BS 84				
(2,309) 11 (4.5 - 12) 9,5 15,5				GF643305.9550 ● GF643307.9550 ●

Tr DIN 103					new
5 9,5 15,5 $\varnothing D_{min.} = d_1 + 43$ 6 9,5 15,5 $\varnothing D_{min.} = d_1 + 53$					GF643307.9604 ● GF643307.9605 ●

Andere Ausführungen auf Anfrage, z.B.
 Other designs upon request, e.g.



Zubehör
 Accessories

- 
 Ersatzschraube M4 x 13; Torx T15
 Spare screw M4 x 13; Torx T15 } **GZ349013**
- 
 Schraubendreher Torx T15
 Screw driver Torx T15 } **GZ349023**
- 
 Drehmoment-Schraubendreher Torx T15
 Torque screw driver Torx T15 } **GZ349043**
- 
 Hakenschlüssel mit Zapfen
 nach DIN 1810-B 45-50 mm
 Hook wrench type B with pin
 acc. to DIN 1810-B 45-50 mm } **GZ349053**
- 
 Verschluss-Schraube M18x1,5 x 20; SW10
 Screw plug M18x1.5 x 20; SW10 } **GZ359313**

Product Finder

v_c / f_z

M

MF

UNC
UN, UNS

UNF
UNEF

G, Rp

NPT, NPTF
Rc, W

BSW, BSF

Pg

EG (STI)
SELF-LOCK

Tr

Zubehör
Accessories

Tech. Info

BGF

ZBGF

GSF

GF

GF-KEG

ZGF

ZIRK-GF

Gigant

MoSys



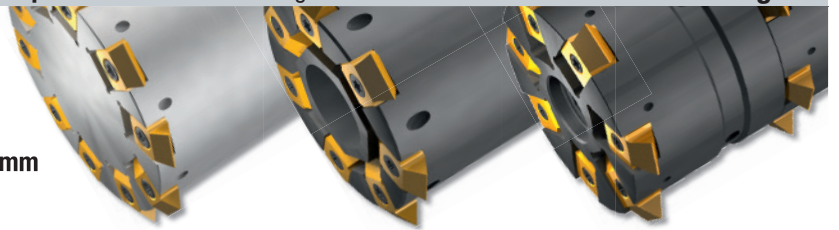

14

Für große Abmessungen ab Gewindedurchmesser 64 mm
For large thread sizes, from thread diameter 64 mm

Gigant-ic

Gigant sprinter

DIN 69871 AD/B		Z4 - Z7		Z10		Gigant-ic		Gigant sprinter	
				Gr. 14-1KZN		Gr. 14-1KZN			
$\varnothing D_{min.}$ mm	l_1	l_5	$\varnothing d_1$	SK	$\varnothing d_5$	Z (Inserts)			
64	253	150	52,55	SK 40	41	4	GZ343014	●	
64	286	150	52,55	SK 50	41	4	GZ344014	●	
64	298	195	52,55	SK 40	41	4	GZ343114	●	
64	331	195	52,55	SK 50	41	4	GZ344114	●	
80	308	170	66,55	SK 50	55	7	GZ344024	●	
80	398	260	66,55	SK 50	55	7	GZ344124	●	
115	489	360	92	SK 50	80	10			GZ344204 ●

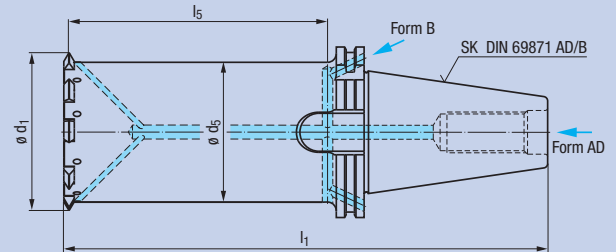

Gigant modular

DIN 138		Z7		Gigant modular		
$\varnothing D_{min.}$ mm	l_6	$\varnothing d_1$	$\varnothing d_5$	$\varnothing D_3$	Z (Inserts)	Gr. 14-1KZN
80	47	71,5	60	27	7	GZ352004 ●

Nur einzeln einsetzbar
Can only be used individually

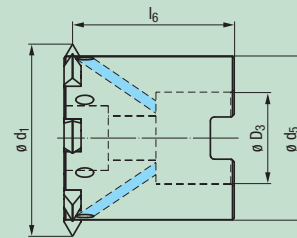

Gigant modular sprinter

MF		Z7		Gigant modular sprinter		
$\varnothing D_{min.}$ mm	l_7	$\varnothing d_1$	$\varnothing d_5$	G_1	Z (Inserts)	Gr. 14-1KZN
80	60	71,5	60	M24 x 1,5	7	GZ353004 ●

Je nach Anwendung empfehlen wir, max. 3 Gigant modular sprinter miteinander zu kombinieren
Depending on the application, we recommend to combine up to a maximum of 3 Gigant modular sprinter

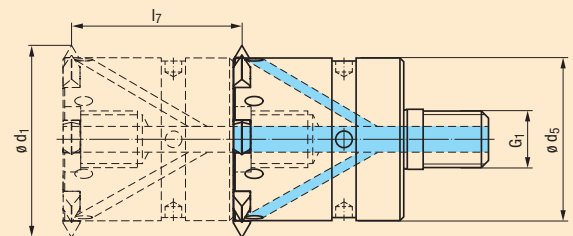

Die Innensechskant-Schraube zum stirnseitigen Verschließen der Kühlmittel-Bohrung ist im Lieferumfang enthalten
The hexagon socket screw to close the coolant hole on the face side is included with the delivery

Das Maß l_7 muss ein Vielfaches der Steigung P des herzustellenden Gewindes sein
The measurement l_7 must be a multiple of the pitch P of the thread to be produced

Fräsringe zum Entfernen des unvollständigen Ganges siehe Seite 442
Milling rings for removal of the incomplete thread, see page 442

Aufnahmen und Verlängerungen für Gigant modular und Gigant modular sprinter siehe Seite 444 - 445
Holders and extensions for Gigant modular and Gigant modular sprinter, see pages 444 - 445

14

4-Zahnwendeplatten für Steigungsbereich bis 8 mm (3,5 Gg/1")
 4-tooth indexable inserts for a pitch range up to 8 mm (3.5 tpi)

	<div style="display: flex; gap: 10px;"> <div style="border: 1px solid black; padding: 2px;">HM</div> <div style="border: 1px solid black; padding: 2px;">RH + LH</div> </div>		
	Beschichtung · Coating		TIN
Einsatzgebiete – Material Range of application – material ▶ 328		<div style="display: flex; justify-content: space-between; font-size: small;"> P 1.1-5.1 M 1.1-4.1 K 1.1-4.2 </div> <div style="display: flex; justify-content: space-between; font-size: small;"> N 1.1-4.4 S 1.1-3 </div>	
P mm	P Gg/1" (tpi)	b	h
		HM-WP-Z4 Gr. 14 TIN	HM-WP-Z4 Gr. 14 TIALN-T4

<h2>M, MF, UN</h2> <p>DIN 13, ANSI B1.1</p>					
1,5 - 3 3 - 6	16 - 9 9 - 4	12,5 12,5	19 19	GF643405.9514 GF643405.9518	● ●
				GF643407.9514 GF643407.9518	● ●

<h2>M, MF</h2> <p>DIN 13</p>				new	
5,5 6		12,5 12,5	19 19		● ●
				GF641407.9709 GF641407.9523	● ●

<h2>G (BSP), BSW, BSF, W</h2> <p>DIN EN ISO 228, BS 84</p>					
(2,309)	11 (3.5 - 12)	12,5	19	GF643405.9550	●
				GF643407.9550	●

<h2>Tr</h2> <p>DIN 103</p>				new	
6 8		12,5 12,5	19 19	$\varnothing D_{min.} = d_1 + 61$ $\varnothing D_{min.} = d_1 + 84$	● ●
				GF643407.9605 GF643407.9736	● ●

Andere Ausführungen auf Anfrage, z.B.
 Other designs upon request, e.g.



Zubehör
 Accessories

- Ersatzschraube M5 x 15; Torx T20
 Spare screw M5 x 15; Torx T20 } GZ349014
- Schraubendreher Torx T20
 Screw driver Torx T20 } GZ349024
- Drehmoment-Schraubendreher Torx T20
 Torque screw driver Torx T20 } GZ349044
- Hakenschlüssel mit Zapfen
 nach DIN 1810-B 58-62 mm
 Hook wrench type B with pin
 acc. to DIN 1810-B 58-62 mm } GZ349054
- Verschluss-Schraube M24x1,5 x 25; SW12
 Screw plug M24x1.5 x 25; SW12 } GZ359314

Product Finder

v_c / f_z

M

MF

UNC
UN, UNS

UNF
UNEF

G, Rp

NPT, NPTF
Rc, W

BSW, BSF

Pg

EG (STI)
SELF-LOCK

Tr

Zubehör
Accessories

Tech. Info

BGF

ZBGF

GSF

GF

GF-KEG

ZGF

ZIRK-GF

Gigant

MoSys

Product Finder

v_c / f_z

15

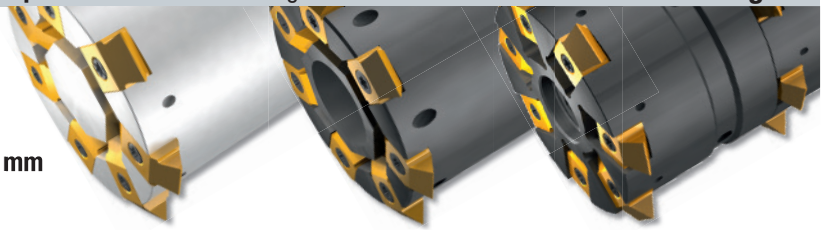

M

Für große Abmessungen ab Gewindedurchmesser 115 mm
For large thread sizes, from thread diameter 115 mm

MF

UNC
UN, UNS

Gigant-ic

DIN 69871



Z7



$\varnothing D_{min.}$ mm	l_1	l_5	$\varnothing d_1$	SK	$\varnothing d_5$	Z (Inserts)	Gigant-ic Gr. 15-IKZN
115	341	204	92	SK 50	76	7	GZ344035 ●
115	497	360	92	SK 50	76	7	GZ344045 ●

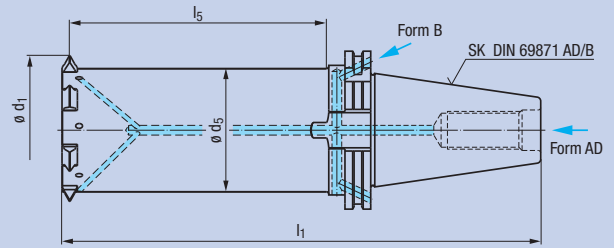

NPT, NPTF
Rc, W

BSW, BSF

Pg

EG (STI)
SELF-LOCK

Gigant modular

DIN 138



Z7



$\varnothing D_{min.}$ mm	l_6	$\varnothing d_1$	$\varnothing d_5$	$\varnothing D_3$	Z (Inserts)	Gigant modular Gr. 15-IKZN
115	55	94	78	32	7	GZ352005 ●

Nur einzeln einsetzbar
Can only be used individually

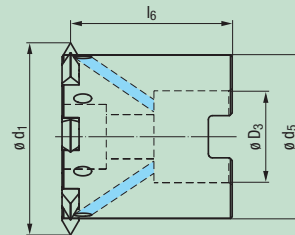

Zubehör
Accessories

Tech. Info

BGF

ZBGF

GSF

GF

GF-KEG

ZGF

ZIRK-GF

Gigant

MoSys

Gigant modular sprinter

MF



Z7



new	$\varnothing D_{min.}$ mm	l_7	$\varnothing d_1$	$\varnothing d_5$	G_1	Z (Inserts)	Gigant modular sprinter Gr. 15-IKZN
	115	60	94	78	M24 x 1,5	7	GZ353005 ●

Je nach Anwendung empfehlen wir, max. 3 Gigant modular sprinter
miteinander zu kombinieren
Depending on the application, we recommend to combine up to a maximum
of 3 Gigant modular sprinter

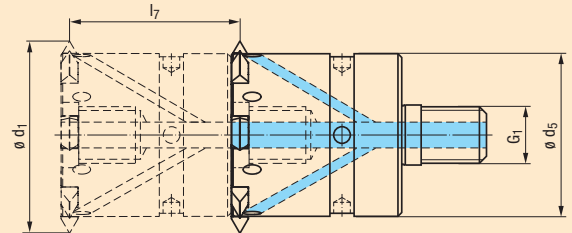

Die Innensechskant-Schraube zum stirnseitigen Verschließen der Kühlmittel-Bohrung
ist im Lieferumfang enthalten
The hexagon socket screw to close the coolant hole on the face side
is included with the delivery

Das Maß l_7 muss ein Vielfaches der Steigung P des herzustellenden Gewindes sein
The measurement l_7 must be a multiple of the pitch P of the thread to be produced



Aufnahmen und Verlängerungen für Gigant modular und Gigant modular sprinter siehe Seite 444 - 445
Holders and extensions for Gigant modular and Gigant modular sprinter, see pages 444 - 445

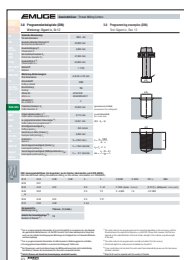



Programmierbeispiel für Gewindefräser
Typ Gigant siehe Seite 470

Programming example for thread miller
cutters type Gigant, see page 470

15

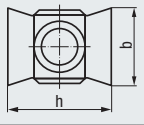
4-Zahnwendeplatten für Steigungsbereich bis 12 mm (4 Gg/1") 4-tooth indexable inserts for a pitch range up to 12 mm (4 tpi)

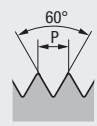
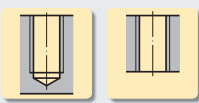
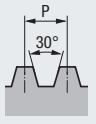
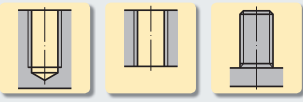
				HM RH + LH					
Einsatzgebiete – Material Range of application – material				Beschichtung · Coating		TIN		TIALN-T4	
P mm P Gg/1" (tpi) b h				P 1.1-5.1 M 1.1-4.1 K 1.1-4.2 N 1.1-4.4 S 1.1-3		HM-WP-Z4 Gr. 15 TIN		HM-WP-Z4 Gr. 15 TIALN-T4	
<h1>M, MF, UN</h1> DIN 13, ANSI B1.1									
1,5 - 6 16 - 4 14,3 28,58 6 - 8 4 14,3 28,58				GF643505.9514 ● GF643507.9514 ● GF643505.9523 ● GF643507.9523 ●					
<h1>Tr</h1> DIN 103								new	
10 14,3 28,58 $\varnothing D_{min.} = d_1 + 101$ 12 14,3 28,58 $\varnothing D_{min.} = d_1 + 122$						GF643507.9748 ● GF643507.9749 ●			

Andere Ausführungen auf Anfrage, z.B.
Other designs upon request, e.g.



Zubehör
Accessories

- 
 Ersatzschraube M5 x 18; Torx T20
Spare screw M5 x 18; Torx T20
- 
 Schraubendreher Torx T20
Screw driver Torx T20
- 
 Drehmoment-Schraubendreher Torx T20
Torque screw driver Torx T20
- 
 Hakenschlüssel mit Zapfen
nach DIN 1810-B 68-75 mm
Hook wrench type B with pin
acc. to DIN 1810-B 68-75 mm
- 
 Verschluss-Schraube M24x1,5 x 25; SW12
Screw plug M24x1.5 x 25; SW12

Product Finder

v_c / f_z

M

MF

UNC
UN, UNS

UNF
UNEF

G, Rp

NPT, NPTF
Rc, W

BSW, BSF

Pg

EG (STI)
SELF-LOCK

Tr

Zubehör
Accessories

Tech. Info

BGF

ZBGF

GSF

GF

GF-KEG

ZGF

ZIRK-GF

Gigant

MoSys



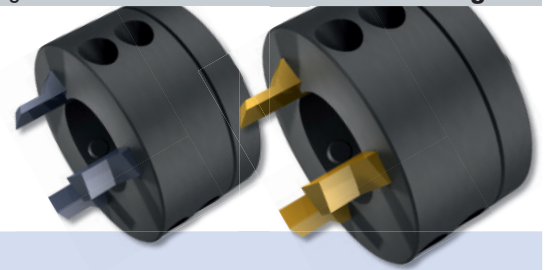

Product Finder

v_c / f_z

M

MF

UNC
UN, UNS

UNF
UNEF

G, Rp

NPT, NPTF
Rc, W

BSW, BSF

Pg

EG (STI)
SELF-LOCK

Tr

Zubehör
Accessories

Tech. Info

BGF

ZBGF

GSF

GF

GF-KEG

ZGF

ZIRK-GF

Gigant

MoSys



10-14

Fräsringe zum Entfernen des unvollständigen Ganges
Milling rings for removal of the incomplete thread

Gigant-ic



new	Größe Size	$\varnothing d_1$	$\varnothing D_5 / d_5$	l_6	l_7	$\varnothing d_6$	Z (Inserts)		
	10	20,5	15,9	18	23	33	3	GZ80FOC4.010040	●
	11	23,85	19	18	22	37	3	GZ80GOC4.011040	●
	12	32,85	24,5	22	24	47	3	GZ80HOC4.012060	●
	13	40,25	31	22	24	55	4	GZ80IOC4.013060	●
	14	52,55	41	22	23	65	4	GZ80JOC4.014060	●

Das Maß „x P“ muss ein Vielfaches der Steigung P des herzustellenden Gewindes sein
The measurement "x P" must be a multiple of the pitch P of the thread to be produced

Die Nuttiefe l_5 des Zirkular-Gewindefräskörpers verringert sich um das Maß l_7
The usable depth l_5 of the circular thread milling body is reduced by dimension l_7

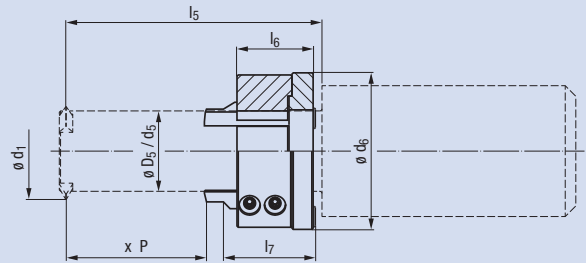

1-Zahn-Fräsplatten für Fräsringe

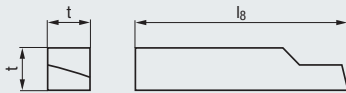
1-tooth milling inserts for milling rings

HM

RH + LH

new



new



Beschichtung · Coating

TIN

TIALN-T4

Einsatzgebiete – Material
Range of application – material [» 328](#)

P 1.1-5.1 M 1.1-4.1 K 1.1-4.2
N 1.1-4.4 S 1.1-3

HM-FP-Z1

HM-FP-Z1

TIN

TIALN-T4

Größe Size	l_8	t		
10	20	4	GF663005	● GF663007 ●
11	20	4	GF663105	● GF663107 ●
12	25	6	GF663205	● GF663207 ●
13	25	6	GF663305	● GF663307 ●
14	25	6	GF663405	● GF663407 ●



Product
Finder

v_c / f_z

M

MF

UNC
UN, UNS

UNF
UNEF

G, Rp

NPT, NPTF
Rc, W

BSW, BSF

Pg

EG (STI)
SELF-LOCK

Tr

Zubehör
Accessories

Tech. Info

BGF

ZBGF

GSF

GF

GF-KEG

ZGF

ZIRK-GF

Gigant

MoSys



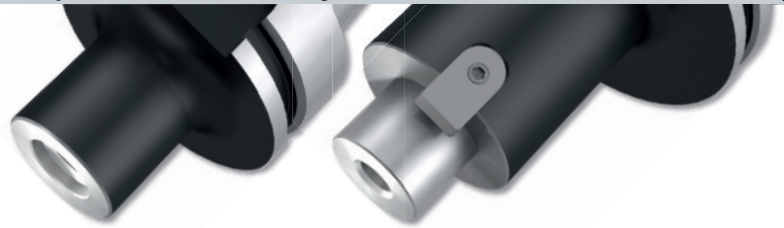

Product Finder

v_c / f_z

M

MF

UNC
UN, UNS

UNF
UNEF

G, Rp

NPT, NPTF
Rc, W

BSW, BSF

Pg

EG (STI)
SELF-LOCK

Tr

Zubehör
Accessories

Tech. Info

BGF

ZBGF

GSF

GF

GF-KEG

ZGF

ZIRK-GF

Gigant

MoSys



10-15

Aufnahmen für Gigant modular Holders for Gigant modular

HSK-A

DIN 69893-1



Größe Size	G ₁	∅ d ₅	l ₅	l _A	HSK	
10-12	M16	29	29	59	HSK-A63	GZ5391A4.116059 ●

DIN 138



Größe Size	∅ D ₃	∅ d ₅	l ₅	l ₃	l _A	HSK	
13	27	48	131	21	160	HSK-A63	GZ5391B4.270160 ●
14	27	60	131	21	160	HSK-A63	GZ5391B5.270160 ●
15	32	78	171	24	200	HSK-A63	GZ5391B4.320200 ●

SK (ISO)

DIN 69871



Größe Size	G ₁	∅ d ₅	l ₅	l _A	SK	
10-12	M16	29	11	36	SK 40	GZ5243A4.116036 ●
10-12	M16	29	11	36	SK 50	GZ5263A4.116036 ●

DIN 138



Größe Size	∅ D ₃	∅ d ₅	l ₅	l ₃	l _A	SK	
13	27	48	132	21	160	SK 50	GZ5263B4.270160 ●
14	27	60	132	21	160	SK 50	GZ5263B5.270160 ●
15	32	78	174	24	200	SK 50	GZ5263B4.320200 ●

HSS-Verlängerungen für Gigant modular HSS extensions for Gigant modular

∅32

DIN 1835 A



Größe Size	G ₁	∅ d ₅	l ₅	l ₁	∅ d ₂ h6	
10-12	M16	29,4	108	200	32	GZ5521A4.320108 ●

Zwischenadapter für Gigant modular Intermediate adapters for Gigant modular

M16



Größe Size	G ₁	∅ d ₅	l _A	SW (W/F)	G ₂	
10-12	M16	29	40	22	M16	GZ56E1A4.116040 ●
10-12	M16	29	90	22	M16	GZ56E1A4.116090 ●

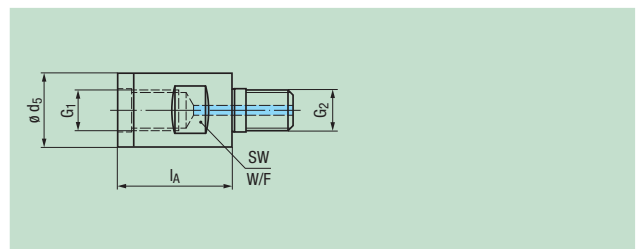
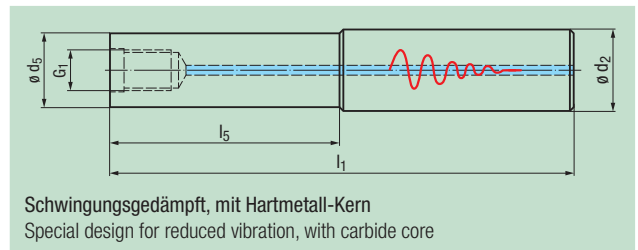
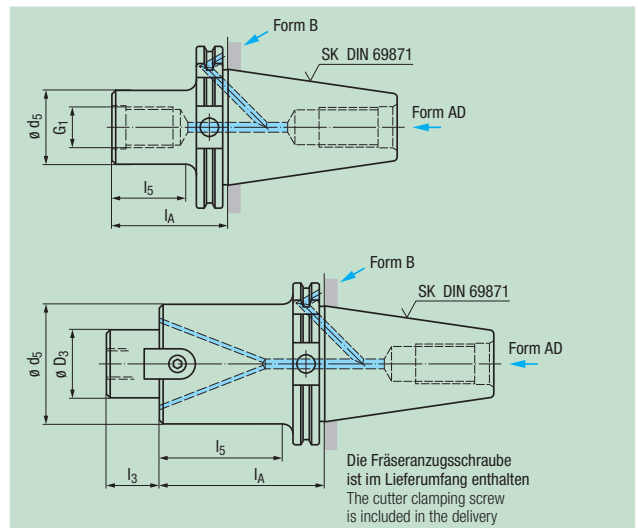
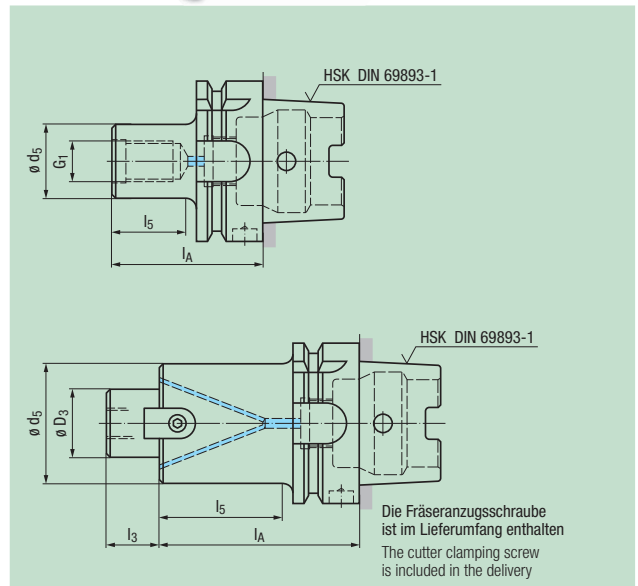

10-15

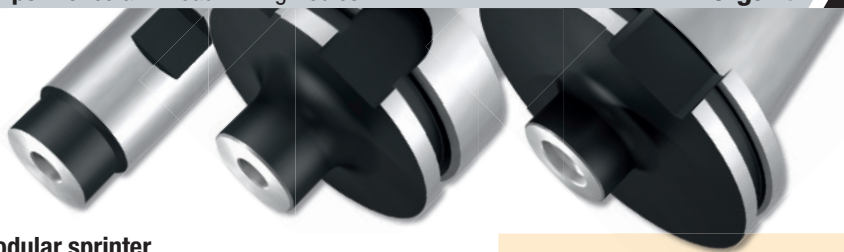

Aufnahmen für Gigant modular sprinter Holders for Gigant modular sprinter

HSK-A

DIN 69893-1



MF



Größe Size	G ₁	∅ d ₅	l ₅	l _A	HSK		
10	M 8 x 1	22,15	10	45	HSK-A63	GZ7391AA.251010	●
11	M10 x 1	29,15	10	45	HSK-A63	GZ7391AB.276010	●
12	M12 x 1	37,65	12	45	HSK-A63	GZ7391AC.301012	●
13	M18 x 1,5	48	32	60	HSK-A63	GZ7391AD.390032	●
14	M24 x 1,5	60	40	80	HSK-A100	GZ73A1AE.452040	●
15	M24 x 1,5	78	45	76	HSK-A100	GZ73A1AF.452045	●

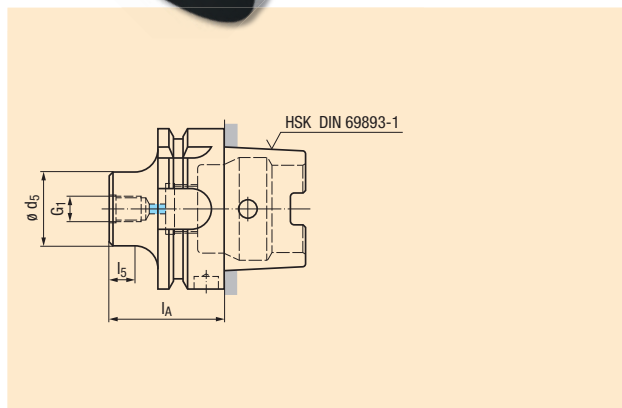

SK (ISO)

DIN 69871



MF



Größe Size	G ₁	∅ d ₅	l ₅	l _A	SK		
10	M 8 x 1	22,15	10	35	SK 40	GZ7243AA.251010	●
11	M10 x 1	29,15	10	35	SK 40	GZ7243AB.276010	●
12	M12 x 1	37,65	12	35	SK 40	GZ7243AC.301012	●
13	M18 x 1,5	48	15	37	SK 40	GZ7243AD.390015	●
14	M24 x 1,5	60	15	40	SK 50	GZ7263AE.452015	●
15	M24 x 1,5	78	20	45	SK 50	GZ7263AF.452020	●

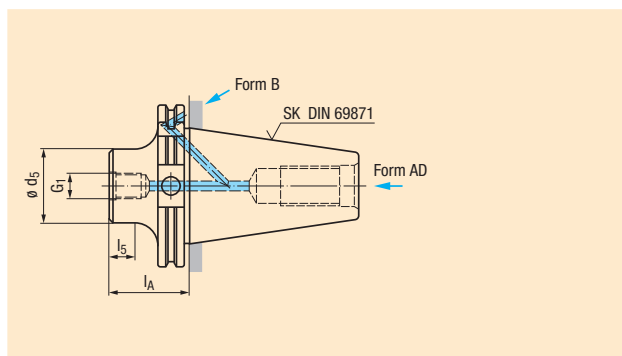

∅25-∅32

DIN 1835 B



MF



Größe Size	G ₁	∅ d ₅	l ₅	l ₁	∅ d ₂ h ₆		
10	M 8 x 1	22,15	10	68	25	GZ75D1AA.251010	●
11	M10 x 1	29,15	10	72	32	GZ7521AB.276010	●
12	M12 x 1	37,65	12	77	32	GZ7521AC.301012	●

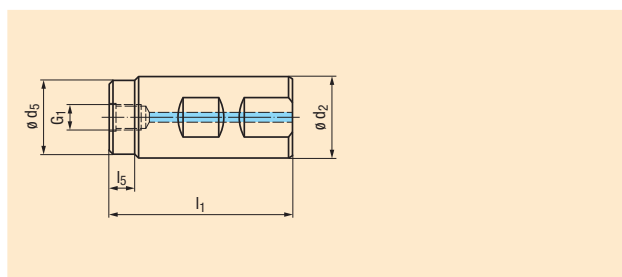

Product
Finder

v_c / f_z

M

MF

UNC
UN, UNS

UNF
UNEF

G, Rp

NPT, NPTF
Rc, W

BSW, BSF

Pg

EG (STI)
SELF-LOCK

Tr

Zubehör
Accessories

Tech. Info

BGF

ZBGF

GSF

GF

GF-KEG

ZGF

ZIRK-GF

Gigant

MoSys



- Product Finder
- v_c / f_z
- M
- MF
- UNC
UN, UNS
- UNF
UNEF
- G, Rp
- NPT, NPTF
Rc, W
- BSW, BSF
- Pg
- EG (STI)
SELF-LOCK
- Tr
- Zubehör
Accessories
- Tech. Info
- BGF
- ZBGF
- GSF
- GF
- GF-KEG
- ZGF
- ZIRK-GF
- Gigant
- MoSys**

„MoSys“ gestattet vielseitige Plan- und Stufensenkoperationen!

In einer Aufspannung erzielen Sie folgende Vorteile:

- Geringe Anzahl an Werkzeugen
- Wenig Lagerplätze und Lagerkosten
- Kurze Bearbeitungszeiten

„MoSys“ erfüllt folgende Voraussetzungen:

- Einfache Montage
- Hohe Steifigkeit
- Hohe Maßgenauigkeit
- Modular aufgebaut und einsetzbar

„MoSys“ makes a large number of counterbore and stepped bore operations possible!

With just one clamping operation, you enjoy a number of advantages:

- Smaller tool quantities
- Fewer magazine places and reduced stocking costs
- Shorter machining times

„MoSys“ answers to the following requirements:

- Easy assembly
- High degree of rigidity
- High dimensional precision
- Modular construction for universal application

MoSys mit Vollhartmetall-Kopf

MoSys with solid carbide head

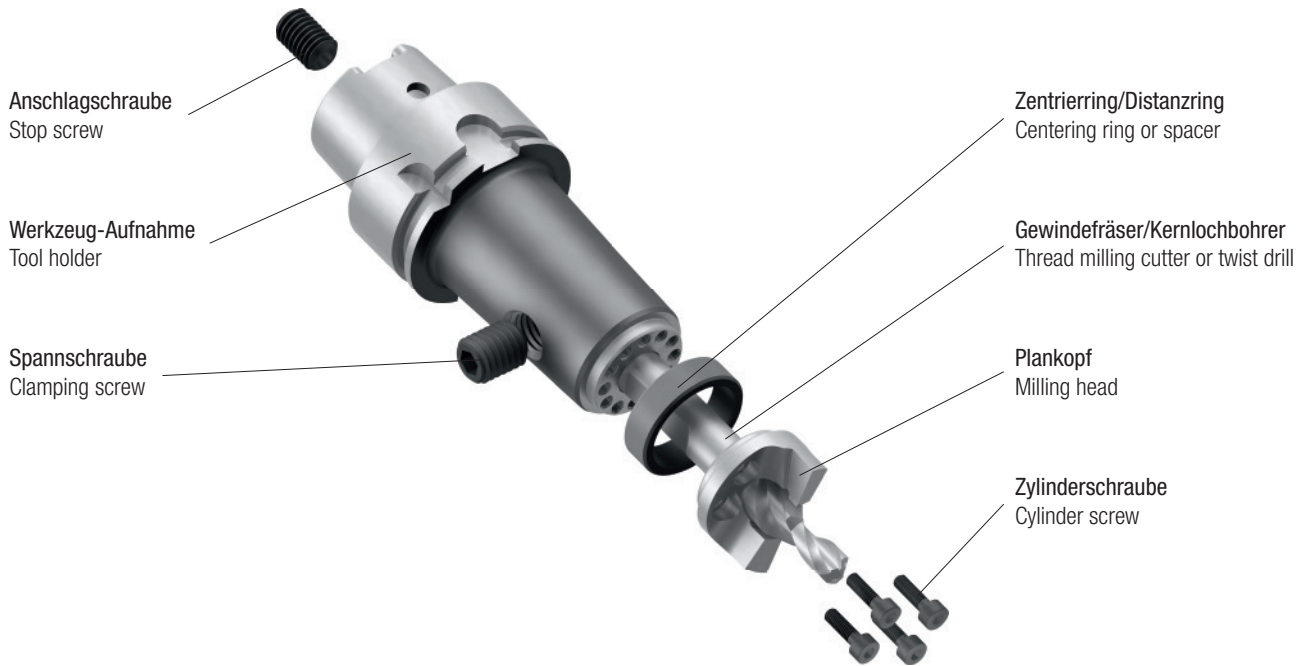

MoSys mit Wendeschneidplatten

MoSys with indexable inserts

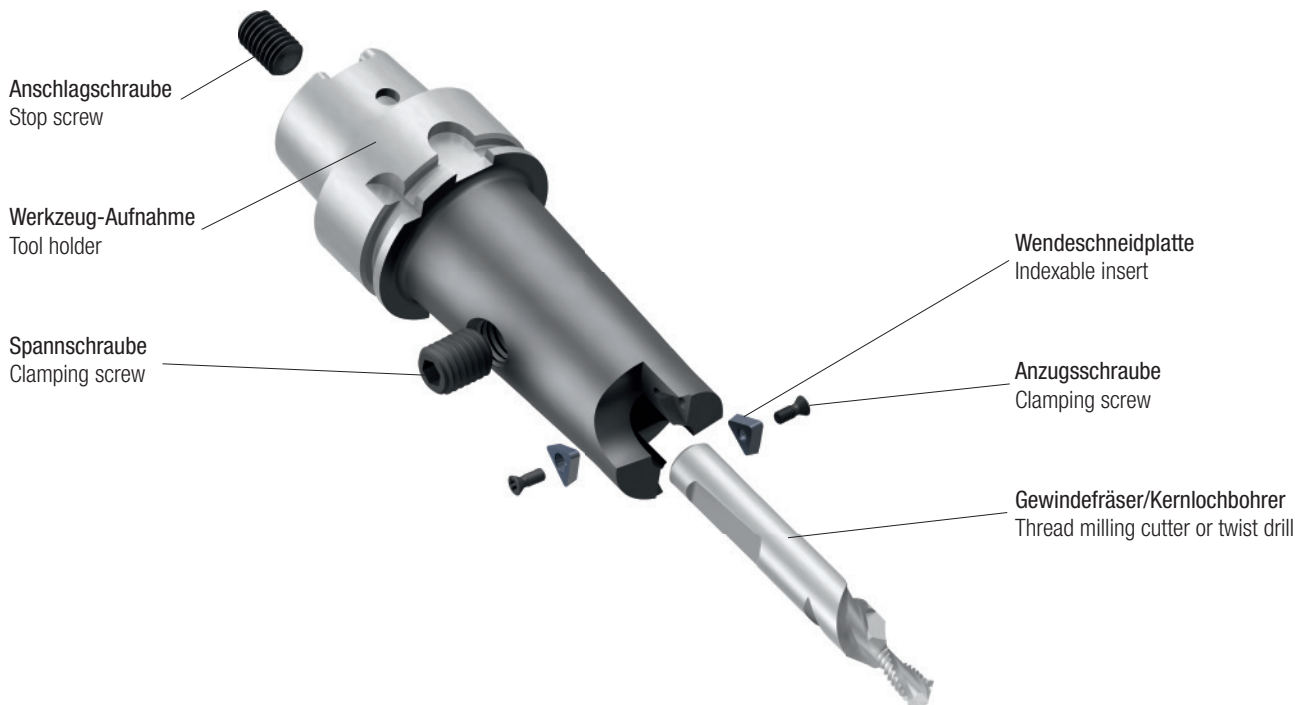

Steilkegelschäfte
ISO taper shanks



Kegel-Hohlschäfte
Hollow taper shanks



Anschluss für Plankopf
Connection for milling head



Anschluss für Wendeschneidplatten
Connection for indexable inserts

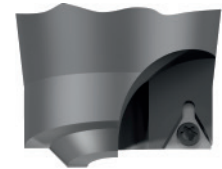
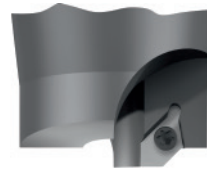

Zentrierring
Centering ring



Wendeschneidplatten zum Planen und Fasen
Indexable inserts for plane milling and chamfering



Wendeschneidplatten zum Planen
Indexable inserts for plane milling



Vollhartmetall-Planköpfe
Solid carbide milling heads

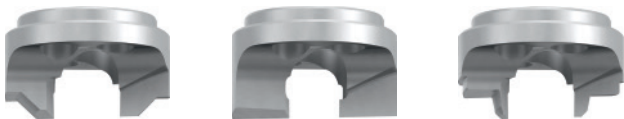

Gewindefräser oder Spiralbohrer
Thread milling cutters or twist drills



Product Finder

v_c / f_z

M

MF

UNC
UN, UNS

UNF
UNEF

G, Rp

NPT, NPTF
Rc, W

BSW, BSF

Pg

EG (STI)
SELF-LOCK

Tr

Zubehör
Accessories

Tech. Info

BGF

ZBGF

GSF

GF

GF-KEG

ZGF

ZIRK-GF

Gigant

MoSys



Product Finder

v_c / f_z

M

MF

UNC
UN, UNS

UNF
UNEF

G, Rp

NPT, NPTF
Rc, W

BSW, BSF

Pg

EG (STI)
SELF-LOCK

Tr

Zubehör
Accessories

Tech. Info

BGF

ZBGF

GSF

GF

GF-KEG

ZGF

ZIRK-GF

Gigant

MoSys

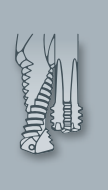

Zur Angebotsausarbeitung werden folgende Daten benötigt:

- Werkstückzeichnung mit evtl. Störkontur
- Maschinenseitige Aufnahme mit Kühlschmierstoff-Übergabe
- Detaillierte Senkkontur
- Herzustellende Gewindeabmessung einschließlich Gewindetiefe
- Bohrungsform (Durchgangsloch, Grundloch)
- Kernlochdurchmesser (falls vorhanden)
- Zu bearbeitender Werkstoff

For submitting an offer, we need the following information:

- Workpiece drawing with possible obstruction contours
- Shank connection on the machine side, with coolant supply
- Detailed countersink contour
- Size of the thread to be produced, including thread depth
- Type of hole (through hole or blind hole)
- Drilled hole diameter (if known)
- Workpiece material

Beispiel für Bearbeitung mit Vollhartmetall-Kopf

Example for machining with solid carbide head

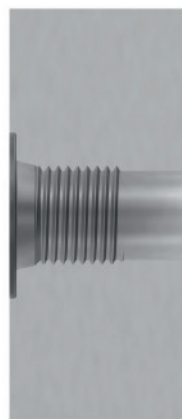
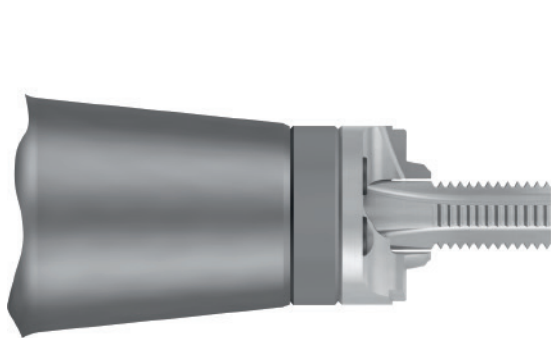

Beispiel für Bearbeitung mit Wendeschneidplatten

Example for machining with indexable inserts

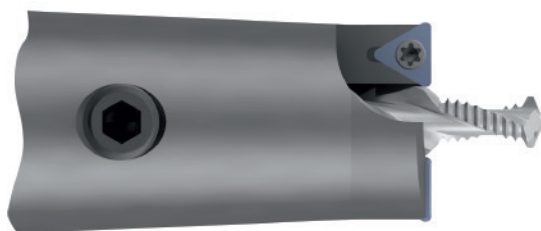

Technische Informationen

Technical Information

Seite · Page

3.1	Charakteristik und Vorteile des GewindefräSENS Characteristics and advantages of thread milling	450
3.2	EMUGE Gewindefräser-Typen Our EMUGE thread milling cutter types	451 - 455
3.3	Mögliche Modifikationen an Gewindefräsern Possible modifications on thread milling cutters	456 - 457
3.4	Berechnung der Schnittdaten Calculation of cutting data	458
3.5	GewindefräSverfahren (Rechtsgewinde) Thread milling processes (right-hand thread)	459
3.6	Probleme, mögliche Ursachen und Abhilfen beim GewindefräSEN Problems, possible causes and solutions in thread milling	460 - 461
3.7	Programmierung Ein- und Ausfahren im Viertelkreis Programming of run-in and run-out in a quarter circle	462
3.8	Programmierbeispiele (DIN) Programming examples (DIN)	463 - 470
3.9	Technischer Fragebogen: GewindefräSEN Technical questionnaire: Thread milling	471 - 472

Product
Finder v_c / f_z

M

MF

UNC
UN, UNSUNF
UNEF

G, Rp

NPT, NPTF
Rc, W

BSW, BSF

Pg

EG (STI)
SELF-LOCK

Tr

Zubehör
Accessories

Tech. Info

BGF

ZBGF

GSF

GF

GF-KEG

ZGF

ZIRK-GF

Gigant

MoSys

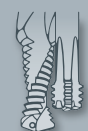

Die Technischen Informationen der jeweiligen Kapitel dieses Kataloges sind in vielen Landessprachen auch als separate Druckerzeugnisse verfügbar. Bitte wenden Sie sich an den für Sie zuständigen Vertriebspartner.

The technical information complementing the various chapters of this catalogue is available also as a separate printed booklet in many different languages. Please speak to your usual sales contact.

Product Finder

v_c / f_z

M

MF

UNC
UN, UNS

UNF
UNEF

G, Rp

NPT, NPTF
Rc, W

BSW, BSF

Pg

EG (STI)
SELF-LOCK

Tr

Zubehör
Accessories

Tech. Info

BGF

ZBGF

GSF

GF

GF-KEG

ZGF

ZIRK-GF

Gigant

MoSys

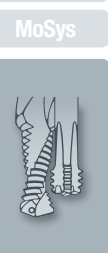

3.1 Charakteristik und Vorteile des Gewindefräsens

Gewindefräsen – eine Technologie, die Ihre Fertigungskosten spürbar senken kann!

Durch den verstärkten Einsatz der CNC-Technologie sind die Voraussetzungen für ein zukunftsorientiertes Verfahren zur Herstellung von Innen- und Außengewinden geschaffen worden.

Das Gewindefräsen lässt sich problemlos und prozesssicher praktizieren, wenn die CNC-Maschine über eine Steuerung mit 3D-Interpolation verfügt. Des Weiteren wird eine stabile und vibrationsfreie Werkzeug- und Werkstückschwingung sowie innere Kühlschmierstoff-Zufuhr (IKZ) benötigt.

Das Gewindefräsen ist in einer Vielzahl von Anwendungsfällen eine sinnvolle Alternative zum Gewindeschneiden oder Gewindeformen mit folgenden Vorteilen:

- Kurze Fertigungszeiten
- Hohe Prozesssicherheit
- Sehr gute Oberflächenqualität
- Verschiedene Bearbeitungsfunktionen mit einem Werkzeug
- Nutzbare Gewindetiefe bis zum Bohrungsgrund
- Keine hochwertigen Schmierstoffe notwendig
- Keine Spanprobleme, da nur kurze Frässpäne erzeugt werden
- Kein axiales Verschneiden (Vorweite) der Gewinde
- Universeller Einsatz in den verschiedensten Werkstoffen bis ca. 60 HRC
- Grund- und Durchgangslochgewinde mit einem Werkzeug
- Unabhängige Gewindeherstellung bezüglich Abmessung und Toleranz
- Ein Werkzeug für Rechts- und Linksgewinde
- Geringe Schnittkräfte
- Auch für dünnwandige Werkstücke geeignet

Sollten Sie keine oder nur wenig Erfahrung bei der Programmierung der Steuerung haben, stehen Ihnen unsere Techniker gerne mit Rat und Tat zur Seite. Wir sind auch gerne bereit, Sie hausintern oder vor Ort an konkreten Bearbeitungsbeispielen zu schulen.

Bitte sprechen Sie unsere Vertriebsmitarbeiter an.

3.1 Characteristics and advantages of thread milling

Thread milling – A technology which can reduce your production costs considerably!

With the more and more widespread use of CNC technology, the basic conditions for a future-oriented technique of producing internal and external threads have been created.

Thread milling can be practiced without any trouble and with a high degree of process safety if your CNC machine is provided with a control for 3D-interpolation. In addition to that, you need stable and vibration-free tool and workpiece clamping, and internal coolant supply.

Thread milling is, in a multitude of application cases, a highly recommendable alternative to tapping or cold-forming of threads, with the following advantages:

- Short production times
- High degree of process safety
- Very good surface quality
- Combination of different machining jobs with one tool
- Usable thread depth down to the very bottom of the hole
- No expensive lubricants are needed
- No chip problems, since only short milling chips are created
- No axial miscutting (overcut) of the thread
- Universal use in the most different materials up to approx. 60 HRC
- Blind hole and through hole threads produced with one tool
- Thread production independent of thread size and tolerance
- One tool only for right-hand and left-hand threads
- Low cutting forces
- Suitable also for thin-walled components

In case you should have little or no experience with the programming of the control, our technicians will be happy to help you by word and deed. We are also ready, at any time, to provide in-house or on-location training for you with practical machining examples.

Please contact our sales personnel.

3.2 EMUGE Gewindefräser-Typen

3.2 Our EMUGE thread milling cutter types

BGF

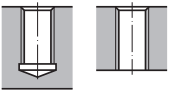
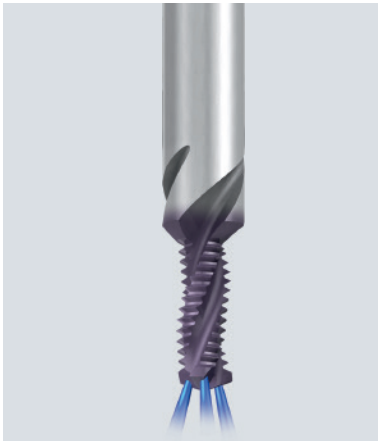
**Vollhartmetall-Bohrgewindefräser**

- Zur Herstellung von Innengewinden
- Für die Komplettbearbeitung von Kernloch, Senkfase und Gewinde in einem Arbeitsgang
- Abmessungsbezogenes Werkzeug mit korrigiertem Gewindeprofil

Ausführungen:

- 2-nutig: Bearbeitung ins volle Material
 3-nutig: Bearbeitung in vorgegossene Kernlöcher und ins volle Material
 4-nutig: Kürzere Bearbeitungszeiten (nur Gusseisen und Aluminium-Guss, kurzspanend)

Solid carbide drill thread mills

- For the production of internal threads
- For the complete machining of thread hole, chamfer and thread in one work process
- Tool for one single thread size with corrected thread profile

Designs:

- 2-fluted: For work in solid material
 3-fluted: For work in pre-cast thread holes and in solid material
 4-fluted: For shorter machining times (only for cast iron and cast aluminium, short-chipping)

ZBGF

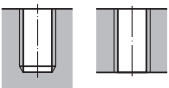
**Vollhartmetall-Zirkular-Bohrgewindefräser**

- Zur Herstellung von Innengewinden
- Für die Bearbeitung von Kernloch und Gewinde in einem Arbeitsgang
- Abmessungsübergreifendes und steigungsgebundenes Werkzeug mit korrigiertem Gewindeprofil

Ausführungen:

- ZBGF-T: Für Gewindetiefen bis 3 x D in Aluminium und Grauguss
 ZBGF-H: Für die Hartbearbeitung ab 44 HRC
 ZBGF-W: Für die verschiedensten Werkstoffe bis 44 HRC

Solid carbide circular drill thread mills

- For the production of internal threads
- For the machining of thread hole and thread in one work process
- Tool for different thread sizes but for one pitch only, with corrected thread profile

Designs:

- ZBGF-T: For thread depths up to 3 x D in aluminium and cast iron
 ZBGF-H: For hard machining from 44 HRC
 ZBGF-W: For the most different materials up to 44 HRC

GSF

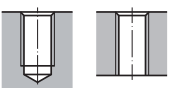
**Vollhartmetall-Gewindefräser mit Senkfase**

- Zur Herstellung von Innengewinden
- Für die Bearbeitung von Senkfase und Gewinde in einem Arbeitsgang
- Abmessungsbezogenes Werkzeug mit korrigiertem Gewindeprofil
- Voraussetzung ist ein vorgearbeitetes Kernloch

Solid carbide thread milling cutters with countersinking step

- For the production of internal threads
- For the machining of chamfer and thread in one work process
- Tool for one single thread size, with corrected thread profile
- A ready prepared thread hole is necessary

Product
Finder v_c / f_z

M

MF

UNC
UN, UNSUNF
UNEF

G, Rp

NPT, NPTF
Rc, W

BSW, BSF

Pg

EG (STI)
SELF-LOCK

Tr

Zubehör
Accessories

Tech. Info

BGF

ZBGF

GSF

GF

GF-KEG

ZGF

ZIRK-GF

Gigant

MoSys



- Product Finder
- v_c / f_z
- M
- MF
- UNC
UN, UNS
- UNF
UNEF
- G, Rp
- NPT, NPTF
Rc, W
- BSW, BSF
- Pg
- EG (STI)
SELF-LOCK
- Tr
- Zubehör
Accessories

3.2 EMUGE Gewindefräser-Typen

3.2 Our EMUGE thread milling cutter types

GSF-Z



Vollhartmetall-Gewindefräser mit Senkfase

- Zur Herstellung von Innengewinden
- Für die Bearbeitung von Senkfase und Gewinde in einem Arbeitsgang
- Abmessungsbezogenes Werkzeug mit korrigiertem Gewindeprofil
- Höhere Nutenzahl im Vergleich zum Typ GSF
- Optimierte Schneidengeometrie
- Voraussetzung ist ein vorgearbeitetes Kernloch

Solid carbide thread milling cutters with countersinking step

- For the production of internal threads
- For the machining of chamfer and thread in one work process
- Tool for one single thread size, with corrected thread profile
- Increased number of flutes compared with type GSF
- Optimised cutting geometry
- A ready prepared thread hole is necessary

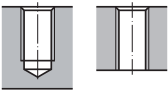

GF



Vollhartmetall-Gewindefräser

- Zur Herstellung von Innen- und Außengewinden
- Abmessungsübergreifendes Werkzeug mit Standard-Gewindeprofil (steigungsgebunden)
- Voraussetzung ist ein vorgearbeitetes Kernloch ggf. mit einer Ansenkung
- Um größere Profilüberfräsungen bei Innengewinden zu vermeiden, sollte der Fräserdurchmesser nicht größer als $\frac{2}{3}$ (bei Feingewinden $\frac{3}{4}$) des herzustellenden Gewindes sein
- Bei Außengewinden sollte der Fräserdurchmesser den herzustellenden Gewindedurchmesser nicht überschreiten

Solid carbide thread milling cutters

- For the production of internal and external threads
- Tool for different thread sizes with standard thread profile (but for one pitch only)
- A ready prepared thread hole is necessary, including chamfer if needed
- In order to avoid serious profile deviation in internal threads, the cutter diameter should not exceed $\frac{2}{3}$ (with fine threads, $\frac{3}{4}$) of the thread to be produced
- With external threads, the cutter diameter should not exceed the diameter of the thread to be produced

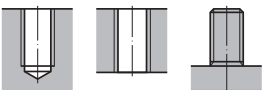

GF-Z



Vollhartmetall-Gewindefräser

- Zur Herstellung von Innengewinden
- Abmessungsübergreifendes Werkzeug mit Standard-Gewindeprofil (steigungsgebunden)
- Höhere Nutenzahl im Vergleich zum Typ GF
- Optimierte Schneidengeometrie
- Voraussetzung ist ein vorgearbeitetes Kernloch ggf. mit einer Ansenkung
- Um größere Profilüberfräsungen bei Innengewinden zu vermeiden, sollte der Fräserdurchmesser nicht größer als $\frac{2}{3}$ (bei Feingewinden $\frac{3}{4}$) des herzustellenden Gewindes sein

Solid carbide thread milling cutters

- For the production of internal threads
- Tool for different thread sizes with standard thread profile (but for one pitch only)
- Increased number of flutes compared with type GF
- Optimised cutting geometry
- A ready prepared thread hole is necessary, including chamfer if needed
- In order to avoid serious profile deviation in internal threads, the cutter diameter should not exceed $\frac{2}{3}$ (with fine threads, $\frac{3}{4}$) of the thread to be produced

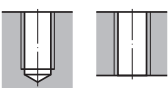

3.2 EMUGE Gewindefräser-Typen

3.2 Our EMUGE thread milling cutter types

GF-Vario-Z

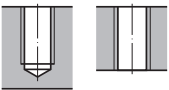
**Vollhartmetall-Gewindefräser variabel**

- Zur Herstellung von Innengewinden
- Abmessungsübergreifendes und steigungsgebundenes Werkzeug mit korrigiertem Gewindeprofil
- Hohe Nutenzahl
- Optimierte Schneidengeometrie
- Voraussetzung ist ein vorgearbeitetes Kernloch ggf. mit einer Ansenkung

Solid carbide thread milling cutters, variable

- For the production of internal threads
- Tool for different thread sizes, but for one pitch only, with corrected thread profile
- Large number of flutes
- Optimised cutting geometry
- A ready prepared thread hole is necessary, including chamfer if needed

GF-H

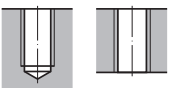
**Vollhartmetall-Gewindefräser für die Hartbearbeitung**

- Zur Herstellung von Innengewinden
- Abmessungsbezogenes Werkzeug mit korrigiertem Gewindeprofil
- Voraussetzung ist ein vorgearbeitetes Kernloch ggf. mit einer Ansenkung

Solid carbide thread milling cutters for hard machining

- For the production of internal threads
- Tool for one single thread size, with corrected thread profile
- A ready prepared thread hole is necessary, including chamfer if needed

GF-KEG

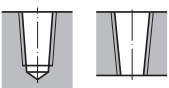
**Vollhartmetall-Gewindefräser für kegelige Gewinde**

- Zur Herstellung von kegeligen Innengewinden
- Abmessungs- bzw. steigungsgebundenes Werkzeug mit korrigiertem Gewindeprofil
- Voraussetzung ist ein zylindrisch oder besser ein kegelig vorgebohrtes Kernloch ggf. mit einer Ansenkung

Solid carbide thread milling cutters for tapered threads

- For the production of tapered internal threads
- Tool for one single thread size, resp. for one pitch only, with corrected thread profile
- A ready prepared cylindrical, or even better, tapered, thread hole is necessary, including chamfer if needed

Product
Finder v_c / f_z

M

MF

UNC
UN, UNSUNF
UNEF

G, Rp

NPT, NPTF
Rc, W

BSW, BSF

Pg

EG (STI)
SELF-LOCK

Tr

Zubehör
Accessories

Tech. Info

BGF

ZBGF

GSF

GF

GF-KEG

ZGF

ZIRK-GF

Gigant

MoSys



- Product Finder
- v_c / f_z
- M
- MF
- UNC
UN, UNS
- UNF
UNEF
- G, Rp
- NPT, NPTF
Rc, W
- BSW, BSF
- Pg
- EG (STI)
SELF-LOCK
- Tr
- Zubehör
Accessories

3.2 EMUGE Gewindefräser-Typen

3.2 Our EMUGE thread milling cutter types

ZGF

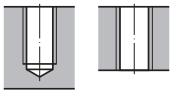

Vollhartmetall-Zirkulargewindefräser

- Zur Herstellung von Innengewinden ab M1
- **ZGF**
Abmessungs- und steigungsübergreifendes Werkzeug mit korrigiertem Gewindeprofil
- **ZGF-S-CUT**
Abmessungsbezogenes Werkzeug mit korrigiertem Gewindeprofil
- **ZGF-HCUT**
Abmessungsbezogenes Werkzeug mit korrigiertem Gewindeprofil
- Voraussetzung ist ein vorgearbeitetes Kernloch ggf. mit einer Ansenkung

Solid carbide circular thread milling cutters

- For the production of internal threads from M1
- **ZGF**
Tool for different thread sizes and pitches, with corrected thread profile
- **ZGF-S-CUT**
Tool for one single thread size, with corrected thread profile
- **ZGF-HCUT**
Tool for one single thread size, with corrected thread profile
- A ready prepared thread hole is necessary, including chamfer if needed

ZIRK-GF

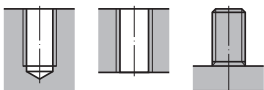

Zirkular-Gewindefräskörper

- Zur Herstellung von Innen- und Außengewinden
- Mit einer oder zwei Mehrzahnplatten
- Abmessungsübergreifendes und steigungsgebundenes Werkzeug
- Voraussetzung ist ein vorgearbeitetes Kernloch ggf. mit einer Ansenkung
- Um größere Profilüberfräsungen bei Innengewinden zu vermeiden, sollte der Fräserdurchmesser nicht größer als $\frac{2}{3}$ (bei Feingewinden $\frac{3}{4}$) des herzustellenden Gewindes sein

Circular thread milling bodies

- For the production of internal and external threads
- With one or two multi-tooth inserts
- Tool for different thread sizes, but for one pitch only
- A ready prepared thread hole is necessary, including chamfer if needed
- In order to avoid serious profile deviation in internal threads, the cutter diameter should not exceed $\frac{2}{3}$ (with fine threads, $\frac{3}{4}$) of the thread to be produced

ZIRK-GF

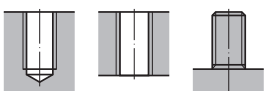

Zirkular-Gewindefräskörper

- Zur Herstellung von Innen- und Außengewinden
- Mit einer Einstechwendeplatte „3-Zahn“
- Abmessungs- und steigungsübergreifendes Werkzeug
- Voraussetzung ist ein vorgearbeitetes Kernloch ggf. mit einer Ansenkung
- Um größere Profilüberfräsungen bei Innengewinden zu vermeiden, sollte der Fräserdurchmesser nicht größer als $\frac{2}{3}$ (bei Feingewinden $\frac{3}{4}$) des herzustellenden Gewindes sein

Circular thread milling bodies

- For the production of internal and external threads
- With one infeed indexable insert, "3-tooth" design
- Tool for different thread sizes and pitches
- A ready prepared thread hole is necessary, including chamfer if needed
- In order to avoid serious profile deviation in internal threads, the cutter diameter should not exceed $\frac{2}{3}$ (with fine threads, $\frac{3}{4}$) of the thread to be produced

3.2 EMUGE Gewindefräser-Typen

3.2 Our EMUGE thread milling cutter types

Gigant

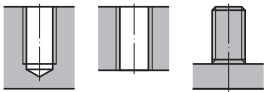
**Zirkular-Gewindefräskörper**

- Zur Herstellung von großen Innen- und Außengewinden
- Mit bis zu zehn 4-Zahn-Wendeplatten (steigungsübergreifend)
- Abmessungs- und steigungsübergreifendes Werkzeug
- Voraussetzung ist ein vorgearbeitetes Kernloch ggf. mit einer Ansenkung

Circular thread milling bodies

- For the production of large internal and external threads
- With up to ten 4-tooth indexable inserts (independent of pitch)
- Tool for different thread sizes and pitches
- A ready prepared thread hole is necessary, including chamfer if needed

Product
Finder v_c / f_z

M

MF

UNC
UN, UNSUNF
UNEF

G, Rp

NPT, NPTF
Rc, W

BSW, BSF

Pg

EG (STI)
SELF-LOCK

Tr

Zubehör
Accessories

Tech. Info

BGF

ZBGF

GSF

GF

GF-KEG

ZGF

ZIRK-GF

Gigant

MoSys



- Product Finder
- v_c / f_z
- M
- MF
- UNC
UN, UNS
- UNF
UNEF
- G, Rp
- NPT, NPTF
Rc, W
- BSW, BSF
- Pg
- EG (STI)
SELF-LOCK
- Tr
- Zubehör
Accessories

3.3 Mögliche Modifikationen an Gewindefräsern

3.3 Possible modifications on thread milling cutters

Stirrfase (ohne oder mit Stirnschnitt)

Face chamfer (with or without cutting face)

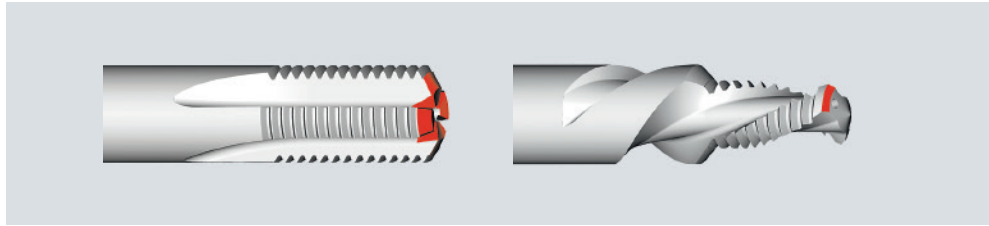

Geeignet für:

- Alle Typen GF und GSF
- Alle Typen BGF (Stirrfase am Bohrteil)

Suitable for:

- All types GF and GSF
- All types BGF (face chamfer on the drilling part)

Bemerkung:

- Stirrfase für zirkulares Anfasen des Kernloches
- Zusätzlicher Stirnschnitt für zirkulares Planfräsen

Note:

- Face chamfer for circular chamfering of the thread hole
- Additional cutting face for circular face milling

Tech. Info

Unvollständigen Gang entfernen

Removal of incomplete thread

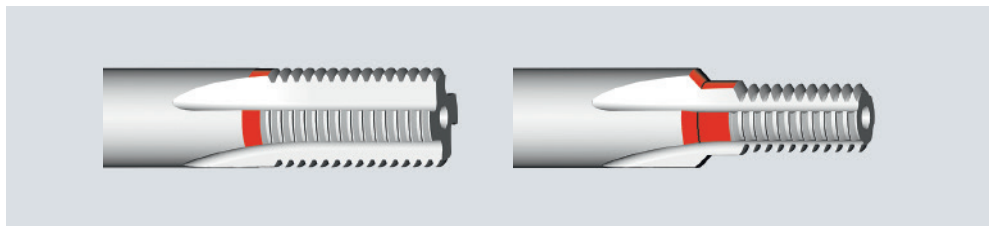

Geeignet für:

- Alle Typen GF, GSF und BGF

Suitable for:

- All types GF, GSF and BGF

Bemerkung:

- Am schaftseitigen Ende des Frästeils wird eine Stufe mit einer Länge von min. $1 \times P$ hinterschleifen
- Bei entsprechender Eintauchtiefe wird beim Gewindefräsen der unvollständige, gratbehaftete Gewindegang abgefräst (entfernt)

Note:

- At the rear end of the thread part, a step with a length of min. $1 \times P$ is relief-ground
- If the tool plunges to a correct depth during the thread milling process, the incomplete thread run-out with its burr is milled off (removed)



Halsfreischliff

Recessed neck

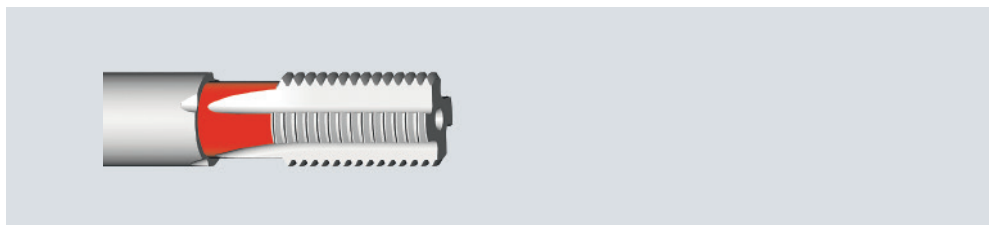

Geeignet für:

- Alle Typen GF und GSF (Senkfase entfällt)

Suitable for:

- All types GF and GSF (no countersinking step)

Bemerkung:

- Für größere Gewindetiefen (gesamte Gewindetiefe setzt sich aus zwei Fräsdurchläufen zusammen)
- Für einen konstanten Schnittdruck wird die Frästeillänge und die Halslänge im Verhältnis 1:1 aufgeteilt!
- Die Frästeillänge und der Versatz für einen zweiten Fräsdurchlauf sind immer ein ganzzahliges Vielfaches der Profilteilung

Note:

- For larger thread depths (total thread depth is achieved by a double milling process)
- For constant cutting pressure, the thread part length and the neck length are arranged in a ratio of 1:1!
- The thread part length and the offset for a second milling process are always a whole-number multiple of the thread pitch

3.3 Mögliche Modifikationen an Gewindfräsern

3.3 Possible modifications on thread milling cutters

AZR

Radial ausgesetzte Zahnreihen

Radially alternating tooth rows

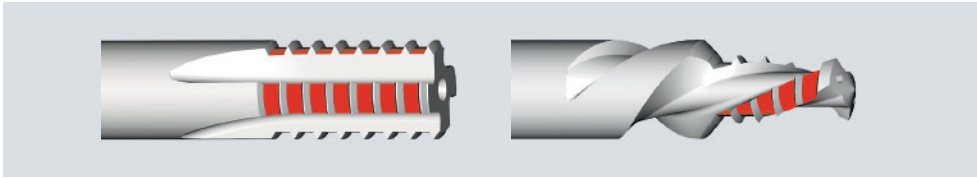

Geeignet für:

- Alle Typen GF, GSF und BGF

Bemerkung:

- Durch **AZR** werden die Seitenkräfte beim Gewindfräsen reduziert; die zyklisch fehlenden Gewindelücken werden durch zusätzliche zirkuläre Fräsumläufe gefräst

Eine nicht gezeigte Variante wäre auch **AZ** (abwechselnd ausgesetzte Zähne)

Vorteil:

- Zusätzliche zirkuläre Fräsumläufe entfallen; dadurch ergibt sich eine normale Einstichbreite am Bohrungsgrund bei BGF

Suitable for:

- All types GF, GSF and BGF

Note:

- AZR helps to reduce lateral forces in thread milling; the alternating missing gaps in the thread are produced by additional circular milling orbits

There is another variant, not shown here, called **AZ** (alternating teeth in a staggered sequence)

Advantage:

- No additional circular orbits are necessary; due to this, there is a perfectly normal recess depth at the hole bottom, if BGF type tools are used

IKZN

Innere Kühlschmierstoff-Zufuhr mit Austritt in den Nuten

Internal coolant supply exiting in the flutes



Geeignet für:

- Alle Typen GF und GSF

Bemerkung:

- Stirnseitig verschlossene Axialbohrung für die Bearbeitung von Durchgangslöchern
- Für maximale Stabilität des Frästeils sind die seitlichen Austrittsbohrungen axial versetzt angeordnet

Suitable for:

- All types GF and GSF

Note:

- Axial coolant bore closed up at the tool face for the production of through hole threads
- For maximum stability of the cutting part, the lateral coolant holes are axially staggered

Schaftkühlnuten

Coolant grooves along the shank

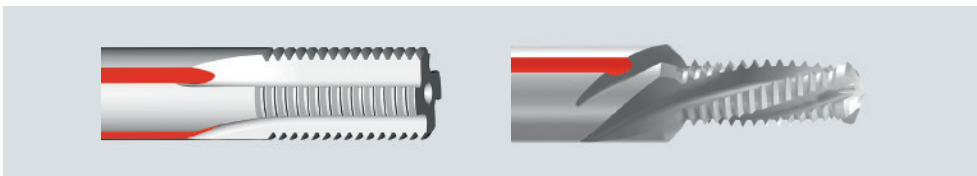

Geeignet für:

- Alle Typen GF, GSF und BGF

Bemerkung:

- Für die Bearbeitung von Durchgangslöchern
- Zusätzlich oder ersatzweise zu IKZ oder IKZN
- Ggf. unterstützend zur Kühlung der Senkfase bei GSF und BGF oder des Plansenkers bei MoSys-Anwendungen

Suitable for:

- All types GF, GSF and BGF

Note:

- For the production of through hole threads
- In addition or as an alternative to IKZ or IKZN
- Possible support in the cooling of the countersinking step of GSF and BGF type tools, or of the plane milling head in MoSys applications

Product
Finder v_c / f_z

M

MF

UNC
UN, UNSUNF
UNEF

G, Rp

NPT, NPTF
Rc, W

BSW, BSF

Pg

EG (STI)
SELF-LOCK

Tr

Zubehör
Accessories

Tech. Info

BGF

ZBGF

GSF

GF

GF-KEG

ZGF

ZIRK-GF

Gigant

MoSys



Product Finder

3.4 Berechnung der Schnittdaten

3.4 Calculation of cutting data

v_c / f_z

M

MF

UNC
UN, UNS

UNF
UNEF

G, Rp

NPT, NPTF
Rc, W

BSW, BSF

Pg

EG (STI)
SELF-LOCK

Tr

Zubehör
Accessories

Tech. Info

BGF

ZBGF

GSF

GF

GF-KEG

ZGF

ZIRK-GF

Gigant

MoSys



$$v_c = \frac{d_1 \cdot \pi \cdot n}{1000} \text{ [m/min]}$$

Schnittgeschwindigkeit v_c in m/min

d_1 = Frästeildurchmesser in mm
 n = Drehzahl in min^{-1}

Cutting speed v_c in m/min

d_1 = Milling part diameter in mm
 n = Speed in min^{-1} (rpm)

$$n = \frac{v_c \cdot 1000}{d_1 \cdot \pi} \text{ [min}^{-1}\text{]}$$

Drehzahl n in min^{-1}

d_1 = Frästeildurchmesser in mm
 v_c = Schnittgeschwindigkeit in m/min

Speed n in min^{-1} (rpm)

d_1 = Milling part diameter in mm
 v_c = Cutting speed in m/min

$$v_f = f_z \cdot Z \cdot n \text{ [mm/min]}$$

Vorschubgeschwindigkeit Kontur v_f in mm/min

f_z = Vorschub pro Zahn in mm
 Z = Anzahl der Nuten

Feed speed contour v_f in mm/min

f_z = Feed per tooth in mm
 Z = No. of flutes

$$v_{fM} = \frac{v_f \cdot (D - d_1)}{D} \text{ [mm/min]}$$

Vorschubgeschwindigkeit Mittelpunktsbahn (bei Innengewinde) v_{fM} in mm/min

v_f = Vorschubgeschwindigkeit in mm/min
 D = Gewinдененndurchmesser in mm
 d_1 = Frästeildurchmesser in mm

Feed speed centre orbit (with internal threads) v_{fM} in mm/min

v_f = Feed speed in mm/min
 D = Nominal thread diameter in mm
 d_1 = Milling part diameter in mm

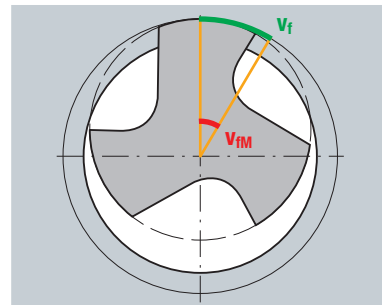

$$v_{fM} = \frac{v_f \cdot (D + d_1)}{D} \text{ [mm/min]}$$

Vorschubgeschwindigkeit Mittelpunktsbahn (bei Außengewinde) v_{fM} in mm/min

v_f = Vorschubgeschwindigkeit in mm/min
 D = Gewinдененndurchmesser in mm
 d_1 = Frästeildurchmesser in mm

Feed speed centre orbit (with external threads) v_{fM} in mm/min

v_f = Feed speed in mm/min
 D = Nominal thread diameter in mm
 d_1 = Milling part diameter in mm

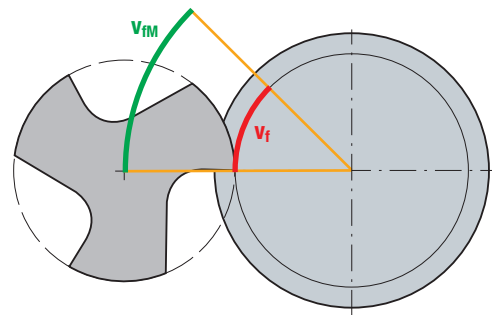

Der eingegebene Konturvorschub wird von der Maschine auf die Mittelpunktsbahn umgerechnet! Sollte dies nicht der Fall sein (erkennbar an einer wesentlich schnelleren Bearbeitungszeit bzw. Werkzeugbruch) muss der Mittelpunktsbahnvorschub eingegeben werden.

The contour feed entered is recalculated to the centre orbit by the machine! If this should not happen (to be recognised by the noticeably increased machining speed or by tool breakage), then the centre orbit feed must be entered manually.

3.5 Gewindefräsverfahren (Rechtsgewinde)

3.5 Thread milling processes (right-hand thread)

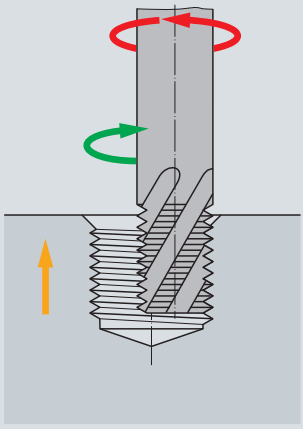
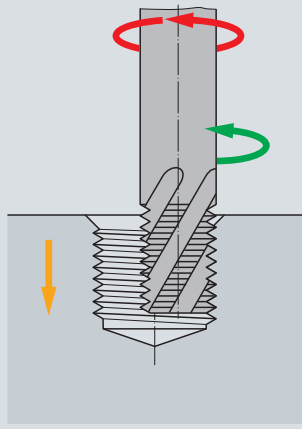
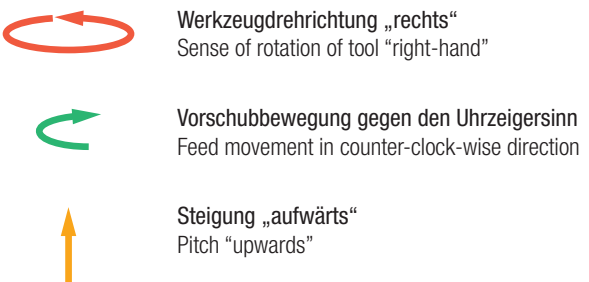
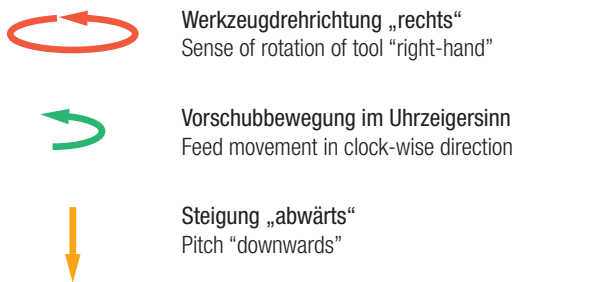
<p>Gleichlaufräsen Climb milling</p>	<p>Gegenlaufräsen Conventional milling</p>
	
	

Product Finder

v_c / f_z

M

MF

UNC
UN, UNS

UNF
UNEF

G, Rp

NPT, NPTF
Rc, W

BSW, BSF

Pg

EG (STI)
SELF-LOCK

Tr

Zubehör
Accessories

Tech. Info

BGF

ZBGF

GSF

GF

GF-KEG

ZGF

ZIRK-GF

Gigant

MoSys



Product Finder

v_c / f_z

M

MF

UNC
UN, UNS

UNF
UNEF

G, Rp

NPT, NPTF
Rc, W

BSW, BSF

Pg

EG (STI)
SELF-LOCK

Tr

Zubehör
Accessories

Tech. Info

BGF

ZBGF

GSF

GF

GF-KEG

ZGF

ZIRK-GF





Gigant

MoSys



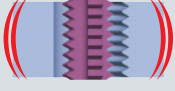

3.6 Probleme, mögliche Ursachen und Abhilfen beim Gewindefräsen

3.6 Problems, possible causes and solutions in thread milling

		Gewindefräsen allgemein Thread milling in general			
					
		Ratteln, Vibrationen Chattering, vibrations	Schlechte Werkstückoberfläche Bad surface quality on workpiece	übermäßiger Verschleiß Excessive wear	Schneidkanten- ausbrüche Chipped cutting edges
Mögliche Ursachen Possible causes		Abhilfen · Solutions			
~	Überprüfen Check				
↑	Steigern, erhöhen Increase				
↓	Vermindern Decrease				
GL	Gleichlaufräsen Climb milling				
GG	Gegenlaufräsen Conventional milling				
	Schnittgeschwindigkeit Cutting speed	~	~	↓	
	Vorschub pro Zahn Feed per tooth	~	~	↑	↓
	Stabilität (Werkstück/Werkstückspannung) Stability (workpiece/workpiece clamping)	↑	↑	↑	↑
	Stabilität (Werkzeug/Maschine) Stability (tool/machine)	↑	↑	↑	↑
	Auskraglänge Protruding length (of tool)	↓	↓	↓	~
	Werkzeugspirale (Drallnut) Tool helix (spiral flutes)	↑	↑	~	~
	Rundlaufgenauigkeit Concentricity	~	~	~	
	Beschichtung Coating			↑	↑
	Fräsverfahren/Programm/programmierter Radius Milling process/programme/programmed radius			GL	GL
	Einsatzbereich (Durchmesser-Verhältnis) Work case (relation of tool/thread diameters)				
	Werkzeugwechsel Tool change				
	NC-Achsen/Bahngeschwindigkeit (Rechner) NC axis/path speed (computer)	~	~	~	~
	Bohrvorschub (Entspanen) Drilling speed (remove chips)				
	Kühlschmierstoff-Druck/Austrittsbohrung Coolant-lubricant pressure (exit bore)			~	~

3.6 Probleme, mögliche Ursachen und Abhilfen beim Gewindefräsen

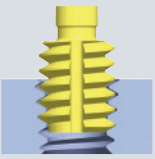
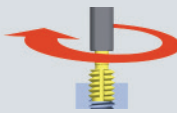
3.6 Problems, possible causes and solutions in thread milling

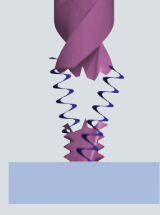
Gewindefräsen allgemein Thread milling in general		Bohrgewindefräsen Drill thread milling		
				
Gewinde wird konisch (Lehre klemmt auf Tiefe) Tapered thread shape (gauge jams after reaching a certain depth)	Geringe Toleranz von Gut- zu Ausschuss-Lehrung Small difference between go and no-go gauging	Markierung im Einfahrbereich Marks in the run-in area	Zahnausbrüche am Bohrgewindefräser Tooth chipping on the drill thread mill	Werkzeugbruch beim Bohren Tool breakage during the drilling process
Abhilfen · Solutions				
			~	
↓			~	
↑		~		
↑		~		
↓				
~				
	~		~	~
GG		~	~	
	~			
	~			
~		~	~	
			~	↓ ~
			~	~

- Product Finder
- v_c / f_z
- M
- MF
- UNC
UN, UNS
- UNF
UNEF
- G, Rp
- NPT, NPTF
Rc, W
- BSW, BSF
- Pg
- EG (STI)
SELF-LOCK
- Tr
- Zubehör
Accessories
- Tech. Info
- BGF
- ZBGF
- GSF
- GF
- GF-KEG
- ZGF
- ZIRK-GF
- Gigant
- MoSys



- Product Finder
- v_c / f_z
- M
- MF
- UNC
UN, UNS
- UNF
UNEF
- G, Rp
- NPT, NPTF
Rc, W
- BSW, BSF
- Pg
- EG (STI)
SELF-LOCK
- Tr
- Zubehör
Accessories
- Tech. Info
- BGF
- ZBGF
- GSF
- GF
- GF-KEG
- ZGF
- ZIRK-GF
- Gigant
- MoSys

3.7 Programmierung Ein- und Ausfahren im Viertelkreis

3.7 Programming of run-in and run-out in a quarter circle

- Wird verwendet, wenn der Abstand zwischen Gewindefräser und Kernlochwand mindestens 1 x Steigung beträgt
- Programmierung nach DIN 66025
- Gleichlaufräsen
- Inkrementaler Aufbau an der Gewindekontur
- Unterprogramm zur Abarbeitung des Gewindes

- To be used if the distance between thread milling cutter and thread hole wall is 1 x pitch as a minimum
- Programming acc. DIN 66025
- Climb milling
- Incremental construction along the thread contour
- Sub-programme for processing the thread

Gewinde: M20 x 1,5 – Gewindetiefe 16 mm
Werkzeug: GF-VHM-R30-1KZ-HB (Z4)
Artikel-Nr.: GF162121.9514

Thread: M20 x 1,5 – Thread depth 16 mm
Tool: GF-VHM-R30-1KZ-HB (Z4)
Article no.: GF162121.9514

N 10	G 54	G 90	G 00	X...	Y...	Z 2	S 2500	T 01	M 03	Startpunkt · Start point ■ = Sicherheitsabstand 2 mm · Safety distance 2 mm
N 20	G 91	G 00				Z -18				Gewindetiefe abfahren · Run down to thread depth ■ = Sicherheitsabstand + Gewindetiefe · Safety distance + thread depth
N 30	G 01	Y 0,75		F 200						■ = 1/2 Steigung verfahren · Relocate by 1/2 pitch
N 40	G 41	G 01		X 9,25						■ = (Nenndurchm. – Steigung) / 2 · (Nominal dia. – pitch) / 2
N 50	G 03			X -9,25	Y 9,25	Z 0,375	I -9,25	J 0		■ = (Nenndurchm. – Steigung) / 2 · (Nominal dia. – pitch) / 2 ■ = Steigung / 4 · Pitch / 4
N 60	G 03			X 0	Y 0	Z 1,5	I 0	J -10		■ = Steigung · Pitch ■ = Nenndurchm. / 2 · Nominal dia. / 2
N 70	G 03			X -9,25	Y -9,25	Z 0,375	I 0	J -9,25		■ = (Nenndurchm. – Steigung) / 2 · (Nominal dia. – pitch) / 2 ■ = Steigung / 4 · Pitch / 4
N 80	G 00	G 40		X 9,25	Y -0,75					■ = (Nenndurchm. – Steigung) / 2 · (Nominal dia. – pitch) / 2 ■ = 1/2 Steigung verfahren · Relocate by 1/2 pitch
N 90	G 90					Z 2				■ = Endpunkt bzw. Ausgangspunkt · Finish point resp. point of origin

Programmablauf

Programme sequence

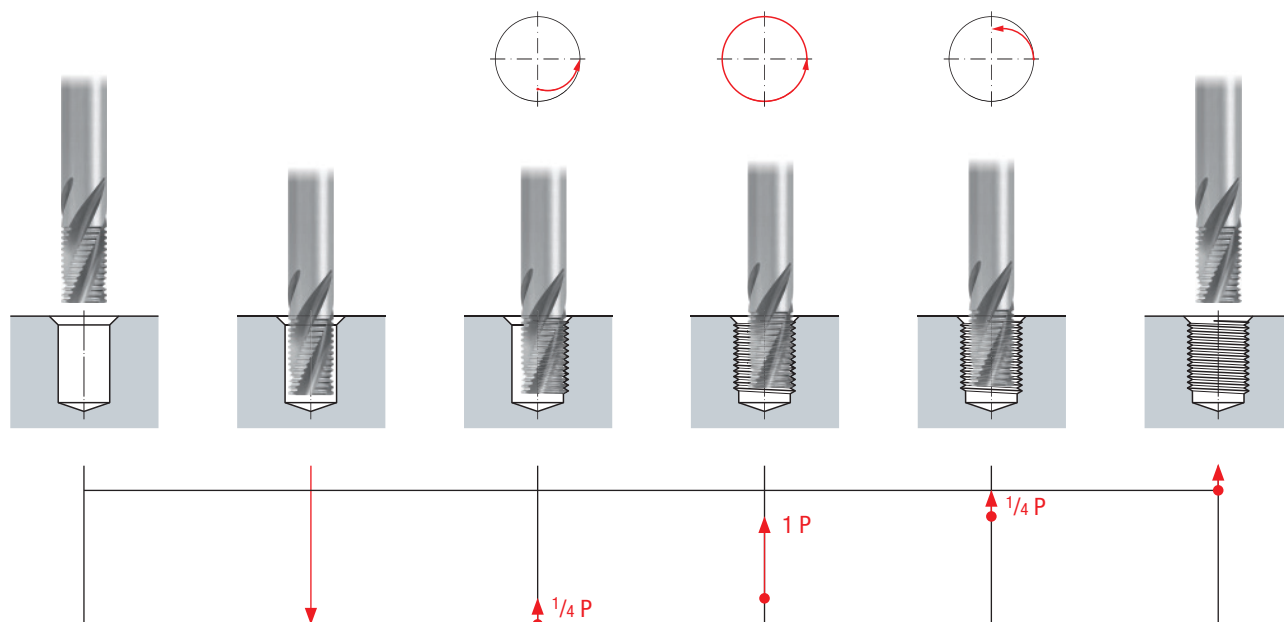

Programmierhilfen zum Gewindefräsen für DIN- und Heidenhain-Steuerungen sind auf www.emuge.de als Download verfügbar.

Programming support for thread milling with DIN and Heidenhain controls is available for download on www.emuge.de.

3.8 Programmierbeispiele (DIN)

Werkzeug: BGF-Z2 – 1,5 x D

3.8 Programming examples (DIN)

Tool: BGF-Z2 – 1.5 x D

Gewinde-Abmessung: Thread dimension:	M10 - 6H
Gewinde-Nenndurchmesser D: Nominal thread diameter D:	10,000 mm
Gewindesteigung P: Thread pitch P:	1,500 mm
Kernlochdurchmesser D₁: Drilled hole diameter D ₁ :	8,500 mm
Bohr-/ Senktiefe l_E: Drilling/Countersinking depth l _E :	19,100 mm
Werkstoff: Material:	GAISI9
Werkzeug-Abmessungen: Tool dimensions:	∅ 8,2 x 19,1 x 79 mm
Schneidstoff: Cutting material:	VHM
Beschichtung: Coating:	TICN
Artikel-Nr.: Article no.:	GF422206.0100
Zähnezahl Z: No. of teeth Z:	2
Fräserdurchmesser d₁: Cutter diameter d ₁ :	8,200 mm
Fräserradiuskorrektur k¹⁾: Cutter radius compensation k ¹⁾ :	0,100 mm
zu programmierender Fräserradius²⁾: Cutter radius to be programmed ²⁾ :	4,000 mm
Schnittgeschwindigkeit v_c: Cutting speed v _c :	250 m/min
Vorschub pro Umdrehung (Bohren/Senken) f_b: Feed per revolution (Drilling/countersinking) f _b :	0,250 mm
Vorschub pro Zahn (Fräsen) f_z: Feed per tooth (milling) f _z :	0,100 mm
Drehzahl n: Speed n:	S = 9709 min ⁻¹
Vorschubgeschwindigkeit (Bohren/Senken) v_b: Feed speed (Drilling/countersinking) v _b :	F = 2427 mm/min
Vorschubgeschwindigkeit (Kontur) v_f: Feed speed (contour) v _f :	F = 1942 mm/min
Vorschubgeschwindigkeit (Mittelpunktsbahn) v_{fM}: Feed speed (centre point) v _{fM} :	F = 350 mm/min

(gemessen am Frästeil)
(measured on the cutting part)

$$(0,01 \cdot D)$$

$$(0,5 \cdot d_1 - k)$$

$$n = \frac{v_c \cdot 1000}{d_1 \cdot \pi}$$

$$v_b = f_b \cdot n$$

$$v_f = f_z \cdot Z \cdot n$$

$$v_{fM} = \frac{v_f \cdot (D - d_1)}{D}$$

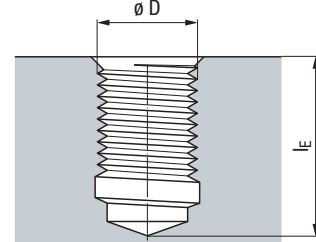
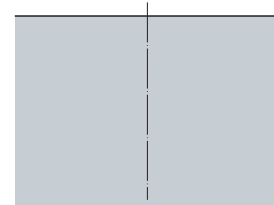
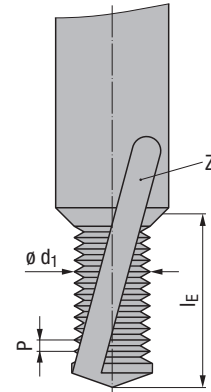

CNC-Innengewindefräsen (im Gleichlauf, an der Kontur, inkremental, nach DIN 66025)

CNC internal thread milling (climb milling, on the contour, incremental, acc. DIN 66025)

N 10	G 54	G 90	G 00	X...	Y...	Z 2	S 9709	T 01 ²⁾	M03
N 20	G 91	G 01	Z -21,100	F 2427 (Bohren/Senken · Drilling/countersinking)					
N 30	G 01	Z 0,500							
N 40	G 41	Y -4,250	F 1942 (Fräsen, Kontur · Milling, contour)				[F 350] ³⁾ (Mittelpunkt · Centre point)		
N 50	G 03	X 0	Y 9,250	Z 0,750	I 0	J 4,625			
N 60	G 03	X 0	Y 0	Z 1,500	I 0	J -5,000			
N 70	G 03	X 0	Y -9,250	Z 0,750	I 0	J -4,625			
N 80	G 00	G 40	X 0	Y 4,250					
N 90	G 90	Z 2							

Zerspanzeit t_n:
Machining time t_n: **2,3 sec.**

¹⁾ Der über die Zahnspitze des Gewindeteils gemessene Fräserradius ist um den Betrag der Fräserradiuskorrektur zu reduzieren. Hiermit wird eine Zustellung auf Mitte der „6H/ISO2-Muttertoleranz“ erreicht. Die Fräserradiuskorrektur hängt aber auch von der radialen Verdrängung des Werkzeuges ab (Festigkeit des zu fräsenden Materials und Auskraglänge).

²⁾ Der zu programmierende Fräserradius ist üblicherweise im Werkzeugspeicher enthalten.

³⁾ Bei Steuerungen, welche die Berechnung des Mittelpunktsvorschubs nicht selbstständig durchführen, müssen die Vorschubwerte in Klammern verwendet werden.

¹⁾ The cutter radius measured over the tooth crests of the threaded part must be reduced by the amount of the cutter radius compensation. This is necessary to achieve a depth of cut to the middle of the 6H/ISO2 nut tolerance. Please note, however, that this also depends on the radial deflection of the tool (tensile strength of the material, projection length of the tool).

²⁾ The cutter radius to be programmed is normally included in the tool memory.

³⁾ If your control does not calculate the centre point feed automatically please use the feed values printed in brackets.

Product Finder

v_c / f_z

M

MF

UNC
UN, UNS

UNF
UNEF

G, Rp

NPT, NPTF
Rc, W

BSW, BSF

Pg

EG (STI)
SELF-LOCK

Tr

Zubehör
Accessories

Tech. Info

BGF

ZBGF

GSF

GF

GF-KEG

ZGF

ZIRK-GF

Gigant

MoSys



Product Finder

v_c / f_z

3.8 Programmierbeispiele (DIN)

Werkzeug: ZBGF-W

3.8 Programming examples (DIN)

Tool: ZBGF-W

M	Gewinde-Abmessung: Thread dimension:	M12 x 1,5 - 6H
MF	Gewinde-Nenndurchmesser D: Nominal thread diameter D:	12,000 mm
UNC UN, UNS	Gewindesteigung P: Thread pitch P:	1,500 mm
UNF UNEF	Kernlochdurchmesser D₁: Drilled hole diameter D ₁ :	10,500 mm
G, Rp	Gewindetiefe b ³⁾: Thread depth b ³⁾ :	15,000 mm
NPT, NPTF Rc, W	Länge l₂: Length l ₂ :	6,000 mm
BSW, BSF	Werkstoff: Material:	GAISI9
Pg	Werkzeug-Abmessungen: Tool dimensions:	ø 7,75 x 6,9 x 76 mm
EG (STI) SELF-LOCK	Schneidstoff: Cutting material:	VHM
Tr	Beschichtung: Coating:	TIALN-T4
Zubehör Accessories	Artikel-Nr.: Article no.:	GF732257.0100
Tech. Info	Zähnezahl Z: No. of teeth Z:	4
BGF	Fräserdurchmesser d₁: Cutter diameter d ₁ :	7,750 mm
ZBGF	Fräserradiuskorrektur k ¹⁾: Cutter radius compensation k ¹⁾ :	0,120 mm
GSF	zu programmierender Fräserradius ¹⁾: Cutter radius to be programmed ¹⁾ :	3,755 mm
GF	Schnittgeschwindigkeit v_c: Cutting speed v _c :	250 m/min
GF-KEG	Vorschub pro Zahn (Fräsen) f_z: Feed per tooth (milling) f _z :	0,100 mm
ZGF	Drehzahl n: Speed n:	S = 10273 min ⁻¹
ZIRK-GF	Vorschubgeschwindigkeit (Kontur) v_f: Feed speed (contour) v _f :	F = 4109 mm/min
Gigant	Vorschubgeschwindigkeit (Mittelpunktsbahn) v_{fM}: Feed speed (centre point) v _{fM} :	F = 1455 mm/min
MoSys		

(gemessen am Frästeil)
(measured on the cutting part)

(je nach Einsatzfall)
(acc. work case)

(0,5 · d₁ - k)

$$n = \frac{v_c \cdot 1000}{d_1 \cdot \pi}$$

$$v_f = f_z \cdot Z \cdot n$$

$$v_{fM} = \frac{v_f \cdot (D - d_1)}{D}$$

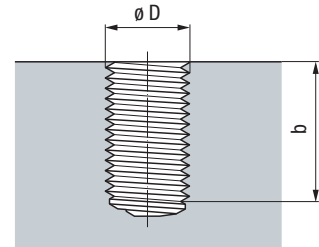
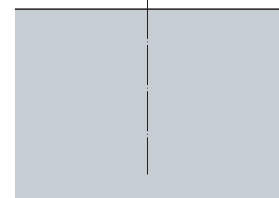
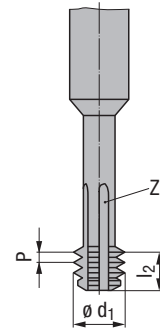

CNC-Innengewindefräsen (im Gegenlauf, an der Kontur, inkremental, nach DIN 66025)

CNC internal thread milling (conventional milling, on the contour, incremental, acc. DIN 66025)

N 10	G 54	G 90	G 00	X...	Y...	Z 1,500	S 10273	T 01 ²⁾	M 03
N 20	G 91								
N 30	G 42	G 01	X 0	Y -6	F 4109 (Kontur · contour)		[F 1455] ⁴⁾	(Mittelpunkt · Centre point)	
N 40	G 02	G 01	X 0	Y 0	Z -1,500	I 0	J 6,000		
... ⁵⁾									
N 50	G 40	G 01	X 0	Y 6					
N 70	G 90	G 00	Z 1,5						

Zerspanzeit t_h: Machining time t _h :	8,3 sec.
Anzahl der Gewindegänge ⁵⁾: Number of threads ⁵⁾ :	14

¹⁾ Der zu programmierende Fräserradius ist je nach Einsatzfall zu korrigieren, bis das Gewinde die gewünschte Muttertoleranz, z.B. 6H/ISO2 erreicht. Die Fräserradiuskorrektur hängt aber auch von der radialen Verdrängung des Werkzeugs ab (Festigkeit des zu fräsenden Materials und Auskraglänge).

²⁾ Der zu programmierende Fräserradius ist üblicherweise im Werkzeugspeicher enthalten.

³⁾ Die eingegebene Gewindetiefe b muss durch die Steigung P teilbar sein.

⁴⁾ Bei Steuerungen, welche die Berechnung des Mittelpunktvorschubs nicht selbstständig durchführen, müssen die Vorschubwerte in Klammern verwendet werden.

⁵⁾ Satz N 40 muss mit Anzahl der Gewindegänge wiederholt werden.

¹⁾ The cutter radius to be programmed must be corrected, depending on the work case, until the thread achieves the required nut tolerance, e.g. 6H/ISO2. Please note, however, that this also depends on the radial deflection of the tool (tensile strength of the material, projection length of the tool).

²⁾ The cutter radius to be programmed is normally included in the tool memory.

³⁾ The thread depth b as entered must be divisible by the pitch P.

⁴⁾ If your control does not calculate the centre point feed automatically please use the feed values printed in brackets.

⁵⁾ Block N 40 must be repeated with the number of threads.

3.8 Programmierbeispiele (DIN)

Werkzeug: GSF – 2 x D

3.8 Programming examples (DIN)

Tool: GSF – 2 x D

Gewinde-Abmessung: Thread dimension:	M10 - 6H
Gewinde-Nenndurchmesser D: Nominal thread diameter D:	10,000 mm
Gewindesteigung P: Thread pitch P:	1,500 mm
Kernlochdurchmesser D₁: Drilled hole diameter D ₁ :	8,500 mm
Senktiefe l_S: Countersinking depth l _S :	21,200 mm
Werkstoff: Material:	GAISI9

Werkzeug-Abmessungen: Tool dimensions:	∅ 8,2 x 21,2 x 80 mm
Schneidstoff: Cutting material:	VHM
Beschichtung: Coating:	TICN
Artikel-Nr.: Article no.:	GF332106.0100
Zähnezahl Z: No. of teeth Z:	3
Fräserdurchmesser d₁: Cutter diameter d ₁ :	8,200 mm

(gemessen am Frästeil)
(measured on the cutting part)

Fräserradiuskorrektur k¹⁾: Cutter radius compensation k ¹⁾ :	0,100 mm	(0,01 · D)
--	----------	------------

zu programmierender Fräserradius²⁾: Cutter radius to be programmed ²⁾ :	4,000 mm	(0,5 · d ₁ - k)
---	----------	----------------------------

Schnittgeschwindigkeit v_c: Cutting speed v _c :	250 m/min
--	-----------

Vorschub pro Umdrehung (Senken) f_s: Feed per revolution (countersinking) f _s :	0,200 mm
--	----------

Vorschub pro Zahn (Fräsen) f_z: Feed per tooth (milling) f _z :	0,100 mm
---	----------

Drehzahl n: Speed n:	S = 9709 min ⁻¹	$n = \frac{v_c \cdot 1000}{d_1 \cdot \pi}$
--------------------------------	----------------------------	--

Vorschubgeschwindigkeit (Senken) v_S: Feed speed (countersinking) v _S :	F = 1942 mm/min	$v_s = f_s \cdot n$
--	-----------------	---------------------

Vorschubgeschwindigkeit (Kontur) v_f: Feed speed (contour) v _f :	F = 2913 mm/min	$v_f = f_z \cdot Z \cdot n$
---	-----------------	-----------------------------

Vorschubgeschwindigkeit (Mittelpunktsbahn) v_{FM}: Feed speed (centre point) v _{FM} :	F = 524 mm/min	$v_{FM} = \frac{v_f \cdot (D - d_1)}{D}$
--	----------------	--

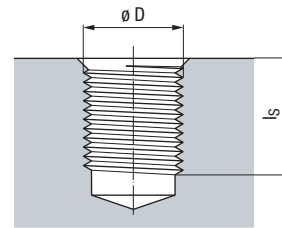
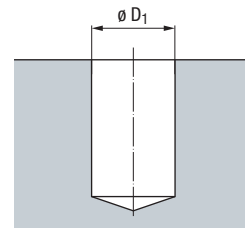
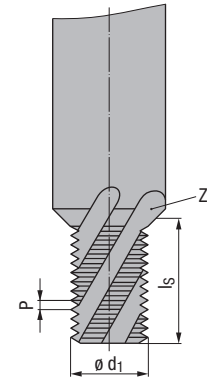

CNC-Innengewindefräsen (im Gleichlauf, an der Kontur, inkremental, nach DIN 66025)

CNC internal thread milling (climb milling, on the contour, incremental, acc. DIN 66025)

N 10	G 54	G 90	G 00	X...	Y...	Z 2	S 9709	T 01 ²⁾	M 03
N 20	G 91	Z -21,200							
N 30	G 01	Z -2			F 1942 (Senken · countersinking)				
N 40	G 01	Z 0,500							
N 50	G 41	Y -4,250			F 2913 (Fräsen, Kontur · Milling, contour)		[F 524] ³⁾	(Mittelpunkt · Centre point)	
N 60	G 03	X 0	Y 9,250	Z 0,750	I 0	J 4,625			
N 70	G 03	X 0	Y 0	Z 1,500	I 0	J -5,000			
N 80	G 03	X 0	Y -9,250	Z 0,750	I 0	J -4,625			
N 90	G 00	G 40	X 0	Y 4,250					
N 100	G 90	Z 2							

Zerspanzeit t_n: Machining time t _n :	1,3 sec.
--	-----------------

¹⁾ Der über die Zahnschneidspitze des Gewindeteils gemessene Fräserradius ist um den Betrag der Fräserradiuskorrektur zu reduzieren. Hiermit wird eine Zustellung auf Mitte der „6H/ISO2-Muttertoleranz“ erreicht. Die Fräserradiuskorrektur hängt aber auch von der radialen Verdrängung des Werkzeuges ab (Festigkeit des zu fräsenden Materials und Auskraglänge).

²⁾ Der zu programmierende Fräserradius ist üblicherweise im Werkzeugspeicher enthalten.

³⁾ Bei Steuerungen, welche die Berechnung des Mittelpunktsvorschubs nicht selbstständig durchführen, müssen die Vorschubwerte in Klammern verwendet werden.

¹⁾ The cutter radius measured over the tooth crests of the threaded part must be reduced by the amount of the cutter radius compensation. This is necessary to achieve a depth of cut to the middle of the 6H/ISO2 nut tolerance. Please note, however, that this also depends on the radial deflection of the tool (tensile strength of the material, projection length of the tool).

²⁾ The cutter radius to be programmed is normally included in the tool memory.

³⁾ If your control does not calculate the centre point feed automatically please use the feed values printed in brackets.

- Product Finder
- v_c / f_z
- M
- MF
- UNC
UN, UNS
- UNF
UNEF
- G, Rp
- NPT, NPTF
Rc, W
- BSW, BSF
- Pg
- EG (STI)
SELF-LOCK
- Tr
- Zubehör
Accessories
- Tech. Info**
- BGF
- ZBGF
- GSF
- GF
- GF-KEG
- ZGF
- ZIRK-GF
- Gigant
- MoSys



Product Finder

v_c / f_z

3.8 Programmierbeispiele (DIN)

Werkzeug: GF

3.8 Programming examples (DIN)

Tool: GF

M

Gewinde-Abmessung: Thread dimension:	M30 x 1,5 - 6H
--	----------------

MF

Gewinde-Nenndurchmesser D: Nominal thread diameter D:	30,000 mm
---	-----------

UNC
UN, UNS

Gewindesteigung P: Thread pitch P:	1,500 mm
--	----------

UNF
UNEF

Kernlochdurchmesser D_1: Drilled hole diameter D_1 :	28,500 mm
---	-----------

G, Rp

Gewindetiefe b: Thread depth b:	25,000 mm
---	-----------

NPT, NPTF
Rc, W

Werkstoff: Material:	GAISI9
--------------------------------	--------

BSW, BSF

Werkzeug-Abmessungen: Tool dimensions:	$\varnothing 20 \times 32 \times 105$ mm
--	--

Pg

Schneidstoff: Cutting material:	VHM
---	-----

EG (STI)
SELF-LOCK

Beschichtung: Coating:	TICN
----------------------------------	------

Tr

Artikel-Nr.: Article no.:	GF163156.9514
-------------------------------------	---------------

Zubehör
Accessories

Zähnezahl Z: No. of teeth Z:	5
--	---

Tech. Info

Fräserdurchmesser d_1: Cutter diameter d_1 :	20,000 mm	(gemessen am Frästeil) (measured on the cutting part)
---	-----------	--

BGF

Fräserradiuskorrektur k^1: Cutter radius compensation k^1 :	0,075 mm	$(0,05 \cdot P)$
--	----------	------------------

ZBGF

zu programmierender Fräserradius 2^2: Cutter radius to be programmed 2^2 :	9,925 mm	$(0,5 \cdot d_1 - k)$
---	----------	-----------------------

GSF

Schnittgeschwindigkeit v_c: Cutting speed v_c :	250 m/min
--	-----------

GF

Vorschub pro Zahn (Fräsen) f_z: Feed per tooth (milling) f_z :	0,100 mm
---	----------

GF-KEG

Drehzahl n: Speed n:	$S = 3981 \text{ min}^{-1}$	$n = \frac{v_c \cdot 1000}{d_1 \cdot \pi}$
--------------------------------	-----------------------------	--

ZIRK-GF

Vorschubgeschwindigkeit (Kontur) v_f: Feed speed (contour) v_f :	$F = 1990 \text{ mm/min}$	$v_f = f_z \cdot Z \cdot n$
---	---------------------------	-----------------------------

Gigant

Vorschubgeschwindigkeit (Mittelpunktsbahn) v_{fM}: Feed speed (centre point) v_{fM} :	$F = 663 \text{ mm/min}$	$v_{fM} = \frac{v_f \cdot (D - d_1)}{D}$
--	--------------------------	--

MoSys

CNC-Innengewindefräsen (im Gleichlauf, an der Kontur, inkremental, nach DIN 66025)

CNC internal thread milling (climb milling, on the contour, incremental, acc. DIN 66025)

N 10	G 54	G 90	G 00	X...	Y...	Z 2	S 3981	T 01 ²⁾	M 03
N 20	G 91	G 00	Z -27						
N 30	G 01	Y 0,750		F 1990 (Kontur · Contour)			[F 663] ³⁾	(Mittelpunkt · Centre point)	
N 40	G 41	G 01	X 14,25						
N 50	G 03	X -14,250	Y 14,25	Z 0,375	I -14,250	J 0			
N 60	G 03	X 0	Y 0	Z 1,5	I 0	J -15,000			
N 70	G 03	X -14,250	Y -14,25	Z 0,375	I 0	J -14,250			
N 80	G 00	G 40	X 14,25	Y -0,75					
N 90	G 90	Z 2							

Zerspanzeit t_h: Machining time t_h :	4,2 sec.
--	-----------------

¹⁾ Der über die Zahnschneidkante des Gewindeteils gemessene Fräserradius ist um den Betrag der Fräserradiuskorrektur zu reduzieren. Hiermit wird eine Zustellung auf Mitte der „6H/ISO2-Muttertoleranz“ erreicht. Die Fräserradiuskorrektur hängt aber auch von der radialen Verdrängung des Werkzeuges ab (Festigkeit des zu fräsenden Materials und Auskräglänge).

²⁾ Der zu programmierende Fräserradius ist üblicherweise im Werkzeugspeicher enthalten.

³⁾ Bei Steuerungen, welche die Berechnung des Mittelpunktvorschubs nicht selbstständig durchführen, müssen die Vorschubwerte in Klammern verwendet werden.

¹⁾ The cutter radius measured over the tooth crests of the threaded part must be reduced by the amount of the cutter radius compensation. This is necessary to achieve a depth of cut to the middle of the 6H/ISO2 nut tolerance. Please note, however, that this also depends on the radial deflection of the tool (tensile strength of the material, projection length of the tool).

²⁾ The cutter radius to be programmed is normally included in the tool memory.

³⁾ If your control does not calculate the centre point feed automatically please use the feed values printed in brackets.

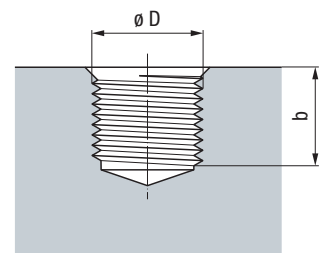
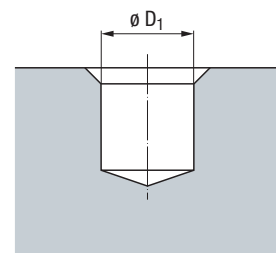
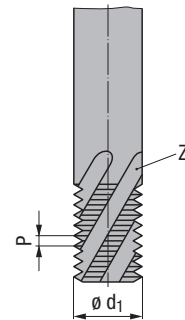

3.8 Programmierbeispiele (DIN)

Werkzeug: GF-KEG

3.8 Programming examples (DIN)

Tool: GF-KEG

Gewinde-Abmessung: Thread dimension:	NPT 1/2 - 14
Gewinde-Außendurchmesser D: Thread major diameter D:	21,092 mm
Kegelverhältnis: Taper ratio:	1 : 16
Steigung: Pitch:	1,814 mm
Kernlochdurchmesser D₃: Drilled hole diameter D ₃ :	17,850 mm
Nutzbare Tiefe t₄: Usable depth t ₄ :	15,384 mm
Werkstoff: Material:	GAISI9
Werkzeug-Abmessungen: Tool dimensions:	ø 14,25 x 19,01 x 80 mm
Schneidstoff: Cutting material:	VHM
Beschichtung: Coating:	TICN
Artikel-Nr.: Article no.:	GF173136.9678
Zähnezahl Z: No. of teeth Z:	4
Fräserdurchmesser d₁: Cutter diameter d ₁ :	14,250 mm
zu programmierender Fräserradius: Cutter radius to be programmed:	7,080 mm
Schnittgeschwindigkeit v_c: Cutting speed v _c :	250 m/min
Vorschub pro Zahn (Fräsen) f_z: Feed per tooth (milling) f _z :	0,120 mm
Drehzahl n: Speed n:	S = 5584 min ⁻¹
Vorschubgeschwindigkeit (Kontur) v_f: Feed speed (contour) v _f :	F = 2681 mm/min
Vorschubgeschwindigkeit (Mittelpunktsbahn) v_{fM}: Feed speed (centre point) v _{fM} :	F = 870 mm/min

(gemessen am Frästeil)
(measured on the cutting part)

$$n = \frac{v_c \cdot 1000}{d_1 \cdot \pi}$$

$$v_f = f_z \cdot Z \cdot n$$

$$v_{fM} = \frac{v_f \cdot (D - d_1)}{D}$$

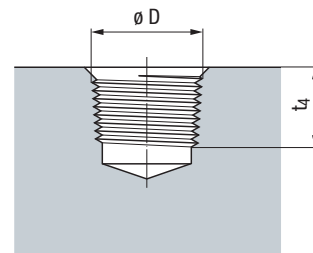
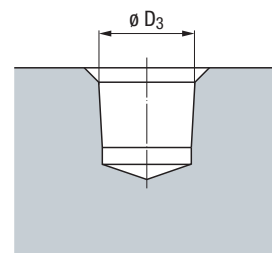
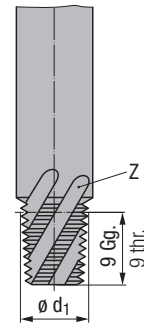

CNC-Innengewindefräsen (im Gleichlauf, an der Kontur, inkremental, nach DIN 66025)

CNC internal thread milling (climb milling, on the contour, incremental, acc. DIN 66025)

N 10	G 54	G 90	G 00	X...	Y...	Z 2	S 5584	T 01	M 03
N 20	G 91	G 00	Z -17,384						
N 30	G 01	G 41	Y -8,925	F 2681 (Kontur · Contour)			[F 870] ¹⁾ (Mittelpunkt · Centre point)		
N 40	G 03	X 0,000	Y 19,471	Z 0,907	I 0,000	J 9,736			
N 50	G 03	X -10,560	Y -10,546	Z 0,454	I -0,007	J -10,553			
N 60	G 03	X 10,560	Y -10,574	Z 0,454	I 10,567	J -0,007			
N 70	G 03	X 10,589	Y 10,574	Z 0,454	I 0,007	J 10,581			
N 80	G 03	X -10,589	Y 10,603	Z 0,454	I -10,596	J 0,007			
N 90	G 03	X 0,000	Y -19,528	Z 0,907	I 0,000	J -9,764			
N 100	G 01	G 40	Y 8,925						
N 110	G 90								
N 120	Z 2								

Zerspanzeit t_n: 2,9 sec.
Machining time t_n:

Das erste gefräste Gewinde ist unbedingt zu lehren, um eine eventuell erforderliche Werkzeugradius- oder Tiefenkorrektur vorzunehmen, welche sich aus dem planseitigen Abstand der Lehdorn-Messstufen zum Werkstück ergibt.

- Variable Werte zur Beeinflussung des gefrästen Gewindedurchmessers sind:**
1. Der zu programmierende Fräserradius im Werkzeugspeicher
 2. Die Eintauchtiefe (Gewindetiefe) Z- im Satz N 20

Radiuskorrektur = fehlende Einschraubtiefe x Kegelverhältnis (1 : 16) : 2

Merke: Ein kleinerer Werkzeugradius bewirkt ein tieferes Einschrauben!

¹⁾ Bei Steuerungen, welche die Berechnung des Mittelpunktvorschubs nicht selbstständig durchführen, müssen die Vorschubwerte in Klammern verwendet werden.

Please note that it is essential to gauge the first finished thread! This will make it possible to introduce a tool radius or depth compensation which may be necessary. Compensation is made by adjusting the distance of the measuring steps on the plane side of the plug gauge from the workpiece.

Variables for influencing the thread diameter on the workpiece:

1. The cutter radius to be programmed in the tool memory
2. The plunge depth (thread depth Z- in block N 20)

Radius compensation = lacking screw-in depth x taper ratio (1 : 16) : 2

Please note: A smaller tool radius will create an increased screw-in depth!

¹⁾ If your control does not calculate the centre point feed automatically please use the feed values printed in brackets.

Product Finder

v_c / f_z

M

MF

UNC
UN, UNS

UNF
UNEF

G, Rp

NPT, NPTF
Rc, W

BSW, BSF

Pg

EG (STI)
SELF-LOCK

Tr

Zubehör
Accessories

Tech. Info

BGF

ZBGF

GSF

GF

GF-KEG

ZGF

ZIRK-GF

Gigant

MoSys



Product Finder

v_c / f_z

3.8 Programmierbeispiele (DIN)

Werkzeug: GF (Außengewinde)

3.8 Programming examples (DIN)

Tool: GF (external thread)

M
MF
UNC
UN, UNS
UNF
UNEF
G, Rp
NPT, NPTF
Rc, W
BSW, BSF
Pg
EG (STI)
SELF-LOCK
Tr
Zubehör
Accessories

Gewinde-Abmessung: Thread dimension:	M20 x 1,5 - 6g
Gewinde-Nenndurchmesser D: Nominal thread diameter D:	20,000 mm
Gewindesteigung P: Thread pitch P:	1,500 mm
Gewindelänge b: Thread length b:	20,000 mm
Werkstoff: Material:	GAISI9
Werkzeug-Abmessungen: Tool dimensions:	∅ 20 x 32 x 105 mm
Schneidstoff: Cutting material:	VHM
Beschichtung: Coating:	TICN
Artikel-Nr.: Article no.:	GF161156.9514
Zähnezahl Z: No. of teeth Z:	5
Fräserdurchmesser d₁: Cutter diameter d ₁ :	20,000 mm
Fräserradiuskorrektur k¹⁾: Cutter radius compensation k ¹⁾ :	0,075 mm
zu programmierender Fräserradius²⁾: Cutter radius to be programmed ²⁾ :	9,925 mm
Schnittgeschwindigkeit v_c: Cutting speed v _c :	250 m/min
Vorschub pro Zahn (Fräsen) f_z: Feed per tooth (milling) f _z :	0,150 mm
Drehzahl n: Speed n:	S = 3981 min ⁻¹
Vorschubgeschwindigkeit (Kontur) v_f: Feed speed (contour) v _f :	F = 2986 mm/min
Vorschubgeschwindigkeit (Mittelpunktsbahn) v_{fM}: Feed speed (centre point) v _{fM} :	F = 5971 mm/min

(gemessen am Frästeil)
(measured on the cutting part)

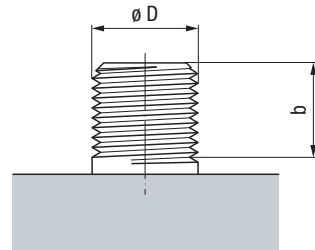
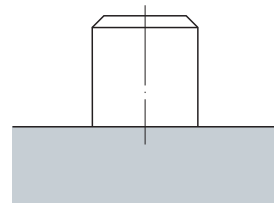
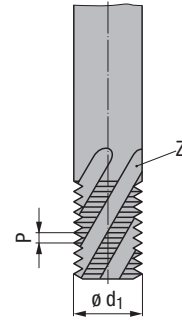

$$n = \frac{v_c \cdot 1000}{d_1 \cdot \pi}$$

$$v_f = f_z \cdot Z \cdot n$$

$$v_{fM} = \frac{v_f \cdot (D + d_1)}{D}$$

Tech. Info

BGF
ZBGF
GSF
GF
GF-KEG
ZGF
ZIRK-GF
Gigant
MoSys

CNC-Außengewindefräsen (im Gleichlauf, an der Kontur, inkremental, nach DIN 66025)

CNC external thread milling (climb milling, on the contour, incremental, acc. DIN 66025)

N 10	G 54	G 90	G 00	X ...	Y ...	Z 2	S 3981	T 01 ²⁾	M,03
N 20	G 91	G 00	X -10,000	Y 20,000					
N 30	G 00	Z -19,750							
N 40	G 41	G 01	Y -10,975		F 2986 (Kontur · Contour)		[F 5971] ³⁾	(Mittelpunkt · Centre point)	
N 50			X 10,000	Z -0,300					
N 60	G 02	X 0	Y 0	Z -1,500	I 0	J -9,025			
N 70	G 01	X 10,000	Y 0	Z -0,300					
N 80	G 40	G 00	Y 10,975						
N 90	G 90	Z 2							

Zerspanzeit t_h:
Machining time t_h: **1,5 sec.**

¹⁾ Der über die Zahnspitze des Gewindeteils gemessene Fräserradius ist um den Betrag der Fräserradiuskorrektur zu reduzieren. Hiermit wird eine Zustellung auf Mitte der „6g/ISO2-Bolzentoleranz“ erreicht. Die Fräserradiuskorrektur hängt aber auch von der radialen Verdrängung des Werkzeuges ab (Festigkeit des zu fräsenden Materials und Auskräglänge).

²⁾ Der zu programmierende Fräserradius ist üblicherweise im Werkzeugspeicher enthalten.

³⁾ Bei Steuerungen, welche die Berechnung des Mittelpunktsvorschubs nicht selbstständig durchführen, müssen die Vorschubwerte in Klammern verwendet werden.

¹⁾ The cutter radius measured over the tooth crests of the threaded part must be reduced by the amount of the cutter radius compensation. This is necessary to achieve a depth of cut to the middle of the 6g/ISO2 bolt tolerance. Please note, however, that this also depends on the radial deflection of the tool (tensile strength of the material, projection length of the tool).

²⁾ The cutter radius to be programmed is normally included in the tool memory.

³⁾ If your control does not calculate the centre point feed automatically please use the feed values printed in brackets.

3.8 Programmierbeispiele (DIN)

Werkzeug: ZIRK-GF

3.8 Programming examples (DIN)

Tool: ZIRK-GF

Gewinde-Abmessung: Thread dimension:	M30 x 1,5 - 6H
Gewinde-Nenndurchmesser D: Nominal thread diameter D:	30,000 mm
Gewindesteigung P: Thread pitch P:	1,500 mm
Kernlochdurchmesser D₁: Drilled hole diameter D ₁ :	28,500 mm
Gewindetiefe b: Thread depth b:	25,000 mm
Werkstoff: Material:	GAISI9
Werkzeug-Abmessungen: Tool dimensions:	∅ 16 x 125 mm
Schneidstoff: Cutting material:	HM
Beschichtung: Coating:	TIN
Artikel-Nr.: Article no.:	GZ301310 GF603115.9514
Zähnezahl Z: No. of teeth Z:	1
Fräserdurchmesser d₁: Cutter diameter d ₁ :	16,000 mm
Schneidenlänge l₂: Cutting length l ₂ :	15,000 mm
Fräserradiuskorrektur k¹⁾: Cutter radius compensation k ¹⁾ :	0,075 mm
zu programmierender Fräserradius²⁾: Cutter radius to be programmed ²⁾ :	7,925 mm
Schnittgeschwindigkeit v_c: Cutting speed v _c :	250 m/min
Vorschub pro Zahn (Fräsen) f_z: Feed per tooth (milling) f _z :	0,150 mm
Drehzahl n: Speed n:	S = 4976 min ⁻¹
Vorschubgeschwindigkeit (Kontur) v_f: Feed speed (contour) v _f :	F = 746 mm/min
Vorschubgeschwindigkeit (Mittelpunktsbahn) v_{fM}: Feed speed (centre point) v _{fM} :	F = 348 mm/min

(gemessen am Frästeil)
(measured on the cutting part)

$$(0,05 \cdot P)$$

$$(0,5 \cdot d_1 - k)$$

$$n = \frac{v_c \cdot 1000}{d_1 \cdot \pi}$$

$$v_f = f_z \cdot Z \cdot n$$

$$v_{fM} = \frac{v_f \cdot (D - d_1)}{D}$$

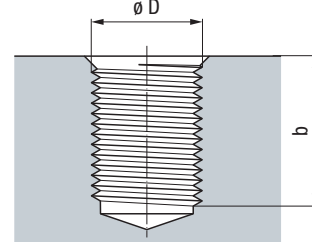
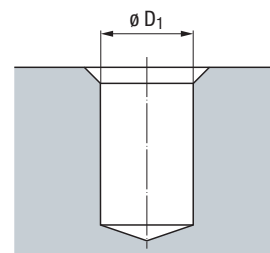
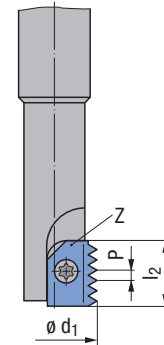

CNC-Innengewindefräsen (im Gleichlauf, an der Kontur, inkremental, nach DIN 66025)

CNC internal thread milling (climb milling, on the contour, incremental, acc. DIN 66025)

N 10	G 54	G 90	G 00	X ...	Y ...	Z 2	S 4976	T01 ²⁾	M03
N 20	G 91	G 00	Z-27,000						
N 30	G 01	Y 0,750				F 746 (Kontur · Contour)	[F 348] ³⁾	(Mittelpunkt · Centre point)	
N 40	G 41	G 01	X 14,250						
N 50	G 03	X -14,250	Y 14,250	Z 0,375	I -14,250	J 0			
N 60	G 03	X 0	Y 0	Z 1,500	I 0	J -15,000			
N 70	G 03	X -14,250	Y-14,250	Z 0,375	I 0	J -14,250			
N 80	G 00	G 40	X 14,250	Y -0,750					
N 90	G 00	Z 11,250							
... ⁴⁾									
N 170	G90								

Zerspanzeit t_h: 22,3 sec.
Machining time t_h:

¹⁾ Der über die Zahnspitze des Gewindeteils gemessene Fräserradius ist um den Betrag der Fräserradiuskorrektur zu reduzieren. Hiermit wird eine Zustellung auf Mitte der „6H/ISO2-Muttertoleranz“ erreicht. Die Fräserradiuskorrektur hängt aber auch von der radialen Verdrängung des Werkzeuges ab (Festigkeit des zu fräsenden Materials und Auskraglänge).

²⁾ Der zu programmierende Fräserradius ist üblicherweise im Werkzeugspeicher enthalten.

³⁾ Bei Steuerungen, welche die Berechnung des Mittelpunktvorschubs nicht selbstständig durchführen, müssen die Vorschubwerte in Klammern verwendet werden.

⁴⁾ Die Satznummern N 30 bis N 90 müssen entsprechend der Anzahl der Wiederholungen erneut aufgerufen werden.

¹⁾ The cutter radius measured over the tooth crests of the threaded part must be reduced by the amount of the cutter radius compensation. This is necessary to achieve a depth of cut to the middle of the 6H/ISO2 nut tolerance. Please note, however, that this also depends on the radial deflection of the tool (tensile strength of the material, projection length of the tool).

²⁾ The cutter radius to be programmed is normally included in the tool memory.

³⁾ If your control does not calculate the centre point feed automatically please use the feed values printed in brackets.

⁴⁾ The block numbers N 30 to N 90 must be called up anew according to the number of repetitions.

Product Finder

v_c / f_z

M

MF

UNC
UN, UNS

UNF
UNEF

G, Rp

NPT, NPTF
Rc, W

BSW, BSF

Pg

EG (STI)
SELF-LOCK

Tr

Zubehör
Accessories

Tech. Info

BGF

ZBGF

GSF

GF

GF-KEG

ZGF

ZIRK-GF

Gigant

MoSys



Product Finder

3.8 Programmierbeispiele (DIN)

3.8 Programming examples (DIN)

v_c / f_z

Werkzeug: Gigant-ic, Gr.12

Tool: Gigant-ic, Size 12

M	Gewinde-Abmessung: Thread dimension:	M42 - 6H
MF	Gewinde-Nenndurchmesser D: Nominal thread diameter D:	42,000 mm
UNC UN, UNS	Gewindesteigung P: Thread pitch P:	4,500 mm
UNF UNEF	Kernlochdurchmesser D₁: Drilled hole diameter D ₁ :	37,500 mm
G, Rp	Gewindetiefe b³⁾: Thread depth b ³⁾ :	63,000 mm
NPT, NPTF Rc, W	Werkstoff: Material:	1.1730
BSW, BSF	Werkzeug-Abmessungen: Tool dimensions:	∅ 32,85 x 153 mm
Pg	Schneidstoff: Cutting material:	VHM
EG (STI) SELF-LOCK	Beschichtung: Coating:	TIN
Tr	Artikel-Nr.: Article no.:	GZ341032 GF643205.9517
Zubehör Accessories	Zähnezahl Z: No. of teeth Z:	3
Tech. Info	Fräserdurchmesser d₁: Cutter diameter d ₁ :	32,850 mm (gemessen am Frästeil) (measured on the cutting part)
BGF	Fräserradiuskorrektur k¹⁾: Cutter radius compensation k ¹⁾ :	0,174 mm (je nach Einsatzfall) (acc. work case)
ZBGF	zu programmierender Fräserradius²⁾: Cutter radius to be programmed ²⁾ :	16,251 mm (0,5 · d ₁ - k)
GSF	Schnittgeschwindigkeit v_c: Cutting speed v _c :	250 m/min
GF	Vorschub pro Zahn (Fräsen) f_z: Feed per tooth (milling) f _z :	0,200 mm
GF-KEG	Drehzahl n: Speed n:	S = 2424 min ⁻¹ $n = \frac{v_c \cdot 1000}{d_1 \cdot \pi}$
ZGF	Vorschubgeschwindigkeit (Kontur) v_f: Feed speed (contour) v _f :	F = 1454 mm/min $v_f = f_z \cdot Z \cdot n$
ZIRK-GF	Vorschubgeschwindigkeit (Mittelpunktsbahn) v_{fM}: Feed speed (centre point) v _{fM} :	F = 317 mm/min $v_{fM} = \frac{v_f \cdot (D - d_1)}{D}$

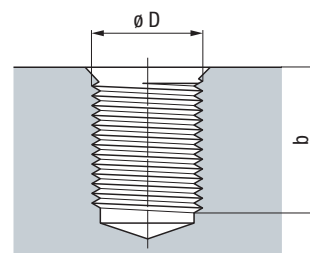
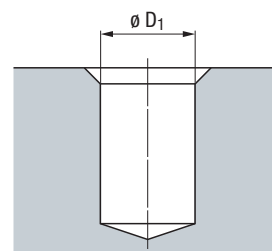
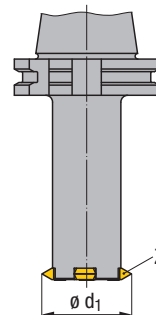

CNC-Innengewindefräsen (im Gegenlauf, an der Kontur, inkremental, nach DIN 66025)

CNC internal thread milling (conventional milling, on the contour, incremental, acc. DIN 66025)

N 10	G 54	G 90	G 00	X...	Y...	Z 0,000	S 2424	T01 ²⁾	M03
N 20	G 91								
N 30	G 42	G 01		X 0	Y -21	F 1454 (Kontur - Contour)		[F 317] ⁴⁾	(Mittelpunkt - Centre point)
N 40	G 02			X 0	Y 0	Z -4,500	I 0	J 21,000	
... ⁵⁾									
N 50	G 40	G 01		X 0	Y 21				
N 70	G 90	G 00		Z 4,5					

Zerspanzeit t_h: Machining time t _h :	72,6 sec. (1,2 min.)
Anzahl der Gewindegänge⁵⁾: Number of threads ⁵⁾ :	13

¹⁾ Der zu programmierende Fräserradius ist je nach Einsatzfall zu korrigieren, bis das Gewinde die gewünschte Muttertoleranz, z.B. 6H/ISO2 erreicht. Die Fräserradiuskorrektur hängt aber auch von der radialen Verdrängung des Werkzeugs ab (Festigkeit des zu fräsenden Materials und Auskraglänge).

²⁾ Der zu programmierende Fräserradius ist üblicherweise im Werkzeugspeicher enthalten.

³⁾ Die eingegebene Gewindetiefe b muss durch die Steigung P teilbar sein.

⁴⁾ Bei Steuerungen, welche die Berechnung des Mittelpunktsvorschubs nicht selbstständig durchführen, müssen die Vorschubwerte in Klammern verwendet werden.

⁵⁾ Satz N 40 muss mit Anzahl der Gewindegänge wiederholt werden.

¹⁾ The cutter radius to be programmed must be corrected, depending on the work case, until the thread achieves the required nut tolerance, e.g. 6H/ISO2. Please note, however, that this also depends on the radial deflection of the tool (tensile strength of the material, projection length of the tool).

²⁾ The cutter radius to be programmed is normally included in the tool memory.

³⁾ The thread depth b as entered must be divisible by the pitch P.

⁴⁾ If your control does not calculate the centre point feed automatically please use the feed values printed in brackets.

⁵⁾ Block N 40 must be repeated with the number of threads.

3.9 Technischer Fragebogen: Gewindefräsen

Firma:
 Ansprechpartner:
 Telefon:
 Fax:
 E-Mail:

Abmessung:
 Ausführung:
 Artikel-Nr.:
 Projekt:

Werkstückbezeichnung:
 Werkstückwerkstoff:

Ident-Nr.:
 Festigkeit / Härte:

Einsatzbedingungen:

Maschinentyp:
 Steuerung:
 horizontal vertikal
 Werkzeugaufnahme:
 Schnittgeschwindigkeit v_c : m/min
 Drehzahl n: min^{-1}
 Standwert: (Anzahl der Gewinde)

Spindelaufnahme:
 Kernlochform / Bolzenform:
 Kühlschmierstoff:
 Druck: IKZ
 Vorschubwerte: f_z : mm
 f_s : mm
 f_b : mm

Kunde fräst bereits Gewinde:
 Abmessung:
 Hersteller:

Ergebnis / besondere Hinweise:

Zu erledigen:

Skizze:

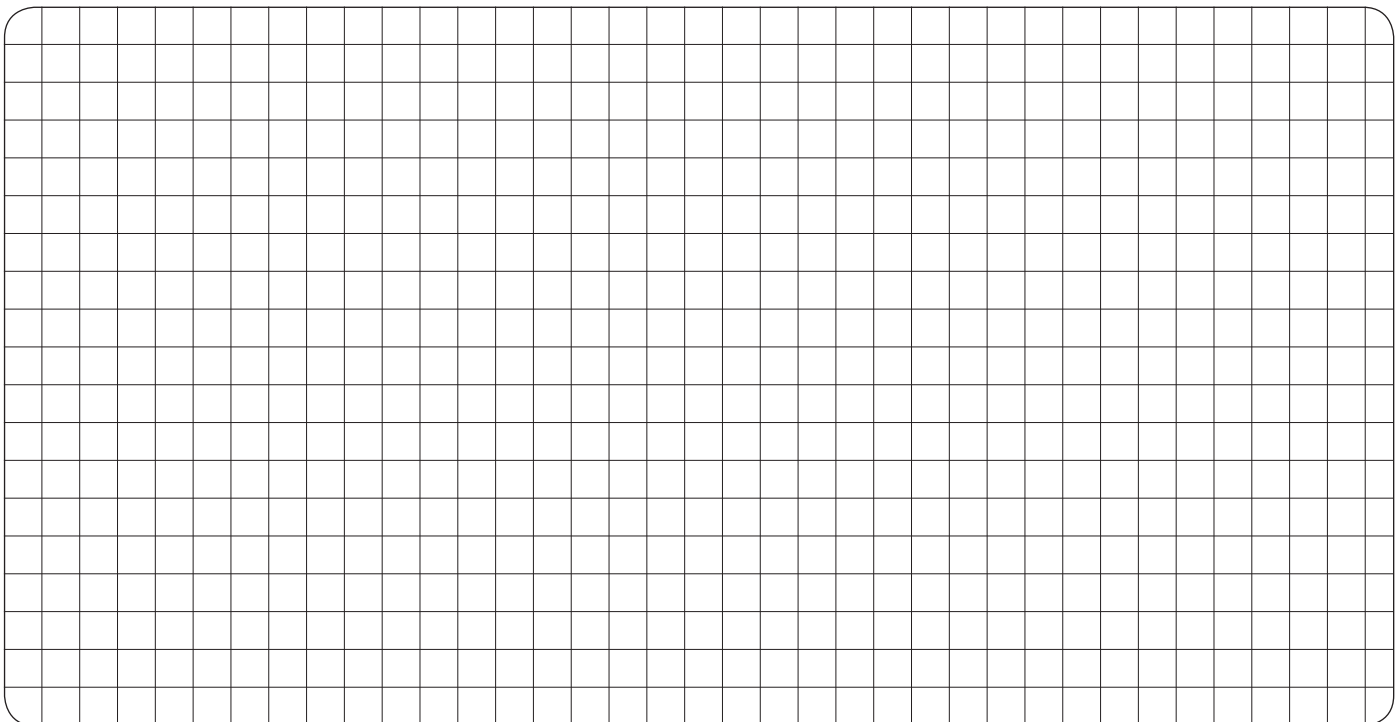

Aufgenommen von:

Datum / Unterschrift:

Product Finder

v_c / f_z

M

MF

UNC
UN, UNS

UNF
UNEF

G, Rp

NPT, NPTF
Rc, W

BSW, BSF

Pg

EG (STI)
SELF-LOCK

Tr

Zubehör
Accessories

Tech. Info

BGF

ZBGF

GSF

GF

GF-KEG

ZGF

ZIRK-GF

Gigant

MoSys



- Product Finder
- v_c / f_z
- M
- MF
- UNC
UN, UNS
- UNF
UNEF
- G, Rp
- NPT, NPTF
Rc, W
- BSW, BSF
- Pg
- EG (STI)
SELF-LOCK
- Tr
- Zubehör
Accessories
- Tech. Info**
- BGF
- ZBGF
- GSF
- GF
- GF-KEG
- ZGF
- ZIRK-GF
- Gigant
- MoSys

3.9 Technical questionnaire: Thread milling

Company: Size:

Contact: Design:

Phone: Article no.:

Fax: Project:

E-mail:

Workpiece description: Ident no.:

Workpiece material: Tensile strength / hardness:

Work conditions:

Machine type: Spindle adaptation:

Control: Hole type / bolt type:

horizontal vertical Coolant-lubricant:

Tool holder: Pressure: Internal coolant supply

Cutting speed v_c : m/min Feed values: f_z : mm

Speed n: rpm f_s : mm

Tool life: (no. of threads) f_b : mm

Customer is already milling threads: Result / special information:

Size:

Manufacturer:

Agenda:

Sketch:

Filled in by: Date / signature:

