

Portaherramientas de fresado regulable en ángulo - Placa TCMT

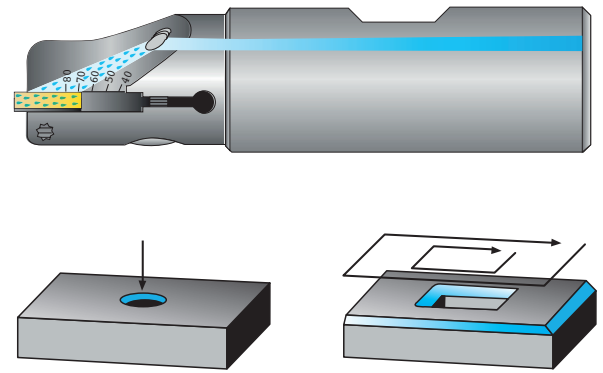

Referencia	dh6	L	Y°	D-Min ø	D-Max ø	Ref. Int	Tornillo Placa	Tornillo Porta	Para Placa
NPDF-FD16-L100-TC11	16	100	10°-80°	ø5	ø27	NO	TDA-099	TDA-100	TCMT1102..
NPDF-FD20-L100-TC11	20	100	10°-80°	ø5	ø27	SI	TDA-099	TDA-100	TCMT1102..
NPDF-FD20-L150-TC11	20	150	10°-80°	ø5	ø27	NO	TDA-099	TDA-100	TCMT1102..
NPDF-FD20-L100-TC16	20	100	10°-80°	ø5	ø34	NO	TDA-097	TDA-101	TCMT16T3..
NPDF-FD25-L100-TC16	25	100	10°-80°	ø5	ø34	SI	TDA-097	TDA-101	TCMT16T3..
NPDF-FD25-L150-TC16	25	150	10°-80°	ø5	ø34	NO	TDA-097	TDA-101	TCMT16T3..
NPDF-FD25-L200-TC16	25	200	10°-80°	ø5	ø34	NO	TDA-097	TDA-101	TCMT16T3..

Portaherramientas de fresado regulable en ángulo - Placa SCMT

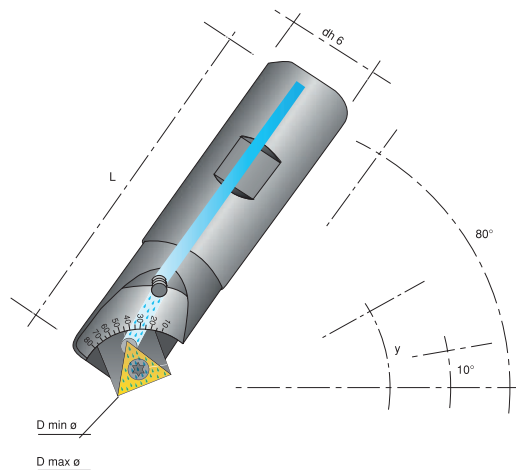
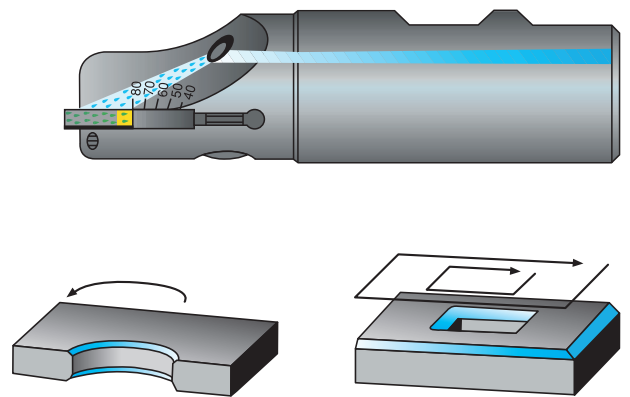
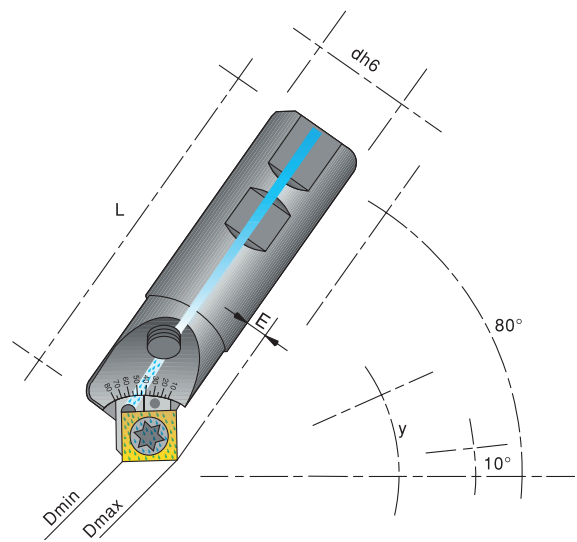

Referencia	dh6	L	Y°	D-Min	D-Max	E	Ref. Int	Tornillo Placa	Tornillo Porta	Para Placa
NPDF-FD20-L100-SC12	20	100	-	-	-	-	NO	TDA-100	TDA-101	SCMT1204..
NPDF-FD25-L100-SC12	25	100	-	-	-	-	SI	TDA-100	TDA-101	SCMT1204..
NPDF-FD25-L150-SC12	25	150	-	-	-	-	NO	TDA-100	TDA-101	SCMT1204..
NPDF-FD25-L200-SC12	25	200	-	-	-	-	NO	TDA-100	TDA-101	SCMT1204..
DATOS DE ÁNGULOS			10°	7.5	30	2.7				
			20°	10	32	3.6				
			30°	13	32.5	4.3				
			40°	16.5	33.5	4.5				
			50°	19	33.5	4.6				
			60	22	33.5	4.3				
			70	24.5	32.5	3.8				
			80	27	31	3				

Portaherramientas de fresado regulable para radio - Placa NXDCW1503M

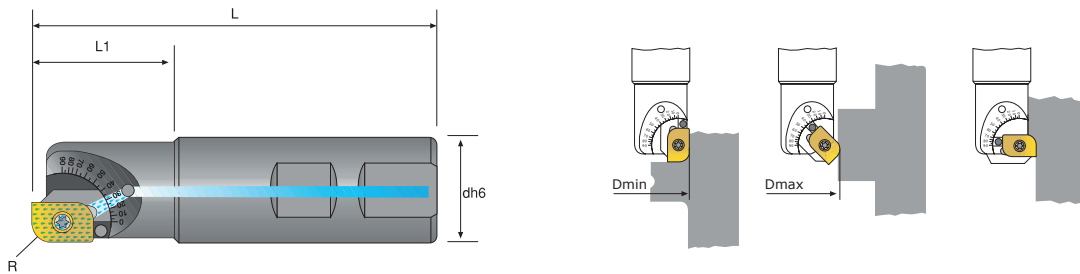

Referencia	dh6	L	L1	D-Min ø	D-Max ø	Ref. Int	Soporte Placa	Tornillo Porta	Para Placa
NPDF-FD20-L100-NXD15M	20	100	37	26.5	34	NO	PB-043	TDA-102	NXDCW1503M
NPDF-FD25-L100-NXD15M	25	100	37	26.5	34	SI	PB-043	TDA-102	NXDCW1503M
NPDF-FD25-L150-NXD15M	25	150	37	26.5	34	NO	PB-043	TDA-102	NXDCW1503M
NPDF-FD25-L200-NXD15M	25	200	37	26.5	34	NO	PB-043	TDA-102	NXDCW1503M

Portaherramientas de fresado regulable para radio - Placa NXDCW1503F

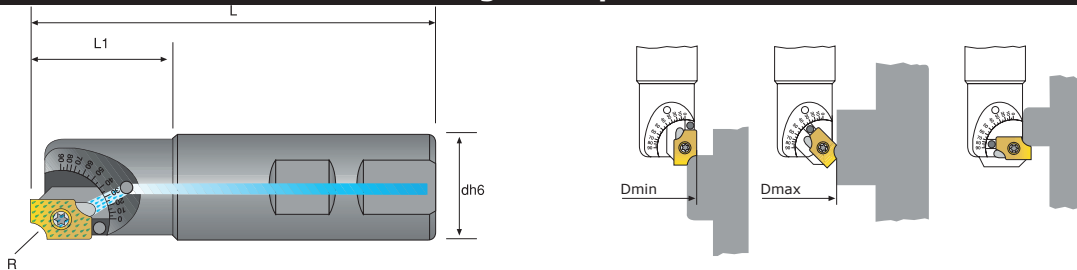

Referencia	dh6	L	L1	D-Min ø	D-Max ø	Ref. Int	Soporte Placa	Tornillo Porta	Para Placa
NPDF-FD20-L100-NXD15F	20	100	37	26.5	33	NO	PB-044	TDA-102	NXDCW1503F
NPDF-FD25-L100-NXD15F	25	100	37	26.5	33	SI	PB-044	TDA-102	NXDCW1503F
NPDF-FD25-L150-NXD15F	25	150	37	26.5	33	NO	PB-044	TDA-102	NXDCW1503F
NPDF-FD25-L200-NXD15F	25	200	37	26.5	33	NO	PB-044	TDA-102	NXDCW1503F

Portaherramientas de fresado para radio - Placa NXDCW1503M y NXPCW2004M

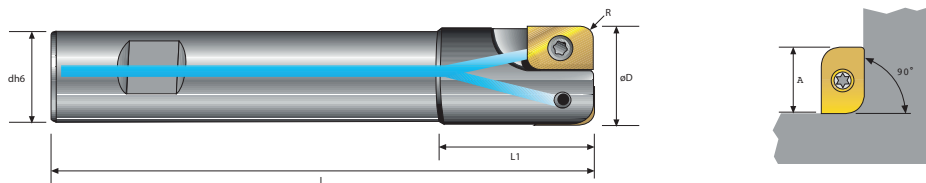

Referencia	øD	dh6	L	L1	A	Z	Tornillo Porta	Para Placa
NPDF-FD17-NX15	17	16	120	30	15	1	TDA-102	NXDCW1503M
NPDF-FD22-NX20	22	20	120	35	15	2	TDA-102	NXPCW2004M
NPDF-FD32-NX20	32	25	120	40	20	2	TDA-100	NXPCW2004M

Portaherramientas de fresado para radio - Placa NXDCW1503F y NXPCW2004F

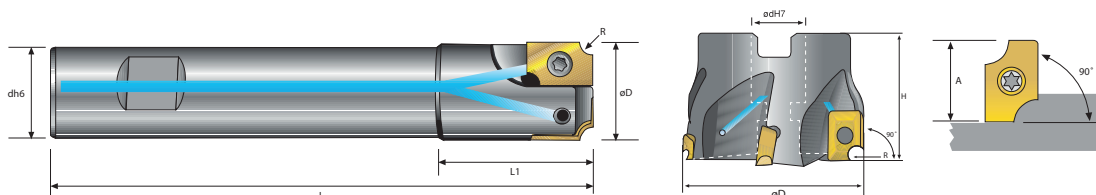

Referencia	øD	dh6	øD7	L	L1	H	A	Z	Tornillo Porta	Para Placa
NPDF-FD17-NX15	17	16	-	120	30	-	15	1	TDA-102	NXDCW1503F
NPDF-FD22-NX15	22	20	-	120	35	-	15	2	TDA-102	NXDCW1503F
NPDF-FD32-NX15	32	25	-	120	40	-	20	2	TDA-102	NXDCW1503F
NPDF-FD40-NX20	40	-	16	-	-	40	15	4	TDA-100	NXPCW2004F
NPDF-FD50-NX20	50	-	22	-	-	50	20	4	TDA-100	NXPCW2004F

Portaherramientas de fresado 90° - AD..1505

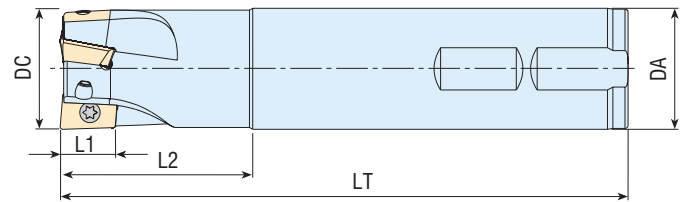

REFERENCIA	DC	Z	DA	LT	L2	L1	INSERTO	TORNILLO	LLAVE
NPDF90-AD1505-D25-W25-L150-2	25	2	25	150	50	14.3			
NPDF90-AD1505-D30-W25-L150-3	30	3	25	150	40	14.3	AD..1505..	TDA-064	LLT-15
NPDF90-AD1505-D32-W32-L150-3	32	3	25	150	50	14.3			

Portaherramientas de fresado 90° - ADMX0702.. / ADMX11T30..

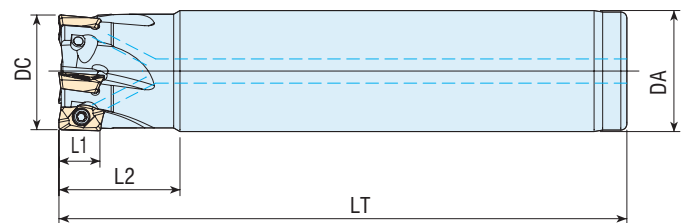

REFERENCIA	DC	Z	DA	LT	L2	L1	INSERTO	TORNILLO	LLAVE
NPDF90-AD07-D10-C08-L90-2R	10	2	8	90	16	6	ADMX0702..	TDA-004	LLT-6
NPDF90-AD07-D10-C10-L80-2R	10	2	10	80	16	6		TDA-003	
NPDF90-AD07-D12-C10-L80-3R	12	3	10	80	18	6		TDA-004	
NPDF90-AD07-D12-C12-L90-3R	12	3	12	90	18	6		TDA-005	
NPDF90-AD07-D16-C16-L110-4R	16	4	16	110	19	6		TDA-006	
NPDF90-AD07-D20-C20-L125-5R	20	5	20	125	20	6			
NPDF90-AD07-D25-C25-L140-6R	25	6	25	140	24	6			
NPDF90-AD11-D16-C16-L135-2R	16	2	16	135	24	9	ADMX11T30..	TDA-013	LLT-8
NPDF90-AD11-D18-C16-L135-2R	18	2	16	135	15	9			
NPDF90-AD11-D18-C16-L160-2R	18	2	16	160	15	9			
NPDF90-AD11-D20-C20-L150-2R	20	2	20	150	50	9			
NPDF90-AD11-D20-C20-L150-3R	20	3	20	150	50	9			
NPDF90-AD11-D22-C20-L150-3R	22	3	20	150	15	9		TDA-014	LLT-8
NPDF90-AD11-D22-C20-L200-3R	22	3	20	200	15	9			
NPDF90-AD11-D25-C25-L170-3R	25	3	25	170	50	9			
NPDF90-AD11-D25-C25-L170-4R	25	4	25	170	50	9			
NPDF90-AD11-D28-C25-L165-4R	28	4	25	165	17	9			
NPDF90-AD11-D28-C25-L200-4R	28	4	25	200	17	9			
NPDF90-AD11-D30-C25-L165-4R	30	4	25	165	19	9			
NPDF90-AD11-D30-C25-L200-4R	30	4	25	200	19	9			
NPDF90-AD11-D32-C32-L195-5R	32	5	32	195	50	9			

Portaherramientas de fresado 90° - ADMT08 / ADMT10 ADMT / ADMT

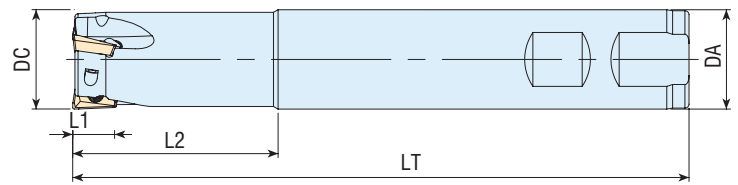

REFERENCIA	DC	Z	DA	LT	L2	L1	INSERTO	TORNILLO	LLAVE
NPDF90-ADMT08-D16-W16-L150-2	16	2	16	150	30	8			
NPDF90-ADMT08-D17-W16-L150-2	17	2	16	150	30	8	ADMT0803..	TDA-013	LLT-8
NPDF90-ADMT08-D17-W16-L200-2	17	2	16	200	30	8			
NPDF90-ADMT08-D20-W20-L150-3	20	3	20	150	30	8			
NPDF90-ADMT08-D21-W20-L200-3	21	3	20	200	30	8			
NPDF90-AD10T3-D16-W16-L100-2R	16	2	16	100	30	10	ADMT10T3..	TDA-014	LLT-8
NPDF90-AD10T3-D16-W16-L150-2	16	2	16	150	40	10			
NPDF90-AD10T3-D16-C16-L200-2	16	2	16	200	50	10			
NPDF90-AD10T3-D17-W16-L150-2	17	2	16	150	30	10			
NPDF90-AD10T3-D17-W16-L200-2	17	2	16	200	30	10			
NPDF90-AD10T3-D20-W20-L30-3	20	3	20	70	30	10			
NPDF90-AD10T3-D20-W20-L100-3R	20	3	20	100	30	10			
NPDF90-AD10T3-D20-W20-L150-3	20	3	20	150	40	10			
NPDF90-AD10T3-D20-C20-L150-3	20	3	20	150	40	10			
NPDF90-AD10T3-D20-C20-L200-3	20	3	20	200	50	10			
NPDF90-AD10T3-D25-W25-L100-3R	25	3	25	100	30	10			
NPDF90-AD10T3-D25-W25-L100-4R	25	4	25	100	30	10			
NPDF90-AD10T3-D25-W25-L150-3	25	3	25	150	50	10			
NPDF90-AD1204-D20-W20-L150-2	20	2	20	150	50	12	ADMT1204..	TDA-031	LLT-10
NPDF90-AD1204-DD21-C20-L150-2	21	2	20	150	30	12			
NPDF90-AD1204-D22-C20-L150-2	22	2	20	150	30	12			
NPDF90-AD1204-D25-W25-L150-3	25	3	25	150	50	12			
NPDF90-AD1204-D26-W25-L180-3	26	3	25	180	30	12			
NPDF90-AD1204-D32-W32-L150-4	32	4	32	150	50	12			
NPDF90-AD1606-D25-W25-L150-2	25	2	25	150	50	12	ADMT1606..	TDA-064	LLT-15
NPDF90-AD1606-D32-W32-L150-3	32	3	32	150	50	15			

Portaherramientas de fresado 90° - ANKX1207..

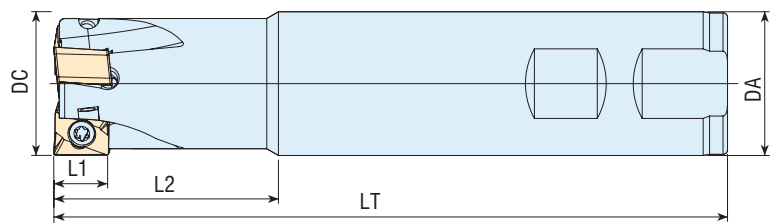

REFERENCIA	DC	zefp	dconLF	LH	LF	APMX	INSERTO	TORNILLO	LLAVE
NPDF-90-ANKX1207-D25-W25-L150-2	25	2	25	150	40	10	ANKX1207..	TDA-066	LLT-15
NPDF-90-ANKX1207-D32-W32-L150-3	32	3	32	150	50	10			
NPDF-90-ANKX1207-D40-W32-L150-4	40	4	32	150	40	10			

Portaherramientas de fresado 90° - ADMT1003 / ADKT1505

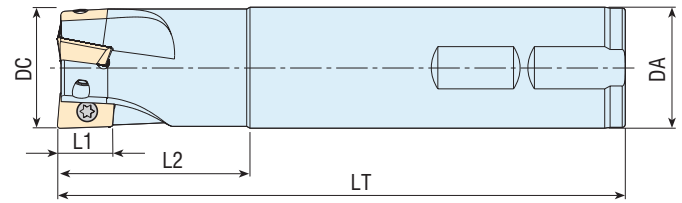

REFERENCIA	DC	Z	DA	LT	L2	L1	INSERTO	TORNILLO	LLAVE
NPDF90-AD1003-D16-C16-L150-2	16	2	16	150	30	8	ADMT1003..	TDA-013	LLT-8
NPDF90-AD1003-D17-C16-L150-2	17	2	16	150	25	8			
NPDF90-AD1003-D20-C20-L200-3	20	3	20	200	50	8		TDA-014	LLT-8
NPDF90-AD1003-D21-C20-L150-3	21	3	20	150	25	8			
NPDF90-AD1003-D21-C20-L200-3	21	3	20	200	25	8		TDA-006	LLT-8
NPDF90-AD1003-D25-C25-L200-3	25	3	25	200	50	8			
NPDF90-AD1003-D26-C25-L150-3	26	3	25	150	30	8			
NPDF90-AD1003-D26-C25-L200-3	26	3	25	200	30	8			
NPDF90-AD1505D-D25-W25-L150-2	25	2	25	150	50	14.3	ADKT1505..	TDA-066	
NPDF90-AD1505D-D32-W32-L150-3	32	3	32	150	50	14.3		TDA-066	

Portaherramientas de fresado 90° - ANGX1105

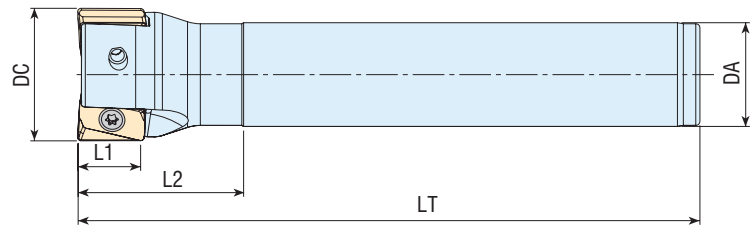

REFERENCIA	DC	Z	DA	LT	L2	L1	INSERTO	TORNILLO	LLAVE
NPDF90-AN11-D22-W20-L150-2	22	2	20	150	30	11	ANGX1105..	TDA-032	LLT-10
NPDF90-AN11-D25-W25-L150-2	25	2	25	150	40	11			
NPDF90-AN11-D25-C25-L200-2	25	2	25	200	40	11			
NPDF90-AN11-D26-W25-L150-2	26	2	25	150	40	11			
NPDF90-AN11-D28-W25-L150-2	28	2	25	150	25	11			
NPDF90-AN11-D32-W32-L150-3	32	3	32	150	50	11			
NPDF90-AN11-D32-C32-L200-3	32	3	32	200	50	11			
NPDF90-AN11-D40-W32-L150-4	40	4	32	150	40	11			

Portaherramientas de fresado 90° - AN.X1607..

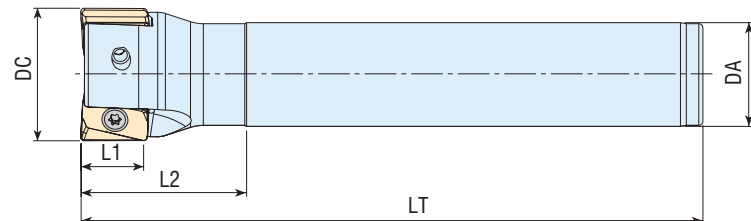

REFERENCIA	DC	Z	DA	LT	L2	L1	INSERTO	TORNILLO	LLAVE
NPDF-90-AN1607-D32-C25-L150-2	32	2	25	150	50	15	AN.X1607..	TDA-066	LLT-15
NPDF-90-AN1607-D40-C32-L150-3	40	3	32	150	50	15			

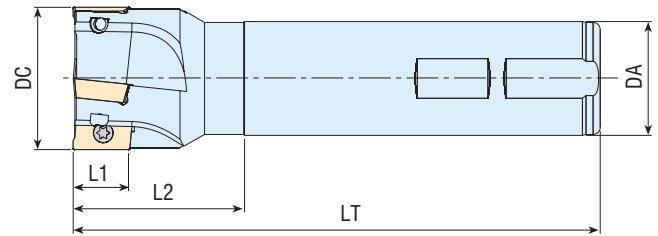
Portaherramientas de fresado 90° - APMT0602.. / APMT0903.. / APKT09T3..

REFERENCIA	DC	Z	DA	LT	L2	L1	INSERTO	TORNILLO	ALLAVE
NPDF90-AP06-D10-C10-L120-2	10	2	10	120	20	5.6	APMT0602..	TDA-002	LLT-6
NPDF90-AP06-D12-C12-L120-2	12	2	12	120	20	5.6	APMT0903..	TDA-013	LLT-8
NPDF90-AP0903-D12-C16-L080-1R	12	1	16	80	30	9			
NPDF90-AP0903-D16-C16-L090-2	16	2	16	90	30	9			
NPDF90-AP0903-D16-C16-L150-2	16	2	16	150	30	9			
NPDF90-AP0903-D17-C16-L150-2	17	2	16	150	30	9			
NPDF90-AP0903-D18-C16-L090-2R	18	2	16	90	30	9	APMT0903..	TDA-014	LLT-8
NPDF90-AP0903-D20-C20-L110-3	20	3	20	110	30	9			
NPDF90-AP0903-D20-C20-L150-2	20	2	20	150	30	9			
NPDF90-AP0903-D20-C20-L200-2	20	2	20	200	100	9			
NPDF90-AP0903-D21-C20-L150-2	21	2	20	150	30	9			
NPDF90-AP0903-D25-C25-L120-3	25	3	25	120	30	9			
NPDF90-AP0903-D25-C25-L150-3	25	3	25	150	30	9			
NPDF90-AP0903-D25-C25-L200-2	25	2	25	200	100	9			
NPDF90-AP09-D16-C16-L100-2R	16	2	16	100	30	8.8	APKT09T3..	TDA-013	LLT-8
NPDF90-AP09-D16-C15-L150-2	16	2	15	150	25	8.8			
NPDF90-AP09-D16-W16-L150-2R	16	2	16	150	25	8.8			
NPDF90-AP09-D16-C16-L200-2R	16	2	16	200	100	8.8			
NPDF90-AP09-D17-C16-L150-2	17	2	16	150	25	8.8	APKT09T3..	TDA-014	LLT-8
NPDF90-AP09-D17-C16-L180-2R	17	2	16	180	25	8.8			
NPDF90-AP09-D20-C20-L150-3R	20	3	20	150	50	8.8			
NPDF90-AP09-D20-C20-L200-3R	20	3	20	200	100	8.8			
NPDF90-AP09-D20-C20-L250-2R	20	2	20	250	150	8.8			
NPDF90-AP09-D21-C20-L150-3	21	3	20	150	25	8.8			
NPDF90-AP09-D26-C25-L150-4	26	4	25	150	30	8.8			

Portaherramientas de fresado 90° - AP..1003

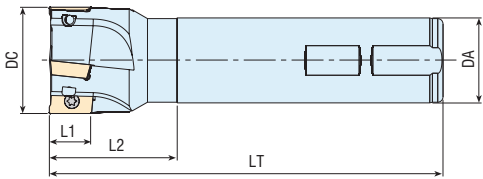

REFERENCIA	DC	Z	DA	LT	L2	L1	INSERTO	TORNILLO	LLAVE
NPDF90-AP10-D10-C10-L100-1	10	1	10	100	20	10	AP..1003..	TDA-013	LLT-8
NPDF90-AP10-D12-C16-L100-1R	12	1	16	100	30	10			
NPDF90-AP10-D12-W16-L100-1R	12	1	16	100	30	10			
NPDF90-AP10-D12-W16-L150-1	12	1	16	150	38	10			
NPDF90-AP10-D14-W16-L100-1R	14	1	16	100	30	10			
NPDF90-AP10-D14-W16-L150-1	14	1	16	150	38	10			
NPDF90-AP10-D16-C16-L100-2R	16	2	16	100	30	10			
NPDF90-AP10-D16-W16-L100-2R	16	2	16	100	30	10			
NPDF90-AP10-D16-W16-L200-2	16	2	16	200	100	10			
NPDF90-AP10-D16-C16-L120-2R	16	2	16	120	30	10			
NPDF90-AP10-D16-C16-L150-2	16	2	16	150	50	10			
NPDF90-AP10-D16-C16-L150-2R	16	2	16	150	50	10			
NPDF90-AP10-D16-W16-L150-2	16	2	16	150	50	10			
NPDF90-AP10-D16-C16-L200-2	16	2	16	200	100	10			
NPDF90-AP10-D16-C16-L200-2R	16	2	16	200	100	10			
NPDF90-AP10-D16-C16-L250-2	16	2	16	250	150	10			
NPDF90-AP10-D18-W16-L100-2R	18	2	16	100	30	10			
NPDF90-AP10-D18-W16-L150-2	18	2	16	150	30	10			
NPDF90-AP10-D20-C20-L100-3R	20	3	20	100	30	10			
NPDF90-AP10-D20-W20-L100-3R	20	3	20	100	30	10			
NPDF90-AP10-D20-C20-L120-3R	20	3	20	120	30	10			
NPDF90-AP10-D20-C20-L150-3	20	3	20	150	50	10			
NPDF90-AP10-D20-C20-L150-3R	20	3	20	150	50	10			
NPDF90-AP10-D20-W20-L150-3	20	3	20	150	50	10			
NPDF90-AP10-D20-C20-L200-2	20	2	20	200	100	10			
NPDF90-AP10-D20-C20-L200-3R	20	3	20	200	100	10			
NPDF90-AP10-D20-C20-L250-2	20	2	20	250	150	10			
NPDF90-AP10-D20-C20-L250-2R	20	2	20	250	150	10	AP..1003..	TDA-014	LLT-8
NPDF90-AP10-D21-C20-L200-3	21	3	20	200	30	10			
NPDF90-AP10-D21-W20-L150-3	21	3	20	150	30	10			
NPDF90-AP10-D22-W20-L100-3R	22	3	20	100	30	10			
NPDF90-AP10-D22-W20-L150-3	22	3	20	150	30	10			
NPDF90-AP10-D23-W20-L150-3	23	3	20	150	30	10			
NPDF90-AP10-D24-W20-L150-3	24	3	20	150	30	10			
NPDF90-AP10-D25-W25-L100-4R	25	4	25	100	30	10			
NPDF90-AP10-D25-C25-L100-3R	25	3	25	100	30	10			
NPDF90-AP10-D25-W25-L100-3R	25	3	25	100	30	10			
NPDF90-AP10-D25-C25-L120-3R	25	3	25	120	30	10			
NPDF90-AP10-D25-C25-L150-3	25	3	25	150	50	10			
NPDF90-AP10-D25-W25-L150-3	25	3	25	150	50	10			
NPDF90-AP10-D25-C25-L200-2	25	2	25	200	100	10			
NPDF90-AP10-D25-C25-L200-3	25	3	25	200	100	10			
NPDF90-AP10-D25-C25-L250-2	25	2	25	250	100	10			
NPDF90-AP10-D30-C25-L100-4R	30	5	25	100	30	10	AP..1003..	TDA-014	LLT-8
NPDF90-AP10-D30-C25-L120-4R	30	5	25	120	30	10			
NPDF90-AP10-D30-C25-L150-4	30	5	25	150	30	10			
NPDF90-AP10-D32-C25-L100-4R	32	5	25	100	35	10			
NPDF90-AP10-D32-C25-L120-4R	32	5	25	120	35	10			
NPDF90-AP10-D32-C25-L150-4	32	5	25	150	35	10			
NPDF90-AP10-D32-W25-L150-4	32	5	25	150	35	10			
NPDF90-AP10-D32-C32-L130-5	32	5	32	130	30	10			
NPDF90-AP10-D32-W32-L150-4	32	5	32	150	50	10			
NPDF90-AP10-D40-W32-L150-5	40	5	32	150	40	10			

Portaherramientas de fresado 90° - AP..11T3.. /

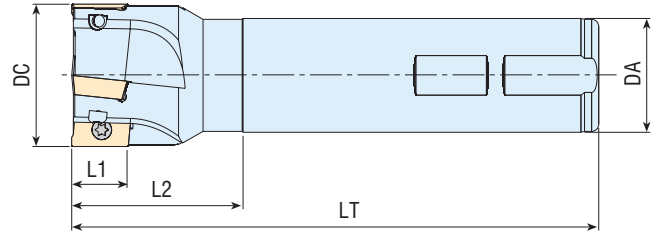

REFERENCIA	DC	Z	DA	LT	L2	L1	INSERTO	TORNILLO	LLAVE
NPDF90-AP11-D16-C16-L150-2	16	2	16	150	50	11	AP..11T3..	TDA-014	LLT-8
NPDF90-AP11-D16-C16-L150-2R	16	2	16	150	50	11			
NPDF90-AP11-D16-W16-L150-2	16	2	16	150	50	11			
NPDF90-AP11-D16-W16-L150-2R	16	2	16	150	50	11			
NPDF90-AP11-D16-C16-L200-2	16	2	16	200	100	11			
NPDF90-AP11-D17-C16-L150-2	17	2	16	150	30	11			
NPDF90-AP11-D17-C16-L200-2	17	2	16	200	30	11			
NPDF90-AP11-D20-C20-L150-3	20	3	20	150	50	11			
NPDF90-AP11-D20-W20-L150-3	20	3	20	150	50	11			
NPDF90-AP11-D20-W20-L150-3R	20	3	20	150	50	11			
NPDF90-AP11-D20-C20-L200-3	20	3	20	200	100	11			
NPDF90-AP11-D21-C20-L150-3	21	3	20	150	30	11			
NPDF90-AP11-D21-W20-L150-3	21	3	20	150	30	11			
NPDF90-AP11-D21-W20-L150-3R	21	3	20	150	30	11			
NPDF90-AP11-D21-C20-L200-3	21	3	20	200	30	11			
NPDF90-AP11-D25-C25-L150-3	25	3	25	150	50	11			
NPDF90-AP11-D25-W25-L150-3	25	3	25	150	50	11			
NPDF90-AP11-D25-W25-L150-3R	25	3	25	150	50	11			
NPDF90-AP11-D26-C25-L150-3	26	3	25	150	35	11			
NPDF90-AP11-D26-C24-L150-3	26	3	24	150	35	11			
NPDF90-AP11-D32-W25-L150-4	32	4	25	150	35	11			
NPDF90-AP11-D32-W32-L150-3R	32	3	32	150	50	11			
NPDF90-AP11-D32-W32-L150-4	32	4	32	150	50	11			
NPDF90-AP1204-D20-C20-L150-2	20	2	20	150	30	12	APM..1204..	TDA-043	LLT-10
NPDF90-AP1204-D21-C20-L150-2	21	2	20	150	30	12			
NPDF90-AP1204-D21-C20-L200-2	21	2	20	200	30	12	APM..1204..	TDA-044	LLT-10
NPDF90-AP1204-D25-C25-L150-3	25	3	25	150	40	12			
NPDF90-AP1204-D26-C25-L250-2	26	2	25	250	35	12			
NPDF90-AP1204-D32-C25-L150-3	32	5	25	150	35	12			

Portaherramientas de fresado 90° - AP..1604.. / AP..1705..

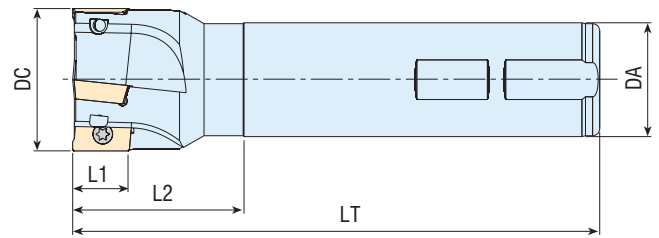

REFERENCIA	DC	Z	DA	LT	L2	L1	INSERTO	TORNILLO	LLAVE
NPDF90-AP16-D25-C20-L100-2	25	2	20	100	35	16	AP..1604..	TDA-064	LLT-15
NPDF90-AP16-D25-W25-L100-2R	25	2	25	100	35	16			
NPDF90-AP16-D25-W25-L150-2	25	2	25	150	50	16			
NPDF90-AP16-D25-C25-L250-2	25	2	25	250	100	16			
NPDF90-AP16-D28-W25-L100-3R	28	3	25	100	40	16			
NPDF90-AP16-D28-W25-L150-3	28	3	25	150	40	16			
NPDF90-AP16-D30-W25-L110-3R	30	3	25	110	40	16			
NPDF90-AP16-D30-W25-L150-2	30	2	25	150	40	16			
NPDF90-AP16-D30-W25-L150-3	30	3	25	150	40	16			
NPDF90-AP16-D32-W32-L110-3R	32	3	32	110	40	16			
NPDF90-AP16-D32-C32-L150-3	32	3	32	150	50	16			
NPDF90-AP16-D32-W25-L150-3	32	3	25	150	40	16			
NPDF90-AP16-D32-W32-L150-3	32	3	32	150	50	16			
NPDF90-AP16-D32-W32-L150-3R	32	3	32	150	50	16			
NPDF90-AP16-D32-C25-L200-3R	32	3	25	200	40	16			
NPDF90-AP16-D32-C32-L250-2	32	2	32	250	100	16			
NPDF90-AP16-D32-C32-L250-3	32	3	32	250	100	16			
NPDF90-AP16-D35-W32-L150-3	35	3	32	150	40	16			
NPDF90-AP16-D36-W32-L110-3R	36	3	32	110	40	16			
NPDF90-AP16-D36-W32-L150-3	36	3	32	150	40	16			
NPDF90-AP16-D40-W32-L110-4R	40	4	32	110	40	16			
NPDF90-AP16-D40-C32-L150-4	40	4	32	150	40	16			
NPDF90-AP16-D40-W32-L150-4	40	4	32	150	40	16			
NPDF90-AP16-D40-C32-L250-2	40	2	32	250	40	16			
NPDF90-AP16-D40-C32-L250-4	40	4	32	250	40	16			
NPDF90-AP1705-D25-C25-L120-2	25	2	25	120	40	16	AP..1705..	TDA-064	LLT-15
NPDF90-AP1705-D26-C25-L200-2	26	2	25	200	40	16			
NPDF90-AP1705-D26-C25-L250-2	26	2	25	250	40	16			
NPDF90-AP1705-D26-C25-L300-2	26	2	25	300	40	16			
NPDF90-AP1705-D28-W25-L075-2	28	2	25	75	20	16			
NPDF90-AP1705-D32-C25-L150-3	32	3	25	150	40	16			
NPDF90-AP1705-D33-C32-L250-3	33	3	32	250	40	16			
NPDF90-AP1705-D33-C32-L300-2	33	2	32	300	40	16			

Portaherramientas de fresado 90° - AO..1236..

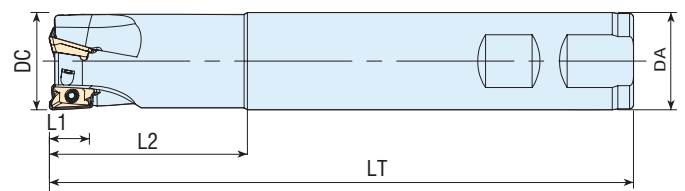

REFERENCIA	DC	Z	DA	LT	L2	L1	INSERTO	TORNILLO	LLAVE
NPDF90-AO1236-D16-C16-L85-2R	16	2	16	85	30	12	AO..1236..	TDA-014	LLT-8
NPDF90-AO1236-D16-W16-L150-2	16	2	16	150	50	10			
NPDF90-AO1236-D20-C20-L100-2R	20	2	20	100	30	12			
NPDF90-AO1236-D20-C20-L100-2	20	2	20	100	30	10			
NPDF90-AO1236-D25-C25-L115-2	25	2	25	150	50	10			
NPDF90-AO1236-D25-C25-L115-2R	25	2	25	150	50	10			
NPDF90-AO1236-D25-W25-L150-3	25	3	25	150	50	10			
NPDF90-AO1236-D32-W32-L150-4	32	4	32	150	50	10			

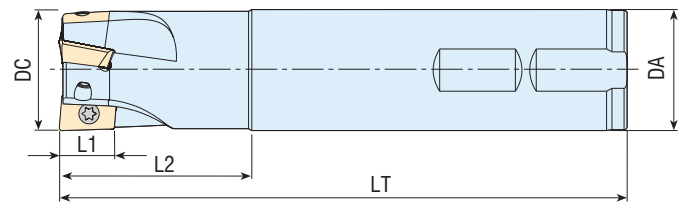
Portaherramientas de fresado 90° - AX..0602 / AX..0903

REFERENCIA	DC	Z	DA	LT	L2	L1	INSERTO	TORNILLO	LLAVE
NPDF90-AX0602-D10-C09-L120-2	10	2	9	120	20	5.7	AX..0602	TDA-002	LLT-6
NPDF90-AX0602-D10-C10-L080-2	10	2	10	80	20	5.7			
NPDF90-AX0602-D10-C10-L120-2	10	2	10	120	20	5.7			
NPDF90-AX0602-D12-C11-L120-2	12	2	11	120	20	5.7			
NPDF90-AX0602-D12-C12-L080-2	12	2	12	80	20	5.7			
NPDF90-AX0602-D12-C12-L120-2	12	2	12	120	20	5.7			
NPDF90-AX0602-D14-C12-L120-3	14	3	12	120	20	5.7			
NPDF90-AX0602-D16-W16-L120-4R	16	4	16	120	20	5.7			
NPDF90-AX0602-D16-W16-L150-4R	16	4	16	150	20	5.7			
NPDF90-AX0602-D20-W20-L120-5R	20	5	20	120	25	5.7			
NPDF90-AX0602-D20-W20-L150-5R	20	5	20	150	25	5.7			
NPDF90-AX0903-D16-C16-L120-2	16	2	16	120	30	8.8	AX..0903	TDA-013	LLT-8
NPDF90-AX0903-D16-C16-L180-2	16	2	16	180	30	8.8			
NPDF90-AX0903-D17-C16-L120-2	17	2	16	120	25	8.8			
NPDF90-AX0903-D17-C16-L180-2	17	2	16	180	25	8.8			
NPDF90-AX0903-D20-C20-L120-3	20	3	20	120	30	8.8	AX..0903	TDA-014	LLT-8
NPDF90-AX0903-D20-C20-L200-2	20	2	20	200	30	8.8			
NPDF90-AX0903-D21-C20-L120-3	21	3	20	120	25	8.8			
NPDF90-AX0903-D21-C20-L200-2	21	2	20	200	25	8.8			
NPDF90-AX0903-D25-C25-L150-3	25	3	25	150	30	8.8			
NPDF90-AX0903-D25-C25-L250-2	25	2	25	250	40	8.8			
NPDF90-AX0903-D26-C25-L150-3	26	3	25	150	30	8.8			

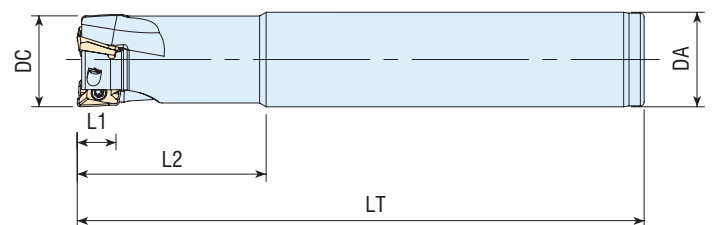
Portaherramientas de fresado 90° - AX.T1235..

REFERENCIA	DC	Z	DA	LT	L2	L1	INSERTO	TORNILLO	LLAVE
NPDF90-AX1235-D16-C14-L120-2R	16	2	14	120	25	10	AX.T1235..	TDA-025	LLT-8
NPDF90-AX1235-D16-C15-L145-2R	16	2	15	145	30	10		TDA-028	LLT-8
NPDF90-AX1235-D16-C16-L100-2R	16	2	16	100	30	10		TDA-028	LLT-8
NPDF90-AX1235-D16-C16-L140-2R	16	2	16	140	30	10		TDA-025	LLT-8
NPDF90-AX1235-D16-C16-L145-2R	16	2	16	145	30	10		TDA-028	LLT-8
NPDF90-AX1235-D16-C16-L150-2	16	2	16	150	30	10		TDA-025	LLT-8
NPDF90-AX1235-D20-C19-L150-2R	20	2	19	150	40	10		TDA-028	LLT-8
NPDF90-AX1235-D20-C20-L110-3R	20	3	20	110	40	10		TDA-028	LLT-8
NPDF90-AX1235-D20-C20-L150-2	20	2	20	150	40	10		TDA-025	LLT-8
NPDF90-AX1235-D20-C20-L150-2R	20	2	20	150	40	10		TDA-025	LLT-8
NPDF90-AX1235-D20-C20-L150-3	20	3	20	150	40	10		TDA-025	LLT-8

Portaherramientas de fresado 90° - AX.T1235.. / AX.T1705..

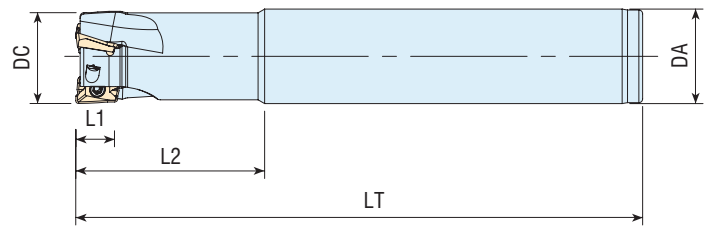

REFERENCIA	DC	Z	DA	LT	L2	L1	INSERTO	TORNILLO	LLAVE
NPDF90-AX1235-D25-C20-L120-4R	25	4	20	120	30	10	AX.T1235..	TDA-025	LLT-8
NPDF90-AX1235-D25-C20-L150-4R	25	4	20	150	30	10		TDA-025	LLT-8
NPDF90-AX1235-D25-C24-L170-2R	25	2	24	170	50	10		TDA-025	LLT-8
NPDF90-AX1235-D25-C25-L120-4R	25	4	25	120	40	10		TDA-025	LLT-8
NPDF90-AX1235-D25-C25-L150-3	25	3	25	150	50	10		TDA-028	LLT-8
NPDF90-AX1235-D25-C25-L170-2R	25	2	25	170	50	10		TDA-028	LLT-8
NPDF90-AX1235-D25-W25-L100-4R	25	4	25	100	30	10		TDA-028	LLT-8
NPDF90-AX1235-D32-C32-L130-5R	32	5	32	130	40	10		TDA-028	LLT-8
NPDF90-AX1235-D32-C32-L180-2R	32	2	32	180	50	10		TDA-028	LLT-8
NPDF90-AX1705-D25-C25-L150-2	25	2	25	150	50	14	A.XT1705..	TDA-064	LLT-15
NPDF90-AX1705-D28-W25-L115-2R	28	2	25	115	35	14			
NPDF90-AX1705-D32-C32-L150-3	32	3	32	150	50	14			
NPDF90-AX1705-D32-C32-L180-2R	32	2	32	180	50	14			

Portaherramientas de fresado 90° - AZGT1135..

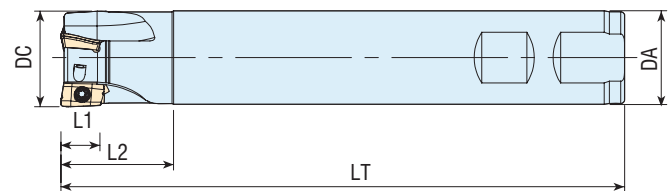

REFERENCIA	DC	Z	DA	LT	L2	L1	INSERTO	TORNILLO	LLAVE
NPDF90-AZ11-D12-W16-L90-1	12	1	16	90	30	11	AZGT1135..	TDA-013	LLT-8
NPDF90-AZ11-D16-C16-L200-2	16	2	16	200	100	11			
NPDF90-AZ11-D16-W15-L170-2	16	2	15	170	50	11			
NPDF90-AZ11-D16-W16-L100-2	16	2	16	100	35	11			
NPDF90-AZ11-D16-W16-L150-2	16	2	16	150	50	11			
NPDF90-AZ11-D17-C16-L150-2	17	2	16	150	30	11			
NPDF90-AZ11-D17-C16-L180-2	17	2	16	180	50	11			
NPDF90-AZ11-D17-W16-L100-2	17	2	16	100	30	11			
NPDF90-AZ11-D18-W16-L120-2	18	2	16	120	18	11			
NPDF90-AZ11-D20-C20-L200-3	20	3	20	200	100	11	AZGT1135..	TDA-014	LLT-8
NPDF90-AZ11-D20-W19-L170-3	20	3	19	170	50	11			
NPDF90-AZ11-D20-W20-L110-2	20	2	20	110	35	11			
NPDF90-AZ11-D21-C20-L150-3	21	3	20	150	30	11			
NPDF90-AZ11-D21-C20-L180-3	21	3	20	180	50	11			
NPDF90-AZ11-D21-W20-L110-3	21	3	20	110	35	11			
NPDF90-AZ11-D22-C20-L150-2	22	2	20	150	30	11			
NPDF90-AZ11-D25-C24-L180-4	25	4	24	180	50	11			
NPDF90-AZ11-D25-W25-L110-4	25	4	25	110	40	11			
NPDF90-AZ11-D26-C25-L250-2	26	2	25	250	50	11			
NPDF90-AZ11-D26-W25-L120-3	26	3	25	120	30	11			
NPDF90-AZ11-D26-W25-L120-4	26	4	25	120	40	11			
NPDF90-AZ11-D28-C25-L180-3	28	3	25	180	50	11			
NPDF90-AZ11-D28-C25-L250-2	28	2	25	250	50	11			
NPDF90-AZ11-D33-W32-L130-4	33	4	32	130	50	11			

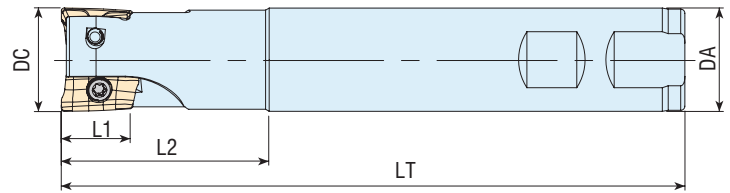
Portaherramientas de fresado 90° - BDMT11T3 / BDMT1704

REFERENCIA	DC	Z	DA	LT	L2	L1	INSERTO	TORNILLO	LLAVE
NPDF90-BD11T3-D16-C16-L100-2R	16	2	16	100	30	10	BDMT11T3..	TDA-013	LLT-8
NPDF90-BD11T3-D16-W16-L100-2R	16	2	16	100	30	10			
NPDF90-BD11T3-D16-W16-L150-2	16	2	16	150	50	10			
NPDF90-BD11T3-D16-C16-L160-2R	16	2	16	160	50	10			
NPDF90-BD11T3-D16-C15-L180-2	16	2	15	180	50	10			
NPDF90-BD11T3-D17-W16-L150-2	17	2	16	150	25	10			
NPDF90-BD11T3-D17-C16-L180-2	17	2	16	180	25	10			
NPDF90-BD11T3-D18-W16-L100-2	18	2	16	100	25	10			
NPDF90-BD11T3-D18-W16-L100-2R	18	2	16	100	25	10			
NPDF90-BD11T3-D20-W20-L81-3R	20	3	20	81	30	10	BDMT11T3..	TDA-014	LLT-8
NPDF90-BD11T3-D20-W20-L100-2R	20	2	20	100	30	10			
NPDF90-BD11T3-D20-W20-L100-3R	20	3	20	100	30	10			
NPDF90-BD11T3-D20-C20-L110-3R	20	3	20	110	30	10			
NPDF90-BD11T3-D20-W20-L150-2	20	2	20	150	50	10			
NPDF90-BD11T3-D20-W20-L150-3	20	3	20	150	50	10			
NPDF90-BD11T3-D20-W20-L150-3R	20	3	20	150	50	10			
NPDF90-BD11T3-D20-C20-L170-3R	20	3	20	170	50	10			
NPDF90-BD11T3-D21-W20-L150-3	21	3	20	150	25	10			
NPDF90-BD11T3-D21-C20-L200-2	21	2	20	200	25	10			
NPDF90-BD11T3-D22-W20-L090-2R	22	2	20	90	25	10			
NPDF90-BD11T3-D25-W25-L100-3R	25	3	25	100	30	10			
NPDF90-BD11T3-D25-C20-L120-3R	25	3	20	120	30	10			
NPDF90-BD11T3-D25-C25-L120-3R	25	3	25	120	30	10			
NPDF90-BD11T3-D25-W25-L150-3	25	3	25	150	50	10			
NPDF90-BD11T3-D26-W25-L150-3	26	3	25	150	35	10			
NPDF90-BD11T3-D26-C25-L250-2	26	2	25	250	35	10			
NPDF90-BD11T3-D32-W32-L110-4R	32	4	32	110	40	10			
NPDF90-BD11T3-D32-C32-L130-4R	32	4	32	130	40	10			
NPDF90-BD11T3-D32-W32-L150-4	32	4	32	150	50	10			
NPDF90-BD11T3-D40-W32-L110-4R	40	4	32	110	35	10			
NPDF90-BD1704-D25-W25-L100-2R	25	2	25	100	35	15.7	BDMT1704..	TDA-063	LLT-15
NPDF90-BD1704-D25-W25-L150-2	25	2	25	150	50	15.7			
NPDF90-BD1704-D25-C25-L210-2R	25	2	25	210	100	15.7			
NPDF90-BD1704-D32-W32-L110-3R	32	3	32	110	40	15.7			
NPDF90-BD1704-D32-C32-L130-3R	32	3	32	130	40	15.7			
NPDF90-BD1704-D32-W32-L130-3R	32	3	32	130	40	15.7			
NPDF90-BD1704-D32-W32-L150-3	32	3	32	150	50	15.7			
NPDF90-BD1704-D40-W32-L110-4R	40	4	32	110	40	15.7			
NPDF90-BD1704-D40-W32-L150-4	40	4	32	150	40	15.7			

Portaherramientas de fresado 90° - EDPT10T3.. / EDPT1404..

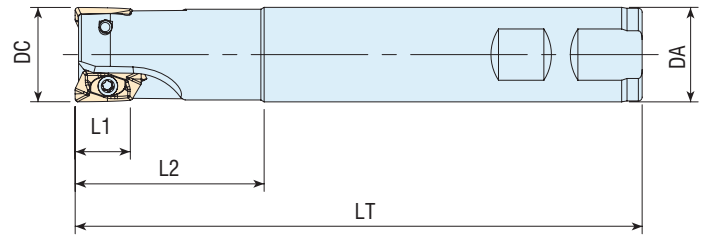

REFERENCIA	DC	Z	DA	LT	L2	L1	INSERTO	TORNILLO	LLAVE
NPDF90-ED10T3-D16-W16-L120-2	16	2	16	120	30	30	EDP10T3..	TDA-013	LLT-8
NPDF90-ED10T3-D20-W20-L120-2	20	2	20	120	30	30		TDA-014	
NPDF90-ED1404-D20-W20-L150-2	20	2	20	150	50	14.5	EDPT1404..	TDA-025	LLT-8
NPDF90-ED1404-D25-W25-L150-2	25	2	25	150	50	14.5			
NPDF90-ED1404-D30-C25-L150-3	30	3	25	150	50	14.5			

Portaherramientas de fresado 90° - LNMT0804..

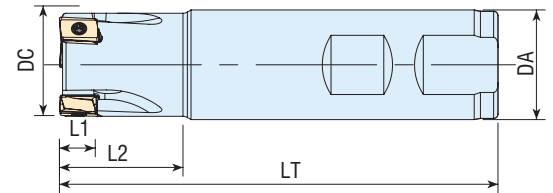

REFERENCIA	DC	Z	DA	LT	L2	L1	INSERTO	TORNILLO	LLAVE
NPDF90-LN08-D16-W16-L100-2R	16	2	16	100	28	8	LNMT0804..	TDA-094	LLT-8
NPDF90-LN08-D16-W16-L150-2	16	2	16	150	40	8			
NPDF90-LN08-D20-W20-L100-3R	20	3	20	100	28	8	LNMT0804..	TDA-094	LLT-8
NPDF90-LN08-D25-W25-L100-3R	20	3	25	100	30	8	LNMT0804..	TDA-096	LLT-8
NPDF90-LN08-D32-W32-L110-5R	25	5	32	110	30	8			

Portaherramientas de fresado 90° - LNGU15T6

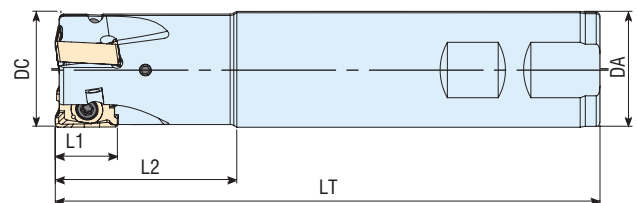

REFERENCIA	DC	Z	DA	LT	L2	L1	INSERTO	TORNILLO	LLAVE
NPDF90-LN15T6-D25-W25-L150-2R	25	2	25	150	50	15.5	LNGU15T6..	TDA-067	LLT-15
NPDF90-LN15T6-D32-W32-L150-3R	32	3	32	150	50	15.5			
NPDF90-LN15T6-D40-W32-L150-3R	40	3	32	150	40	15.5			

Portaherramientas de fresado 90° - LNMT1106..

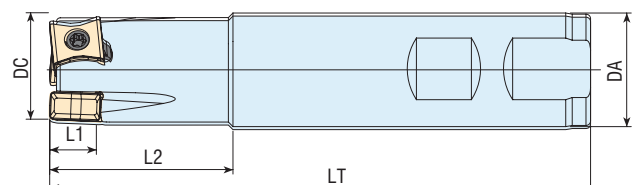

REFERENCIA	DC	Z	DA	LT	L2	L1	INSERTO	TORNILLO	LLAVE
NPDF90-LN1106-D25-W25-L150-3	25	3	25	150	40	10	LNMT1106	TDA-049	LLT-15
NPDF90-LN1106-D32-W32-L150-4	32	4	32	150	40	10			
NPDF90-LN1106-D40-W32-L150-5	40	5	32	150	40	10			

Portaherramientas de fresado 90° - LN.X1006

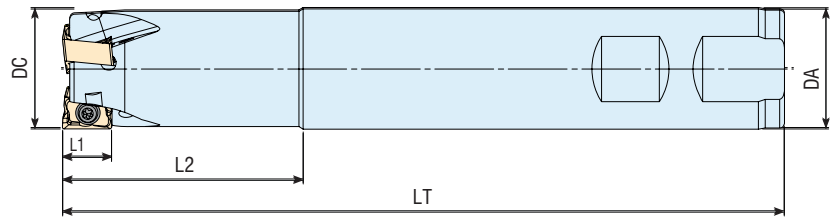

REFERENCIA	DC	Z	DA	LT	L2	L1	INSERTO	TORNILLO	LLAVE
NPDF90-LN1006-D16-W16-L120-1R	16	1	16	120	30	9	LN.X1006..	TDA-032	LLT-10
NPDF90-LN1006-D16-W16-L150-1	16	1	16	150	50	9			
NPDF90-LN1006-D18-W16-L120-2R	18	2	16	120	30	9			
NPDF90-LN1006-D20-W20-L120-2R	20	2	20	120	30	9			
NPDF90-LN1006-D20-W20-L150-2	20	2	20	150	50	9			
NPDF90-LN1006-D25-W25-L120-3R	25	3	25	120	30	9			
NPDF90-LN1006-D25-W25-L150-3	25	3	25	150	50	9			
NPDF90-LN1006-D32-W32-L120-4R	32	4	32	120	30	9			
NPDF90-LN1006-D32-W32-L150-4	32	4	32	150	50	9			

Portaherramientas de fresado 90° - R390-11T3.. / R390-1704.. / R390-1806..

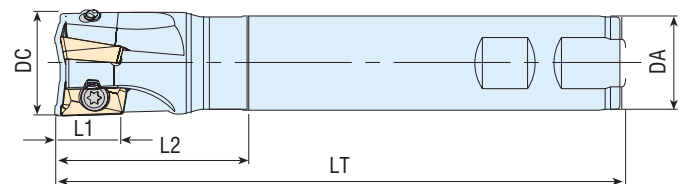

REFERENCIA	DC	Z	DA	LT	L2	L1	INSERTO	TORNILLO	LLAVE
NPDF90-R390.11-D12-W12-L100-1	12	1	12	100	25	10	R390-11T3..	TDA-013	LLT-8
NPDF90-R390.11-D16-W16-L100-2R	16	2	16	100	30	10			
NPDF90-R390.11-D16-W16-L150-2	16	2	16	150	50	10			
NPDF90-R390.11-D16-W16-L150-2R	16	2	16	150	50	10			
NPDF90-R390.11-D20-W20-L090-2R	20	2	20	90	30	10			
NPDF90-R390.11-D20-W20-L100-3R	20	3	20	100	30	10			
NPDF90-R390.11-D20-W20-L150-3	20	3	20	150	50	10	R390-11T3..	TDA-014	LLT-8
NPDF90-R390.11-D20-W20-L150-3R	20	3	20	150	50	10			
NPDF90-R390.11-D20-C20-L150-3	20	3	20	150	30	10			
NPDF90-R390.11-D22-W20-L090-2R	22	2	20	90	30	10			
NPDF90-R390.11-D25-C20-L150-3	25	3	20	150	40	10			
NPDF90-R390.11-D25-W25-L100-3R	25	3	25	100	30	10			
NPDF90-R390.11-D25-W25-L150-3	25	3	25	150	50	10			
NPDF90-R390.11-D25-W25-L150-3R	25	3	25	150	50	10			
NPDF90-R390.11-D30-W25-L150-4R	30	4	25	150	30	10			
NPDF90-R390.11-D32-C25-L200-3	32	3	25	200	40	10			
NPDF90-R390.11-D32-W32-L150-5R	32	5	32	150	50	10			
NPDF90-R390.17-D25-W25-L150-2	25	2	25	150	50	15.4	R390-1704..	TDA-046	LLT-15
NPDF90-R390.17-D25-W25-L150-2R	25	2	25	150	50	15.4		TDA-046	
NPDF90-R390.17-D30-W25-L150-3	30	3	25	150	40	15.4		TDA-046	
NPDF90-R390.17-D30-W25-L150-3R	30	3	25	150	40	15.4		TDA-047	
NPDF90-R390.17-D32-W32-L150-3R	32	3	32	150	40	15.4		TDA-047	
NPDF90-R390.18-D32-C32-L150-3	32	3	32	150	45	15.4	R390-1806..	TDA-066	LLT-15

Portaherramientas de fresado 90° - RT0702 / RT1003 / RT1606

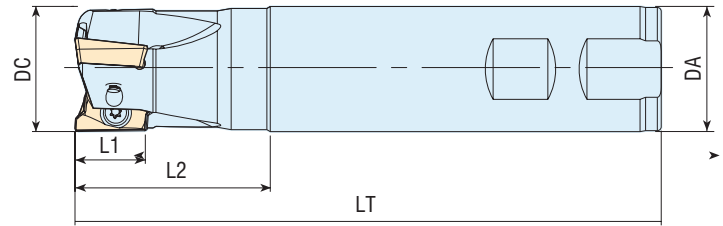

REFERENCIA	DC	Z	DA	LT	L2	L1	INSERTO	TORNILLO	LLAVE
NPDF90-RT07-D10-W10-L120-2	10	2	10	120	30	7	RT0702	TDA-006	LLT-6
NPDF90-RT07-D12-C12-L120-2	12	2	12	120	30	7			
NPDF90-RT07-D12-W12-L120-2	12	2	12	120	30	7			
NPDF90-RT07-D14-W12-L120-2	14	2	12	120	30	7			
NPDF90-RT10-D16-C15-L160-2	16	2	15	160	30	10	RT1003	TDA-014	LLT-8
NPDF90-RT10-D16-W16-L120-2R	16	2	16	120	30	10			
NPDF90-RT10-D16-W16-L150-2	16	2	16	150	30	10			
NPDF90-RT10-D16-C16-L200-2	16	2	16	200	100	10			
NPDF90-RT10-D17-W16-L160-2	17	2	16	160	30	10			
NPDF90-RT10-D17-C16-L200-2	17	2	16	200	30	10			
NPDF90-RT10-D18-W16-L120-2R	18	2	16	120	30	10			
NPDF90-RT10-D20-C19-L200-3	20	3	19	200	30	10			
NPDF90-RT10-D20-C20-L110-3	20	3	20	110	30	10			
NPDF90-RT10-D20-W20-L120-3R	20	3	20	120	30	10			
NPDF90-RT10-D20-W20-L150-3	20	3	20	150	50	10			
NPDF90-RT10-D20-C20-L200-3	20	3	20	200	100	10			
NPDF90-RT10-D21-W20-L200-3	21	3	20	200	30	10			
NPDF90-RT10-D22-W20-L120-3R	22	3	20	120	30	10			
NPDF90-RT10-D22-C20-L150-3	22	3	20	150	30	10			
NPDF90-RT10-D22-C20-L200-3	22	3	20	200	30	10			
NPDF90-RT10-D25-W25-L120-4R	25	4	25	120	40	10			
NPDF90-RT10-D25-W25-L150-4	25	4	25	150	50	10			
NPDF90-RT10-D25-C25-L200-4	25	4	25	200	100	10			
NPDF90-RT10-D26-C25-L250-4	26	4	25	250	32	10			
NPDF90-RT10-D32-W32-L120-5R	32	5	32	120	50	10			
NPDF90-RT10-D32-W32-L150-5	32	5	32	150	50	10			
NPDF90-RT10-D32-C32-L200-5	32	5	32	200	100	10			
NPDF90-RT10-D33-C32-L250-4	33	4	32	250	32	10			
NPDF90-RT16-D25-W25-L120-2R	25	2	25	120	40	16	RT1606	TDA-064	LLT-15
NPDF90-RT16-D25-W25-L150-2	25	2	25	150	50	16			
NPDF90-RT16-D25-C25-L200-2	25	2	25	200	100	16			
NPDF90-RT16-D32-W32-L120-3R	32	3	32	120	50	16			
NPDF90-RT16-D32-W32-L150-3	32	3	32	150	50	16			
NPDF90-RT16-D32-C32-L200-3	32	3	32	200	100	16			
NPDF90-RT16-D32-C32-L250-3	32	3	32	250	100	16			
NPDF90-RT16-D32-C32-L270-3	32	3	32	270	100	16			
NPDF90-RT16-D40-W32-L120-4R	40	4	32	120	50	16		TDA-066	LLT-15
NPDF90-RT16-D40-W32-L150-4	40	4	32	150	50	16			
NPDF90-RT16-D40-C32-L200-4	40	4	32	200	100	16			

Portaherramientas de fresado 90° - SEET09T3..

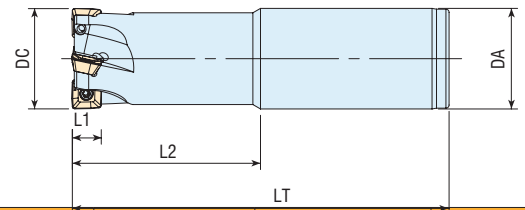

REFERENCIA	DC	Z	DA	LT	L2	L1	INSERTO	TORNILLO	LLAVE
NPDF90-SE09-D25-C25-L120-3R	25	3	25	120	60	6.7	SEET 09T3..	TDA-027	LLT-8
NPDF90-SE09-D25-C25-L150-2	25	2	25	150	50	6.7			
NPDF90-SE09-D32-C32-L120-4R	32	4	32	120	60	6.7			
NPDF90-SE09-D32-C32-L150-3	32	3	32	150	50	6.7			

Portaherramientas de fresado 90° - SOMT0803..

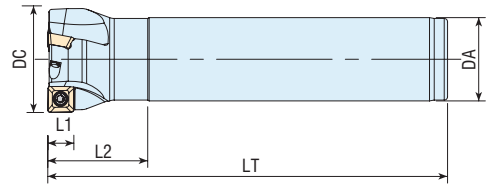

REFERENCIA	DC	Z	DA	LT	L2	L1	INSERTO	TORNILLO	LLAVE
NPDF90-SOMT08-D20-C16-L110-2R	20	2	16	110	25	7	SOMT0803..	TDA-027	LLT-8
NPDF90-SOMT08-D25-C20-L110-2R	25	2	20	110	25	7			
NPDF90-SOMT08-D32-C25-L120-3R	32	3	25	120	30	7			

Portaherramientas de fresado 90° - SPGT..

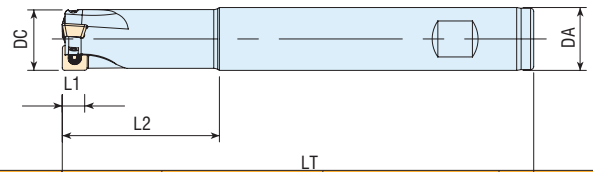

REFERENCIA	DC	Z	DA	LT	L2	L1	INSERTO	TORNILLO	LLAVE
NPDF90-SPGT0602-D16-W16-L150-2	16	2	16	150	50	5.5	SPGT060204	TDA-008	LLT-7
NPDF90-SPGT07T3-D20-W20-L150-3	20	3	20	150	50	7	SPGT07T308	TDA-014	LLT-8
NPDF90-SPGT07T3-D25-W25-L150-3	25	3	25	150	50	7			
NPDF90-SPGT0904-D30-W32-L150-3	30	3	32	150	50	9	SPGT090408	TDA-047	LLT-15

Portaherramientas de fresado 90° - TNGX1004..

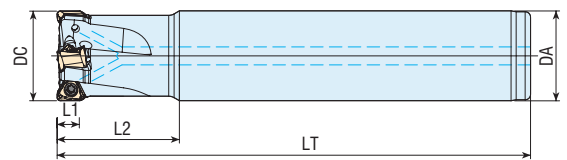

REFERENCIA	DC	Z	DA	LT	L2	L1	INSERTO	TORNILLO	LLAVE
NPDF90-TNG10-D20-C20-L125-2R	20	2	20	125	29	5	TNGX1004..	TDA-014	LLT-8
NPDF90-TNG10-D20-C20-L125-3R	20	3	20	125	29	5			
NPDF90-TNG10-D20-C20-L150-3R	20	3	20	150	50	5			
NPDF90-TNG10-D21-C20-L200-3R	21	3	20	200	30	5			
NPDF90-TNG10-D25-C25-L150-3R	25	3	25	150	34	5			
NPDF90-TNG10-D25-C25-L150-4R	25	4	25	150	34	5			
NPDF90-TNG10-D25-C25-L170-4R	25	4	25	170	50	5			
NPDF90-TNG10-D26-C25-L250-4R	26	4	25	250	35	5			
NPDF90-TNG10-D32-C32-L170-4R	32	4	32	170	37	5			
NPDF90-TNG10-D32-C32-L170-5R	32	5	32	170	37	5			
NPDF90-TNG10-D33-C32-L250-5R	33	5	32	250	35				

Portaherramientas de fresado 90° - VCKT2205..

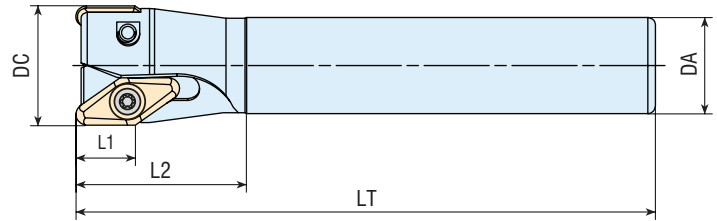

REFERENCIA	DC	Z	DA	LT	L2	L1	INSERTO	TORNILLO	LLAVE
NPDF90-VC2205-D32-C25-L150-2R	32	2	25	150	50	15	VCKT2205..	TDA-077	LLT-15
NPDF90-VC2205-D40-C32-L150-3R	40	3	32	150	50	15			

Portaherramientas de fresado 90° - WNGU0403 / WNGU0806

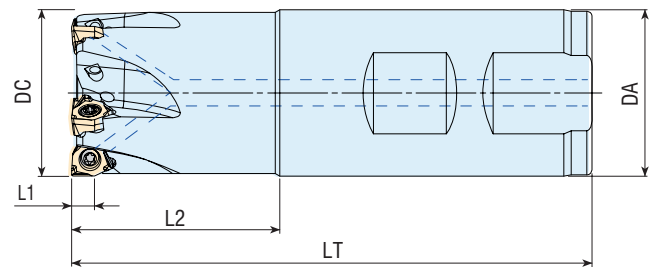

REFERENCIA	DC	Z	DA	LT	L2	L1	INSERTO	TORNILLO	LLAVE
NPDF90-WNG04-D20-W20-L81-3R	20	3	20	81	31	4	WNGU0403..	TDA-014	LLT-8
NPDF90-WNG04-D20-C20-L170-3R	20	3	20	170	50	4			
NPDF90-WNG04-D25-W25-L88-3R	25	3	25	88	32	4			
NPDF90-WNG04-D25-W25-L88-4R	25	4	25	88	32	4			
NPDF90-WNG04-D25-C25-L170-3R	25	3	25	170	50	4			
NPDF90-WNG04-D32-W25-L100-5R	32	5	25	100	35	4			
NPDF90-WNG04-D32-W32-L100-5R	32	5	32	100	40	4			
NPDF90-WNG04-D32-C25-L170-4R	32	4	25	170	35	4			
NPDF90-WNG04-D32-C32-L170-4R	32	4	32	170	50	4			
NPDF90-WNG08-D40-W32-L100-3R	40	3	32	100	35	7.5	WNGU0806..	TDA-066	LLT-15
NPDF90-WNG08-D40-C32-L170-3R	40	3	32	170	35	7.5			

Portaherramientas de fresado 90° - WNHU0604..

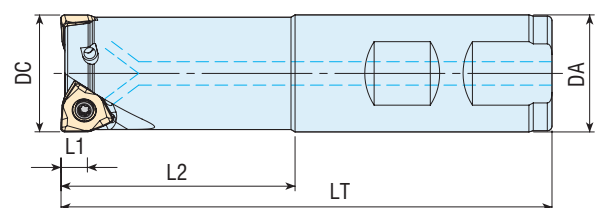

REFERENCIA	DC	Z	DA	LT	L2	L1	INSERTO	TORNILLO	LLAVE
NPDF90-WNHU06-D25-W25-L150-2R	25	2	25	150	50	5.7	WNGU0403..	TDA-014	LLT-8
NPDF90-WNHU06-D32-W32-L150-3R	32	3	32	150	50	5.7			
NPDF90-WNHU06-D40-W32-L150-4R	40	4	32	150	35	5.7			

Portaherramientas de fresado 90° - XD.T11T3..

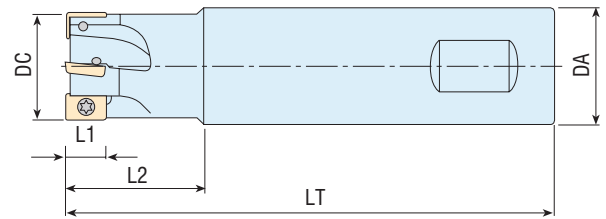

REFERENCIA	DC	Z	DA	LT	L2	L1	INSERTO	TORNILLO	LLAVE
NPDF90-XD11T3-D16-W16-L150-2	16	2	16	150	30	10	XD.T11T3..	TDA-013	LLT-8
NPDF90-XD11T3-D17-C16-L150-2	17	2	16	150	30	10			
NPDF90-XD11T3-D20-W20-L150-3	20	3	20	150	50	10		TDA-014	LLT-8
NPDF90-XD11T3-D21-C20-L080-3R	21	3	20	80	25	10			
NPDF90-XD11T3-D21-C20-L150-3	21	3	20	150	30	10			
NPDF90-XD11T3-D25-W25-L150-4	25	4	25	150	50	10			
NPDF90-XD11T3-D30-W25-L120-4	30	4	25	120	30	10			
NPDF90-XD11T3-D32-W32-L150-4	32	4	32	150	50	10			
NPDF90-XD11T3-D33-C20-L080-4R	33	4	20	80	30	10			

Portaherramientas de fresado 90° - XCKX13T3

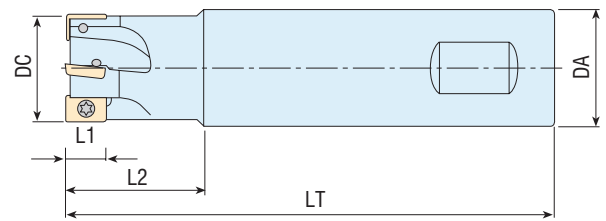

REFERENCIA	DC	Z	DA	LT	L2	L1	INSERTO	TORNILLO	LLAVE
NPDF90-XC13-D20-W20-L150-2	20	2	20	150	60	13	XCKX13T3..	TDA-025	LLT-8
NPDF90-XC13-D25-W25-L150-3	25	3	25	150	60	13		TDA-027	LLT-8
NPDF90-XC13-D32-W32-L150-Z	32	4	32	150	60	13			

Portaherramientas de fresado 90° - XO..0602.. / XO..0903.. / XO..1204..

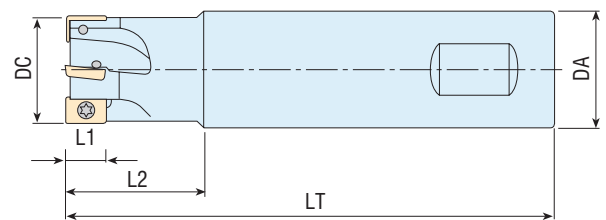

REFERENCIA	DC	Z	DA	LT	L2	L1	INSERTO	TORNILLO	LLAVE
NPDF90-XO06-D10-C12-L120-2	10	2	12	120	50	5	XO..0602..	TDA-002	LLT-6
NPDF90-XO06-D12-C12-L120-2	12	2	12	120	25	5			
NPDF90-XO09-D16-W16-L150-2	16	2	16	150	50	8	XO..0903..	TDA-013	LLT-8
NPDF90-XO09-D20-W20-L150-3	20	3	20	150	50	8			
NPDF90-XO12-D20-W20-L150-2	20	2	20	150	50	11	XO..1204..	TDA-043	LLT-10
NPDF90-XO12-D20-C20-L200-2	20	2	20	200	100	11			
NPDF90-XO12-D22-W20-L150-2	22	2	20	150	30	11			
NPDF90-XO12-D25-W25-L150-3	25	3	25	150	50	11			
NPDF90-XO12-D25-C25-L200-3	25	3	25	200	100	11			
NPDF90-XO12-D32-C25-L150-4	32	4	25	150	40	11			
NPDF90-XO12-D32-W32-L150-4	32	4	32	150	50	11			
NPDF90-XO12-D32-C32-L250-4	32	4	32	250	100	11			

Portaherramientas de fresado 90° - XNEX0403.. / XNEX0806..

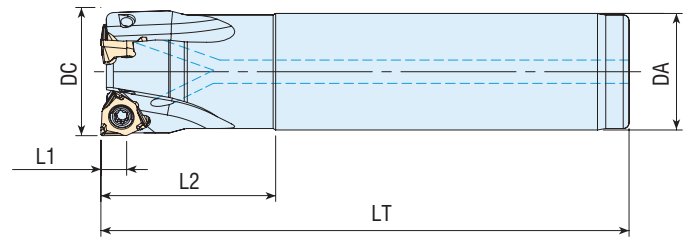

REFERENCIA	DC	Z	DA	LT	L2	L1	INSERTO	TORNILLO	LLAVE
NPDF90-XN0403-D16-C16-L100-1R	16	1	16	100	30	4	XNEX0403..	TDA-014	LLT-8
NPDF90-XN0403-D22-C20-L110-3R	22	3	20	110	30	4			
NPDF90-XN0806-D32-C32-L110-2R	32	2	32	110	40	7.5	XNEX0806..	TDA-066	LLT-15

Portaherramientas de fresado 90° - ZCMT1003R

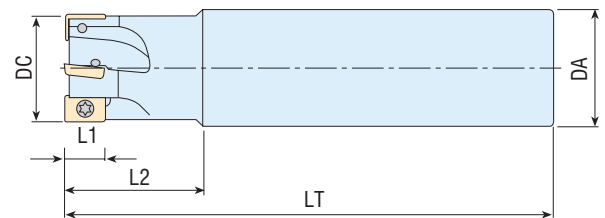

REFERENCIA	DC	Z	DA	LT	L2	L1	INSERTO	TORNILLO	LLAVE
NPDF90-ZC1003-D16-C14-L150-2	16	2	14	150	25	9	ZCMT100308R	TDA-014	LLT-8
NPDF90-ZC1003-D16-C14-L200-2	16	2	14	200	25	9			
NPDF90-ZC1003-D16-C15-L150-2	16	2	15	150	25	9			
NPDF90-ZC1003-D16-C16-L150-2	16	2	16	150	25	9			
NPDF90-ZC1003-D16-C16-L200-2	16	2	16	200	50	9			
NPDF90-ZC1003-D17-C16-L150-2	17	2	16	150	25	9			
NPDF90-ZC1003-D17-C16-L200-2	17	2	16	200	25	9			
NPDF90-ZC1003-D20-C18-L150-3	20	3	18	150	25	9			
NPDF90-ZC1003-D20-C18-L200-2	20	2	18	200	25	9			
NPDF90-ZC1003-D20-C20-L150-3	20	3	20	150	40	9			
NPDF90-ZC1003-D20-C18-L200-3	20	3	18	200	25	9			
NPDF90-ZC1003-D21-C20-L150-2	21	2	20	150	30	9			
NPDF90-ZC1003-D21-C20-L150-3	21	3	20	150	30	9			
NPDF90-ZC1003-D21-C20-L200-3	21	3	20	200	30	9			
NPDF90-ZC1003-D25-C20-L150-3	25	3	20	150	30	9			
NPDF90-ZC1003-D25-C20-L200-3	25	3	20	200	30	9			
NPDF90-ZC1003-D25-C25-L150-3	25	3	25	150	40	9			
NPDF90-ZC1003-D26-C25-L170-3	26	3	25	170	25	9			
NPDF90-ZC1003-D26-C25-L200-3	26	3	25	200	25	9			
NPDF90-ZC1003-D32-C25-L180-4	32	4	25	180	30	9			
NPDF90-ZC1003-D33-C32-L200-4	33	4	32	200	25	9			

Portaherramientas de fresado 90° - 3P..0603 / 3P..1004 / 3P..1505

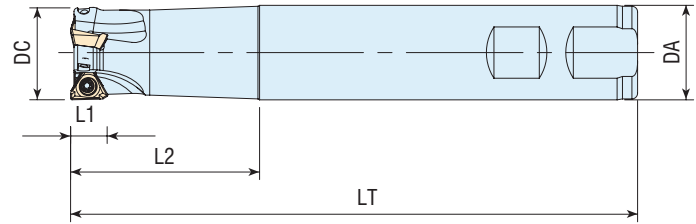

REFERENCIA	DC	Z	DA	LT	L2	L1	INSERTO	TORNILLO	LLAVE
NPDF90-3P0603-D16-W16-L120-3R	16	3	16	120	25	4.7	3P.T0603..	TDA-006	LLT-6
NPDF90-3P0603-D20-W20-L150-3R	20	3	20	150	25	4.7			
NPDF90-3P0603-D25-W25-L150-5R	25	5	25	150	25	4.7			
NPDF90-3P1004-D20-W20-L150-2	20	2	20	150	40	7	3P.T1004	TDA-012	LLT-8
NPDF90-3P1004-D21-C20-L200-2	21	2	20	200	30	7			
NPDF90-3P1004-D25-W25-L150-3	25	3	25	150	40	7			
NPDF90-3P1505-D32-W32-L150-3	32	3	32	150	50	11	3P.T1505	TDA-056	LLT-15
NPDF90-3P1505-D38-W32-L150-3	38	3	32	150	35	11			
NPDF90-3P1505-D40-W32-L150-4	40	4	32	150	35	11			

Portaherramientas de fresado 90° - 4NK0603..

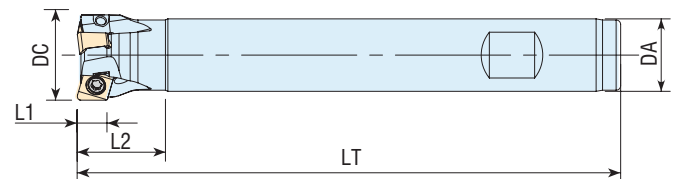

REFERENCIA	DC	Z	DA	LT	L2	L1	INSERTO	TORNILLO	LLAVE
NPDF90-4N06-D16-W16-L120-2R	16	2	16	120	25	6	4NK0603..	TDA-024	LLT-8
NPDF90-4N06-D16-W16-L160-2	16	2	16	160	25	6			
NPDF90-4N06-D20-W16-L120-3R	20	3	16	120	20	6			
NPDF90-4N06-D20-W16-L160-3	20	3	16	160	2	6			

Portaherramientas de fresado - Placa Redonda RPMT

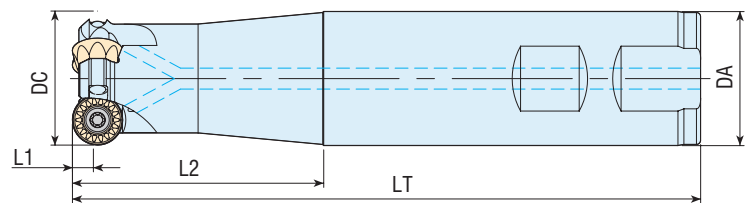

REFERENCIA	DC	Z	DA	LT	L2	L1	INSERTO	TORNILLO	LLAVE
NPDFC-RP08T2M-D20-W20-L150-2R	20	2	20	150	60	4	RPMT08T2..	TDA-014	LLT-8
NPDFC-RP08T2M-D25-W25-L200-3R	25	3	25	200	100	4			
NPDFC-RP10T3M-D25-W25-L200-2R	25	2	25	200	100	5	RPMT10T3..	TDA-047	LLT-15
NPDFC-RP10T3M-D32-W32-L200-3R	32	3	32	200	100	5			
NPDFC-RP1204M-D32-W32-L150-3R	32	3	32	150	60	6	RPMT1204..	TDA-064	LLT-15
NPDFC-RP1204M-D32-W32-L200-3R	32	3	32	200	100	6			
NPDFC-RP1606M-D40-W32-L150-2R	40	2	16	150	35	8	RPMT1606	TDA-081	LLT-20
NPDFC-RP1606M-D40-W32-L200-2R	40	2	16	200	35	8			

Portaherramientas de fresado - Placa Redonda RD...

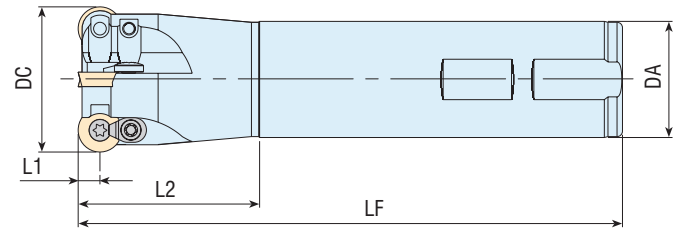

REFERENCIA	DC	Z	DA	LT	L2	L1	INSERTO	TORNILLO	BRIDA	TORNILLO BRIDA	LLAVE
NPDFC-RD0501-D08-W10-L100-1R	8	1	10	100	20	2.5	RD..0501	TDA-005	-	-	LLT-6
NPDFC-RD0501-D10-W12-L100-2R	10	2	12	100	20	2.5		TDA-006	-	-	LLT-6
NPDFC-RD0501-D12-W12-L120-2R	12	2	12	120	20	2.5					
NPDFC-RD0803-D16-W16-L150-2	16	2	16	150	60	4	RD..0803	TDA-025	-	-	LLT-8
NPDFC-RD0803-D16-C20-L200-2	16	2	20	200	60	4					
NPDFC-RD0803-D20-W20-L150-3	20	3	20	150	60	4					
NPDFC-RD08T2-D16-W16-L150-2	16	2	16	150	60	4	RD..08T2	TDA-014	-	-	LLT-8
NPDFC-RD08T2-D20-W20-L150-2	20	2	20	150	60	4					
NPDFC-RD1003-D20-W20-L150-2	20	2	20	150	60	5	RD..1003	TDA-047	BDA-26	TDA-049	LLT-15
NPDFC-RD1003-D20-C20-L160-2	20	2	20	160	70	5					
NPDFC-RD1003-D20-C20-L250-2	20	2	20	250	150	5					
NPDFC-RD1003-D21-C20-L160-2	21	2	20	160	70	5					
NPDFC-RD1003-D25-W25-L150-2	25	2	25	150	60	5					
NPDFC-RD1003-D25-C25-L160-2	25	2	25	160	70	5					
NPDFC-RD1003-D25-W25-L200-2	25	2	25	200	100	5					
NPDFC-RD1003-D25-C25-L200-2	25	2	25	200	100	5					
NPDFC-RD1003-D25-C25-L250-2	25	2	25	250	150	5					
NPDFC-RD1003-D26-C25-L160-2	26	2	25	160	70	5					
NPDFC-RD1003-D32-W32-L150-3	32	3	32	150	60	5					
NPDFC-RD1003-D32-C32-L250-2	32	2	32	250	150	5					
NPDFC-RD1003-D33-C32-L160-3	33	3	32	160	70	5					
NPDFC-RD1003-D40-W32-L150-4	40	4	32	150	35	5					
NPDFC-RD1003-D40-C32-L250-2	40	2	32	250	50	5					
NPDFC-RD10T3-D20-C20-L150-2	20	2	20	150	60	5	RD..10T3	TDA-047	BDA-26	TDA-049	LLT-15
NPDFC-RD10T3-D20-W20-L150-2	20	2	20	150	60	5					
NPDFC-RD10T3-D25-C25-L150-2	25	2	25	150	60	5					
NPDFC-RD10T3-D25-C25-L200-2R	25	2	25	200	100	5					
NPDFC-RD10T3-D25-W25-L150-2	25	2	25	150	60	5					
NPDFC-RD10T3-D32-C25-L250-3R	32	3	25	250	35	5					
NPDFC-RD10T3-D32-W32-L150-3	32	3	32	150	60	5					
NPDFC-RD12T3-D25-W25-L150-2	25	2	25	150	60	6	RD..12T3	TDA-047	BDA-26	TDA-049	LLT-15
NPDFC-RD12T3-D25-W25-L200-2	25	2	25	200	100	6					
NPDFC-RD12T3-D25-C25-L250-2	25	2	25	250	150	6					
NPDFC-RD12T3-D25-C25-L300-2	25	2	25	300	200	6					
NPDFC-RD12T3-D32-W32-L150-3	32	3	32	150	60	6					
NPDFC-RD12T3-D32-C32-L250-2	32	2	32	250	150	6					
NPDFC-RD12T3-D40-W32-L150-4	40	4	32	150	50	6					
NPDFC-RD12T3-D40-C32-L250-2	40	2	32	250	50	6					
NPDFC-RD1204-D32-C32-L160-3	32	3	32	160	70	6	RD..1204	TDA-047	BDA-26	TDA-049	LLT-15
NPDFC-RD1204-D32-W32-L160-3	32	3	32	160	70	6					
NPDFC-RD1204-D33-C32-L160-3	33	3	32	160	70	6					
NPDFC-RD1604-D40-W32-L150-2	40	2	32	150	35	8	RD..1604	TDA-077	BDA-18	TDA-066	LLT-15

Portaherramientas de fresado - Placa Redonda QP..10T3 / QP..1204

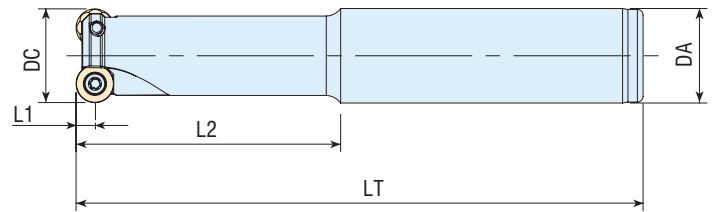

REFERENCIA	DC	Z	DA	LT	L2	L1	INSERTO	TORNILLO	LLAVE
NPDFC-QP10T3-D20-C20-L150-1R	20	1	20	150	70	5	QP..10T3..	TDA-047	LLT-15
NPDFC-QP10T3-D25-C25-L120-2R	25	2	25	120	40	5			
NPDFC-QP10T3-D25-C25-L150-2R	25	2	25	150	70	5			
NPDFC-QP10T3-D25-C25-L170-2	25	2	25	170	90	5			
NPDFC-QP10T3-D32-C32-L150-3R	32	3	32	150	70	5			
NPDFC-QP10T3-D32-C32-L170-3	32	3	32	170	90	5			
NPDFC-QP1204-D25-C25-L150-2R	25	2	25	150	70	6	QP..1204..	TDA-064	LLT-15

Portaherramientas de fresado - Placa Redonda RPNX10T3

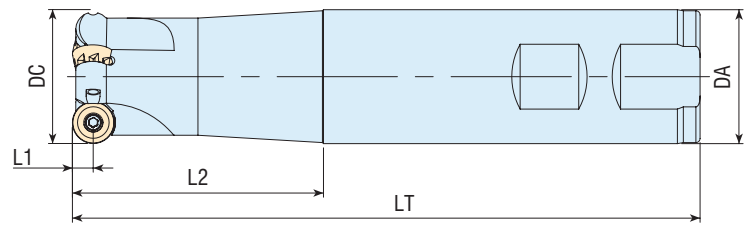

REFERENCIA	DC	Z	DA	LT	L2	L1	INSERTO	TORNILLO	LLAVE
NPDFC-RP10T3-D25-W25-L125-2	25	2	25	125	60	5	RPNX10T3..	TDA-032	80-T10
NPDFC-RP10T3-D25-W25-L150-2	25	2	25	150	60	5			
NPDFC-RP10T3-D32-W32-L150-3	32	3	32	150	60	5			

Portaherramientas de fresado - Placa BNGX10T3

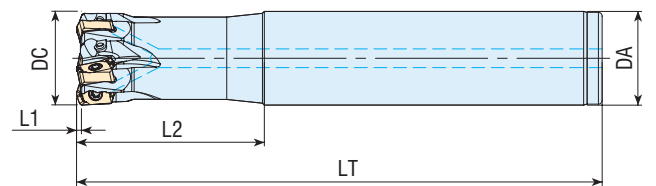

REFERENCIA	DC	Z	DA	LT	L2	L1	INSERTO	TORNILLO	LLAVE
NPDF-BN10T3-D16-C16-L100-2R	16	2	16	100	30	1	BNGX10T3..	TDA-014	LLT-8
NPDF-BN10T3-D16-C16-L150-2R	16	2	16	150	50	1			
NPDF-BN10T3-D20-C20-L130-3R	20	3	20	130	40	1			
NPDF-BN10T3-D20-C20-L130-4R	20	4	20	130	40	1			
NPDF-BN10T3-D20-C20-L160-3R	20	3	20	160	80	1			
NPDF-BN10T3-D25-C25-L140-4R	25	4	25	140	50	1			
NPDF-BN10T3-D25-W25-L140-4R	25	4	25	140	50	1			
NPDF-BN10T3-D25-C25-L140-5R	25	5	25	140	50	1			
NPDF-BN10T3-D25-C25-L180-4R	25	4	25	180	100	1			
NPDF-BN10T3-D32-C32-L150-5R	32	5	32	150	70	1			
NPDF-BN10T3-D32-C32-L150-6R	32	6	32	150	70	1			
NPDF-BN10T3-D35-C32-L200-6R	35	6	32	200	50	1			

Portaherramientas de fresado - Placa EO..0602 / ZOMT0602..

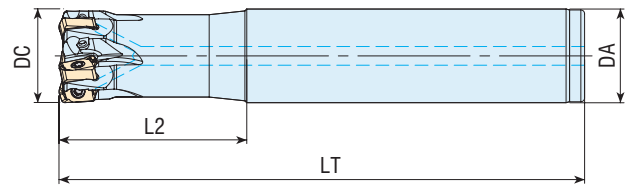

REFERENCIA	DC	Z	DA	LT	L2	L1	INSERTO	TORNILLO	LLAVE
NPDF-EO0602-D10-C10-L080-2	10	2	10	80	20	-	EO..0602..	TDA-002	LLT-6
NPDF-EO0602-D10-C09-L120-2	10	2	9	120	15	-	ZOMT0602..		
NPDF-EO0602-D10-C10-L120-2	10	2	10	120	60	-			
NPDF-EO0602-D12-C12-L080-2	12	2	12	80	20	-			
NPDF-EO0602-D12-C12-L080-3	12	3	12	80	20	-			
NPDF-EO0602-D12-C11-L120-2	12	2	11	120	15	-			
NPDF-EO0602-D12-C11-L120-3	12	3	11	120	15	-			
NPDF-EO0602-D12-C12-L120-2	12	2	12	120	60	-			
NPDF-EO0602-D12-C12-L120-3	12	3	12	120	60	-			
NPDF-EO0602-D16-C16-L150-4	16	4	16	150	60	-			

Portaherramientas de fresado - Placa EP..1003 / ZPMT1003 / YPHW1003

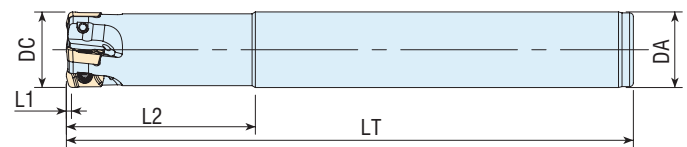

REFERENCIA	DC	Z	DA	LT	L2	L1	INSERTO	TORNILLO	LLAVE
NPDF-EP1003-D16-C16-L150-2R	16	2	16	150	50	1	EP.. 1003..	TDA-013	LLT-3
NPDF-EP1003-D17-C16-L150-2R	17	2	16	150	20	1	ZPMT 1003..		
NPDF-EP1003-D20-C20-L150-4R	20	4	20	150	50	1	YPHW 1003..		
NPDF-EP1003-D21-C20-L150-4R	21	4	20	150	20	1			
NPDF-EP1003-D25-C25-L200-4R	25	4	25	200	100	1			
NPDF-EP1003-D25-C25-L250-4R	25	4	25	250	100	1			

Portaherramientas de fresado - Placa JDMW1204..

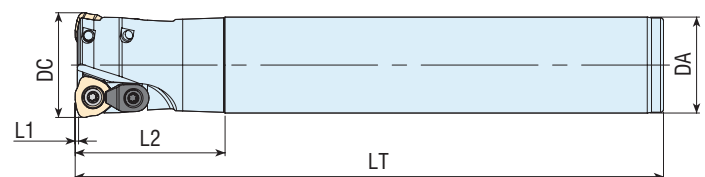

REFERENCIA	DC	Z	DA	LT	L2	L1	INSERTO	TORNILLO	BRIDA	TORNILLO BRIDA	LLAVE
NPDFC-JD1204-D32-C32-L150-2	32	2	32	150	50	1	JDMW 1204..	TDA-071	BDA-18	TDA-066	LLT-15
NPDFC-JD1204-D32-C32-L200-2	32	2	32	200	50	1					
NPDFC-JD1204-D35-C32-L200-2	35	2	32	200	50	1					
NPDFC-JD1204-D35-C32-L250-2	35	2	32	250	50	1					

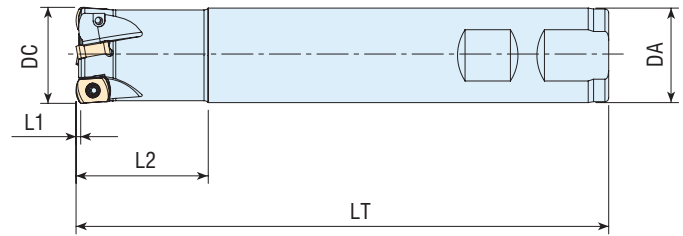
Portaherramientas de fresado - Placa BLMP0603..

REFERENCIA	DC	Z	DA	LT	L2	L1	INSERTO	TORNILLO	LLAVE
NPDF-BL0603-D16-C15-L150-2	16	2	15	150	20	1	BLBP0603..	TDA-014	LLT-8
NPDF-BL0603-D16-C16-L100-2R	16	2	16	100	30	1			
NPDF-BL0603-D16-C16-L150-2	16	2	16	150	50	1			
NPDF-BL0603-D17-C16-L150-2	17	2	16	150	20	1			
NPDF-BL0603-D17-W16-L170-2	17	2	16	170	20	1			
NPDF-BL0603-D17-W16-L170-2R	17	2	16	170	20	1			
NPDF-BL0603-D17-C16-L200-2	17	2	16	200	30	1			
NPDF-BL0603-D18-C16-L150-2	18	2	16	150	20	1			
NPDF-BL0603-D18-W16-L150-2R	18	2	16	150	20	1			
NPDF-BL0603-D20-C20-L130-3	20	3	20	130	50	1			
NPDF-BL0603-D20-C20-L160-3	20	3	20	160	50	1			
NPDF-BL0603-D21-C20-L200-3	21	3	20	200	25	1			
NPDF-BL0603-D21-W20-L200-3	21	3	20	200	25	1			
NPDF-BL0603-D22-W20-L150-3	22	3	20	150	20	1			
NPDF-BL0603-D25-C25-L250-4	25	4	25	250	40	1			
NPDF-BL0603-D26-C25-L200-4	26	4	25	200	35	1			
NPDF-BL0603-D26-W25-L200-4	26	4	25	200	35	1			
NPDF-BL0603-D26-C25-L250-4	26	4	25	250	35	1			
NPDF-BL0603-D32-C32-L150-5	32	5	32	150	70	1			
NPDF-BL0603-D32-C32-L200-5	32	5	32	200	120	1			
NPDF-BL0603-D33-C32-L150-5	33	5	32	150	40	1			
NPDF-BL0603-D33-C32-L200-5	33	5	32	200	40	1			
NPDF-BL0603-D33-C32-L250-5	33	5	32	250	40	1			

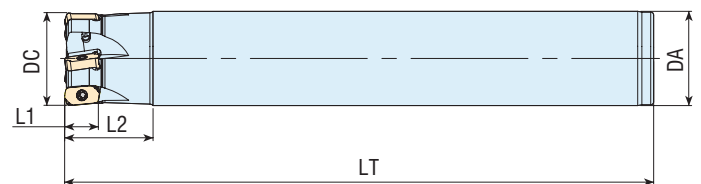
Portaherramientas de fresado - Placa Redonda LNMU0303..

REFERENCIA	DC	Z	DA	LT	L2	L1	INSERTO	TORNILLO	LLAVE
NPDF-LN0303-D16-C15-L150-2	16	2	15	150	30	12	LNMU0303	TDA-014	LLT-8
NPDF-LN0303-D16-W16-L150-2R	16	2	16	150	50	12			
NPDF-LN0303-D20-W20-L150-3R	20	3	20	150	50	12			
NPDF-LN0303-D21-C20-L150-3	21	3	20	150	30	12			
NPDF-LN0303-D25-W25-L150-4R	25	4	25	150	50	12			
NPDF-LN0303-D26-C25-L150-4	26	4	25	150	30	12			
NPDF-LN0303-D33-C32-L200-5	33	5	32	200	30	12			

Portaherramientas de fresado - Placa ENMU1004..

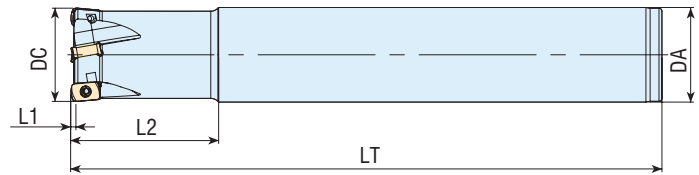

REFERENCIA	DC	Z	DA	LT	L2	L1	INSERTO	TORNILLO	LLAVE
NPDF-EN1004-D16-C15-L150-2	16	2	15	150	25	1	ENMU1004..	TDA-013	LLT-8
NPDF-EN1004-D16-C16-L150-2	16	2	16	150	25	1			
NPDF-EN1004-D16-C16-L250-2	16	2	16	250	70	1			
NPDF-EN1004-D17-C16-L150-2R	17	2	16	150	25	1			
NPDF-EN1004-D17-C16-L150-2	17	2	16	150	25	1			
NPDF-EN1004-D17-C16-L200-2	17	2	16	200	25	1			
NPDF-EN1004-D18-C16-L150-2	18	2	16	150	25	1			
NPDF-EN1004-D20-C20-L150-3	20	3	20	150	40	1			
NPDF-EN1004-D20-C20-L250-3	20	3	20	250	70	1			
NPDF-EN1004-D21-C20-L150-2	21	2	20	150	30	1			
NPDF-EN1004-D21-C20-L150-3	21	3	20	150	30	1			
NPDF-EN1004-D21-C20-L150-3R	21	3	20	150	30	1			
NPDF-EN1004-D21-C20-L200-3	21	3	20	200	30	1			
NPDF-EN1004-D22-C20-L150-3	22	3	20	150	30	1	ENMU1004..	TDA-014	LLT-8
NPDF-EN1004-D25-C25-L150-3	25	3	25	150	40	1			
NPDF-EN1004-D25-C25-L150-4	25	4	25	150	40	1			
NPDF-EN1004-D26-C25-L150-3	26	3	25	150	30	1			
NPDF-EN1004-D26-C25-L150-4	26	4	25	150	30	1			
NPDF-EN1004-D26-C25-L200-3	26	3	25	150	30	1			
NPDF-EN1004-D26-C25-L200-3R	26	3	25	200	30	1			
NPDF-EN1004-D26-C25-L250-3R	26	3	25	250	30	1			
NPDF-EN1004-D28-C25-L200-4	28	4	25	200	30	1			
NPDF-EN1004-D32-C32-L200-4	32	4	32	200	50	1			
NPDF-EN1004-D33-C32-L200-4	33	4	32	200	30	1			
NPDF-EN1004-D33-C32-L200-4R	33	4	32	200	30	1			

Portaherramientas de fresado - Placa LPGT0102....

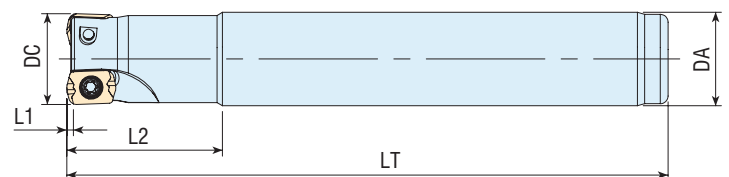

REFERENCIA	DC	Z	DA	LT	L2	L1	INSERTO	TORNILLO	LLAVE
NPDF-LP0102-D10-C09-L120-2	10	2	9	120	20	0.5	LPGT0102..	TDA-002	LLT-6
NPDF-LP0102-D10-C10-L120-2	10	2	10	120	20	0.5			
NPDF-LP0102-D12-C11-L120-2	12	2	11	120	20	0.5			
NPDF-LP0102-D12-C12-L120-2	12	2	12	120	20	0.5			

Portaherramientas de fresado - Placa LOGU0303..

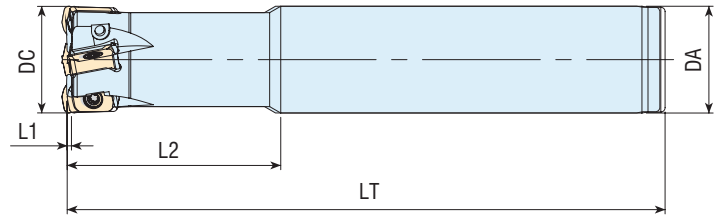

REFERENCIA	DC	Z	DA	LT	L2	L1	INSERTO	TORNILLO	LLAVE
NPDF-LO03-D16-C15-L160-2	16	2	15	15	30	1	LOGU0303..	TDA-024	LLT-8
NPDF-LO03-D16-C16-L100-2	16	2	16	16	30	1			
NPDF-LO03-D16-C16-L130-2R	16	2	16	16	40	1			
NPDF-LO03-D16-C16-L160-2	16	2	16	16	50	1			
NPDF-LO03-D16-C16-L160-2R	16	2	16	16	100	1			
NPDF-LO03-D17-C16-L180-2	17	2	16	16	30	1			
NPDF-LO03-D20-C20-L130-3	20	3	20	20	40	1			
NPDF-LO03-D20-C20-L130-3R	20	3	20	20	40	1			
NPDF-LO03-D20-C20-L160-3	20	3	20	20	80	1			
NPDF-LO03-D20-C20-L160-3R	20	3	20	20	100	1			
NPDF-LO03-D21-C20-L150-3R	21	3	20	20	30	1			
NPDF-LO03-D21-C20-L200-3	21	3	20	20	30	1			
NPDF-LO03-D21-C20-L200-3R	21	3	20	20	30	1			
NPDF-LO03-D25-C25-L140-4	25	4	25	25	50	1			
NPDF-LO03-D25-C25-L180-4	25	4	25	25	100	1			
NPDF-LO03-D26-C25-L250-4	26	4	25	25	40	1			
NPDF-LO03-D32-C32-L200-5	32	5	32	32	120	1			
NPDF-LO03-D33-C32-L250-5	33	5	32	32	40	1			

Portaherramientas de fresado - Placa SD..06T2

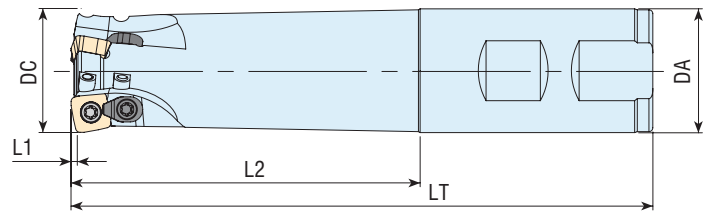

REFERENCIA	DC	Z	DA	LT	L2	L1	INSERTO	TORNILLO	LLAVE
NPDF-SD06T2-D16-C16-L100-2R	16	2	16	100	50	0.8	SD..06T2..	TDA-008	LLT-7
NPDF-SD06T2-D16-C16-L150-2R	16	2	16	150	50	0.8			
NPDF-SD06T2-D16-C16-L200-2	16	2	16	200	100	0.8			
NPDF-SD06T2-D17-C16-L150-2R	17	2	16	150	50	0.8			
NPDF-SD06T2-D20-C20-L150-3R	20	3	20	150	50	0.8			
NPDF-SD06T2-D20-C20-L200-3	20	3	20	200	100	0.8			
NPDF-SD06T2-D21-C20-L150-3R	21	3	20	150	50	0.8			
NPDF-SD06T2-D25-C25-L150-4R	25	4	25	150	60	0.8			
NPDF-SD06T2-D26-C25-L150-4R	26	4	25	150	60	0.8			

Portaherramientas de fresado - Placa SD..09T3

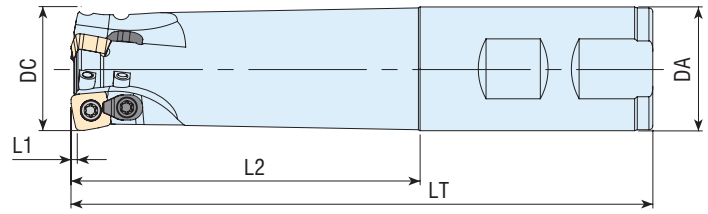

REFERENCIA	DC	Z	DA	LT	L2	L1	INSERTO	TORNILLO	BRIDA	TORNILLO BRIDA	LLAVE
NPDF-SD09T3-D22-W20-L150-2	22	2	20	150	30	1.4	SD..09T3..	TDA-044	BDA-26	TDA-039	LLT-10
NPDF-SD09T3-D25-C25-L150-2	25	2	25	150	94	1.4					
NPDF-SD09T3-D25-W25-L150-2	25	2	25	150	94	1.4					
NPDF-SD09T3-D28-C25-L150-2	28	2	25	150	30	1.4					
NPDF-SD09T3-D32-C32-L150-3	32	3	32	150	100	1.4					
NPDF-SD09T3-D32-W32-L150-3	32	3	32	150	90	1.4					
NPDF-SD09T3-D25-C25-L150-3	25	3	25	150	60	1.4			-	-	
NPDF-SD09T3-D32-C32-L150-4	32	4	25	150	60	1.4			-	-	

Portaherramientas de fresado - Placa EP..1003.. / YPHW1003.. / ZPMT1003..

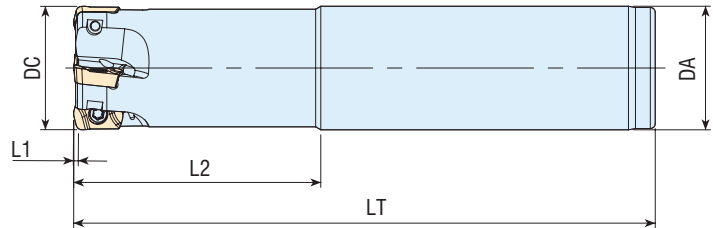

REFERENCIA	DC	Z	DA	LT	L2	L1	INSERTO	TORNILLO	LLAVE
NPDF-YP1003-D16-C15-L150-2	16	2	15	150	20	1	EP..1003..	TDA-013	LLT-8
NPDF-YP1003-D16-C15-L200-2	16	2	15	200	20	1	YPHW1003..		
NPDF-YP1003-D16-C16-L150-2	16	2	16	150	50	1	ZPMT1003..		
NPDF-YP1003-D17-C16-L150-2	17	2	16	150	20	1			
NPDF-YP1003-D17-C16-L200-2	17	2	16	200	20	1			
NPDF-YP1003-D20-C18-L150-3	20	3	18	150	25	1			
NPDF-YP1003-D20-C18-L200-3	20	3	18	200	25	1			
NPDF-YP1003-D20-C20-L150-3	20	3	20	150	50	1			
NPDF-YP1003-D21-C20-L150-3	21	3	20	150	20	1			
NPDF-YP1003-D21-C20-L150-3R	21	3	20	150	20	1			
NPDF-YP1003-D21-C20-L150-4	21	4	20	150	20	1			
NPDF-YP1003-D21-C20-L200-3	21	3	20	200	20	1			
NPDF-YP1003-D21-C20-L200-3	21	3	20	200	20	1			
NPDF-YP1003-D25-C20-L150-4	25	4	20	150	25	1			
NPDF-YP1003-D25-C20-L200-4	25	4	20	200	25	1			
NPDF-YP1003-D25-C25-L150-4	25	4	25	150	50	1			
NPDF-YP1003-D26-C25-L150-4	26	4	25	150	30	1			
NPDF-YP1003-D26-C25-L150-4	26	4	25	150	30	1			
NPDF-YP1003-D26-C25-L200-3	26	3	25	200	30	1			
NPDF-YP1003-D26-C25-L200-4	26	4	25	200	30	1			

Portaherramientas de fresado - Placa SPNW1004..

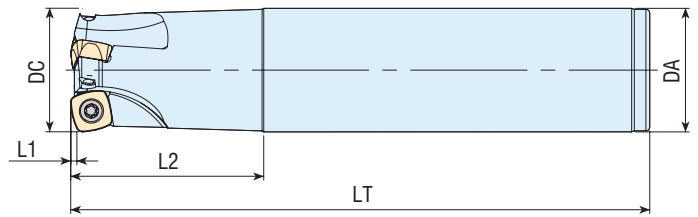

REFERENCIA	DC	Z	DA	LT	L2	L1	INSERTO	TORNILLO	LLAVE
NPDF-SP1004-D25-C25-L150-2	25	2	25	150	50	1.5	SPNW1004..	TDA-045	LLT-15
NPDF-SP1004-D32-C32-L150-3	32	3	32	150	50	1.5			

Portaherramientas de fresado - Placa YOHW0602..

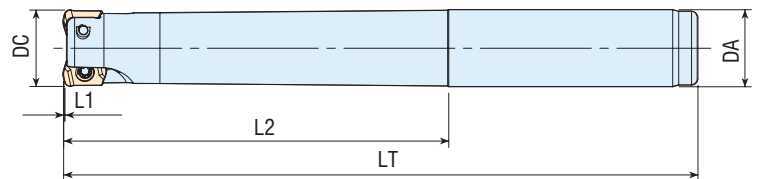

REFERENCIA	DC	Z	DA	LT	L2	L1	INSERTO	TORNILLO	LLAVE
NPDF-YO0602-D10-C09-L120-2	10	2	9	120	15	0.3	YOHW0602..	TDA-002	LLT-6
NPDF-YO0602-D10-C10-L080-2	10	2	10	80	20	0.3			
NPDF-YO0602-D10-C10-L120-2	10	2	10	120	60	0.3			
NPDF-YO0602-D10-C10-L120-2R	10	2	10	120	60	0.3			
NPDF-YO0602-D10-C10-L120-2R	10	2	10	120	60	0.3			
NPDF-YO0602-D12-C11-L120-2	12	2	11	120	15	0.3			
NPDF-YO0602-D12-C11-L120-2R	12	2	11	120	15	0.3			
NPDF-YO0602-D12-C11-L120-2R	12	2	11	120	15	0.3			
NPDF-YO0602-D12-C11-L120-3	12	3	11	120	15	0.3			
NPDF-YO0602-D12-C12-L080-2	12	2	12	80	20	0.3			
NPDF-YO0602-D12-C12-L080-3	12	3	12	80	20	0.3			
NPDF-YO0602-D12-C12-L120-2	12	2	12	120	60	0.3			
NPDF-YO0602-D12-C12-L120-2R	12	2	12	120	60	0.3			
NPDF-YO0602-D12-C12-L120-3	12	3	12	120	60	0.3			
NPDF-YO0602-D12-C12-L120-3R	12	3	12	120	60	0.3			

Portaherramientas de fresado - Placa WDMT..

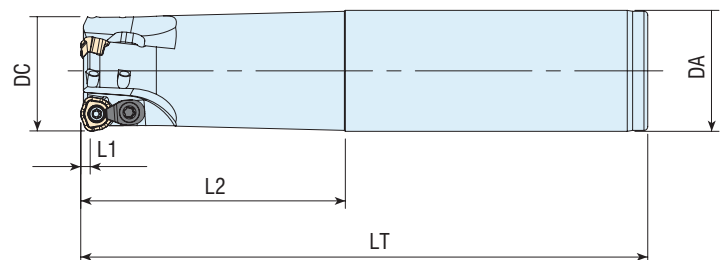

REFERENCIA	DC	Z	DA	LT	L2	L1	INSERTO	TORNILLO	BRIDA	TORNILLO BRIDA	LLAVE
NPDF-WD0603-D16-C16-L150-2	16	2	16	150	70	2	WDMT0603..	TDA-014	-	-	LLT-8
NPDF-WD0603-D20-C20-L150-3	20	3	20	150	70	2					
NPDF-WD0804-D25-C25-L150-2	25	2	25	150	70	1.5	WDMT0804..	TDA-032	BDA-26	TDA-032	LLT-10
NPDF-WD0804-D32-C32-L150-3	32	3	32	150	70	1.5					
NPDF-WD1205-D32-C32-L150-2	32	2	32	150	70	3	WDMT1205..	TDA-058	BDA-18	TDA-066	LLT-15

Portaherramientas de fresado - Placa WD.W0503.. / WD.W06T3..

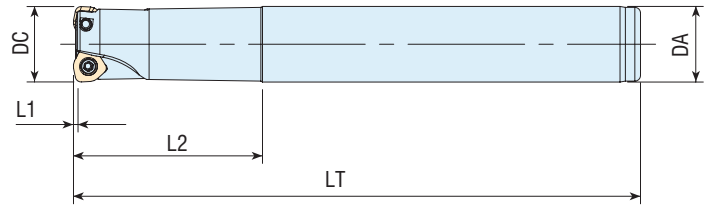

REFERENCIA	DC	Z	DA	LT	L2	L1	INSERTO	TORNILLO	BRIDA	TORNILLO BRIDA	LLAVE
NPDF-WD0503D-D20-C20-L150-2	20	2	20	150	50	1.25	WD.W0503..	TDA-031	-	-	LLT-10
NPDF-WD0503D-D21-C20-L150-2	21	2	20	150	30	1.25					
NPDF-WD06T3D-D26-C25-L200-2	26	2	25	200	30	1.5	WD.W06T3..	TDA-045	BDA-26	TDA-049	LLT-15
NPDF-WD06T3D-D33-C32-L200-3	33	3	32	200	32	1.5					

Portaherramientas de fresado - Placa WNMX..

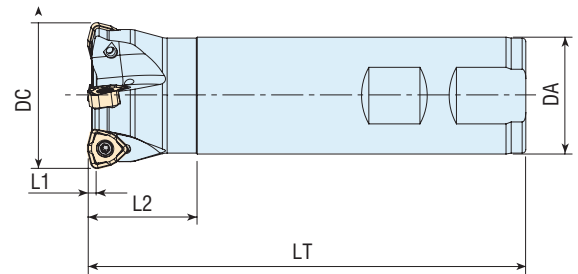

REFERENCIA	DC	Z	DA	LT	L2	L1	INSERTO	TORNILLO	LLAVE
NPDF-WN0603-D16-C16-L110-2R	16	2	16	110	30	1	WNMX0603..	TDA-014	LLT-8
NPDF-WN0603-D16-C16-L150-2R	16	2	16	150	70	1			
NPDF-WN0603-D17-C16-L150-2R	17	2	16	150	20	1			
NPDF-WN0603-D20-C20-L150-2R	20	2	20	150	70	1			
NPDF-WN0603-D20-C20-L200-2R	20	2	20	200	100	1			
NPDF-WN0603-D21-C20-L150-2R	21	2	20	150	20	1			
NPDF-WN09T3-D25-C25-L200-2	25	2	25	200	120	1.5			
NPDF-WN09T3-D30-W25-L120-3R	30	3	25	120	30	1.5			
NPDF-WN09T3-D32-W32-L120-3R	32	3	32	120	30	1.5			
NPDF-WN09T3-D32-W32-L200-3R	32	3	32	200	100	1.5			
NPDF-WN09T3-D35-W32-L200-4R	35	4	32	200	50	1.5			
NPDF-WN09T3-D40-W32-L120-4R	40	4	32	120	30	1.5			
NPDF-WN09T3-D40-C32-L200-4	40	4	32	200	30	1.5			
NPDF-WN1305-D32-C32-L150-2R	32	2	32	150	70	2	WNMX1305..	TDA-066	LLT-15
NPDF-WN1305-D32-C32-L200-2R	32	2	32	200	120	2			
NPDF-WN1305-D40-C32-L200-3R	40	3	32	200	30	2			

Portaherramientas de fresado - Placa WOMW04T2..

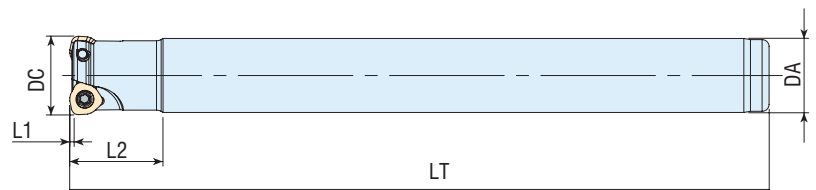

REFERENCIA	DC	Z	DA	LT	L2	L1	INSERTO	TORNILLO	LLAVE
NPDF-WO04T2D-D16-C16-L150-2	16	2	16	150	20	0.8	WOMW04T2..	TDA-014	LLT-8
NPDF-WO04T2D-D17-C16-L150-2	17	2	16	150	20	0.8			

Portaherramientas de Copiado - Placa BNM..

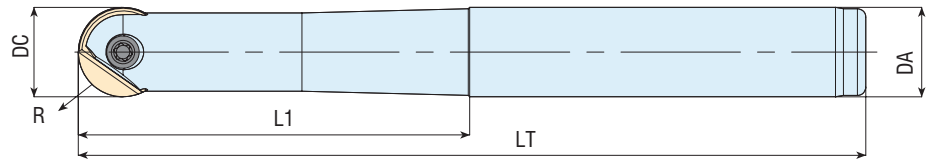

REFERENCIA	DC	R	DA	LT	L2	INSERTO	TORNILLO	LLAVE
NPDC-BNM12-D12-C12-L130	12	6	12	130	32	BNM120-S	TPA-008	LLT-10
NPDC-BNM16-D16-C16-L175	16	8	16	175	70	BNM160-S	TPA-009	LLT-15
NPDC-BNM16-D16-C16-L200	16	8	16	200	100			
NPDC-BNM20-D20-C20-L160	20	10	20	160	70	BNM200-S	TPA-005	LLT-20
NPDC-BNM20-D20-C20-L200	20	10	20	200	100			
NPDC-BNM20-D20-C20-L250	20	10	20	250	150			
NPDC-BNM25-D25-C25-L160	25	12.5	25	160	70	BNM250-S	TPA-006	LLT-20
NPDC-BNM25-D25-C25-L200	25	12.5	25	200	100			
NPDC-BNM25-D25-C25-L250	25	12.5	25	250	150			

Portaherramientas de Copiado - Placa ROHX..

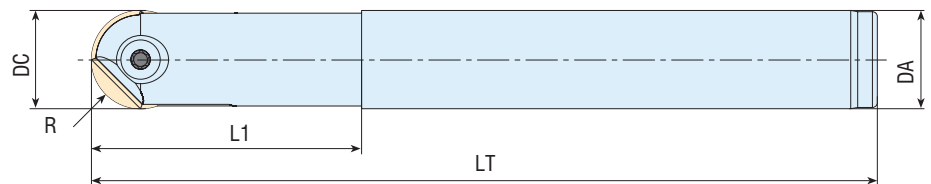

REFERENCIA	DC	R	DA	LT	L2	INSERTO	TORNILLO	LLAVE
NPDC-RO12-D12-C12-L120	12	6	12	120	35	ROHX 1203	TPA-002	LLT-15
NPDC-RO12-D12-C16-L160	12	6	16	160	50			
NPDC-RO16-D16-C16-L160	16	8	16	160	45	ROHX 1604	TPA-004	LLT-20
NPDC-RO16-D16-C16-L200	16	8	16	200	45			
NPDC-RO16-D16-C20-L200	16	8	20	200	65			
NPDC-RO20-D20-C20-L160	20	10	20	160	55	ROHX 2005	TPA-005	LLT-20
NPDC-RO20-D20-C20-L200	20	10	20	200	55			
NPDC-RO20-D20-C25-L220	20	10	25	220	80			

Portaherramientas de Copiado - Placa P3...

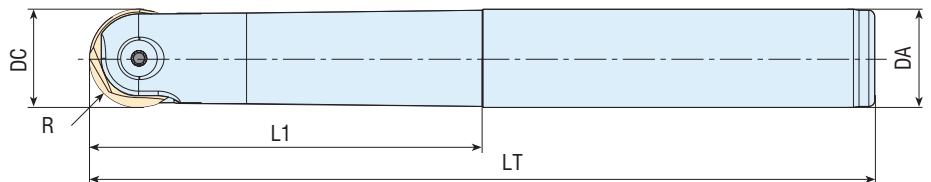

REFERENCIA	DC	R	DA	LT	L2	INSERTO	TORNILLO	LLAVE
NPDC-P3208-D08-C10-L110	8	4	10	110	25	P3208	TPA-001	LLT-8
NPDC-P3210-D10-C10-L130	10	5	10	130	30	P3210	TPA-002	LLT-15
NPDC-P3210-D10-C12-L130	10	5	12	130	30	P3210	TPA-002	LLT-15
NPDC-P3212-D12-C12-L130	12	6	12	130	32	P3212	TPA-003	LLT-20
NPDC-P3216-D16-C16-L175	16	8	16	175	75	P3216	TPA-004	LLT-20
NPDC-P3220-D20-C20-L200	20	10	20	200	100	P3220	TPA-005	LLT-20
NPDC-P3225-D25-C25-L200	25	12.5	25	200	100	P3225	TPA-006	LLT-20
NPDC-P3232-D32-C32-L200	32	16	32	200	100	P3232	TPA-007	LLA-4

Portaherramientas de Copiado - Placa XPHT...

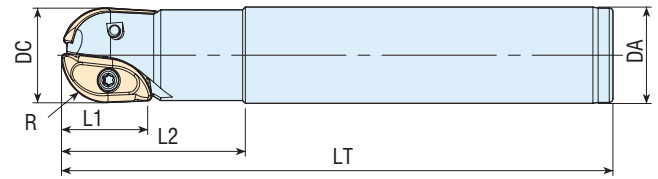

REFERENCIA	DC	R	DA	LT	L2	L1	INSERTO	TORNILLO	LLAVE
NPDC-XP16-D16-C16-L150	16	8	16	150	40	16	XPHT 16R0803	TDA-014	LLT-8
NPDC-XP20-D20-C20-L150	20	10	20	150	50	20	XPHT 20R10R3	TDA-043	LLT-10
NPDC-XP25-D25-C25-L150	25	12.5	25	150	50	25	XPHT 25R1204	TDA-064	LLT-15

Portaherramientas de Avellanado - Placa TB.. TC..

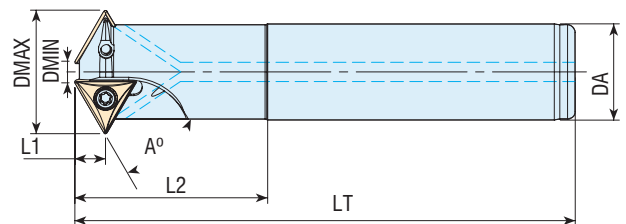

REFERENCIA	A°	Dmax	DA	Dmin	LT	L2	Z	L1	INSERTO	TORNILLO	LLAVE
NPDF60-TB0601-D13-C10-L150-2R	60	13	10	2.5	150	40	2	3.3	TBGT060102	TDA-006	LLT-6
NPDF60-TC0902-D20.5-C16-L150-2R	60	20.5	16	5.2	150	40	2	4.7	TC.T090202	TDA-008	80-T07
NPDF60-TC1102-D26-C20-L150-3R	60	26	20	8.3	150	50	3	5.4	TC.T110202	TDA-014	LLT-8
NPDF60-TC16T3-D32-C25-L150-2R	60	32	25	6.4	150	50	2	8	TC.T16T304	TDA-047	LLT-15
NPDF60-TC16T3-D40-C32-L250-3R	60	40	32	13.7	250	50	3	8	TC.T16T304	TDA-047	LLT-15

Portaherramientas de Fresado - Placa AP..1003.. / AP..1204..

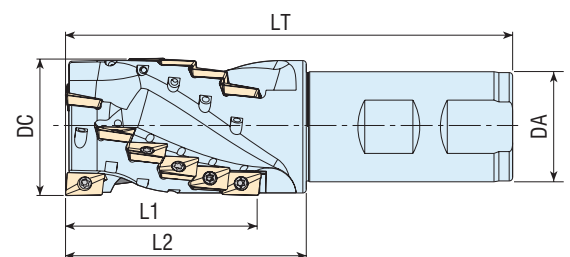

REFERENCIA	Z	DC	DA	L1	L2	LT	INSERTO	TORNILLO	LLAVE
NPDF90-AP10-D20-W20-L087-0204	4-2	20	20	28	37	87	AP..1003..	TDA-014	LLT-8
NPDF90-AP10-D20-W20-L087-0206	6-2	20	20	28	37	87			
NPDF90-AP10-D25-W25-L105-0208R	8-2	25	25	37	50	105			
NPDF90-AP10-D32-W32-L115-0315R	15-3	32	32	46	55	115			
NPDF90-AP10-D40-W32-L130-0318R	18-3	40	32	55	70	130			

REFERENCIA	Z	DC	DA	L1	L2	LT	INSERTO	TORNILLO	LLAVE
NPDF90-AP1204-D32-W32-L140-0212R	12-2	32	32	68	80	140	AP..1204..	TDA-044	LLT-10
NPDF90-AP1204-D40-W32-L160-0321R	21-3	40	32	79	100	160			

Plato de Fresado 42° - XDMW0806..

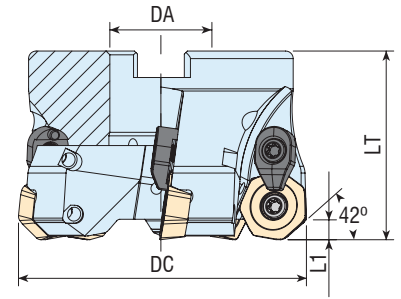

REFERENCIA	DC	Z	DA	LT	L1	INSERTO	Tornillo Placa	Brida Placa	Tornillo Brida	Llave
NPDF42C-XD0806-D063-E27-4R	63	4	27	50	12	XDMW0806..	TDA-079	BDA-30	TDA-079	LLT-20
NPDF42C-XD0806-D080-E27-5R	80	5	27	50	12					
NPDF42C-XD0806-D100-E32-6R	100	6	32	63	12					
NPDF42C-XD0806-D125-E40-7	125	7	40	63	12					
NPDF42C-XD0806-D160-E40-8	160	8	40	63	12					
NPDF42C-XD0806-D200-E60-9	200	9	60	63	12					

Plato de Fresado 43° - OD..0504..

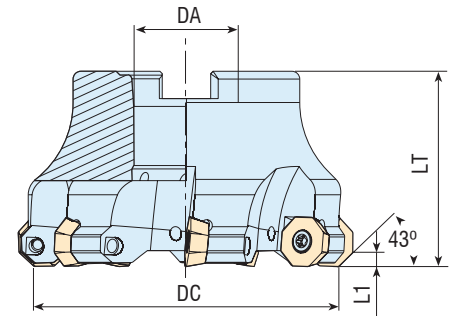

REFERENCIA	DC	Z	DA	LT	L1	INSERTO	Tornillo Placa	Brida Placa	Tornillo Brida	Llave
NPDF43-OD0504-D040-E16-4R	40	4	16	40	3.5	OD..0504..	TDA-049	-	-	LLT-15
NPDF43-OD0504-D050-E22-5R	50	5	22	40	3.5					
NPDF43-OD0504-D063-E22-6R	63	6	22	40	3.5					
NPDF43-OD0504-D080-E27-7R	80	7	27	50	3.5					
NPDF43-OD0504-D100-E32-8R	100	8	32	50	3.5					

Plato de Fresado 43° - OF..05T3..

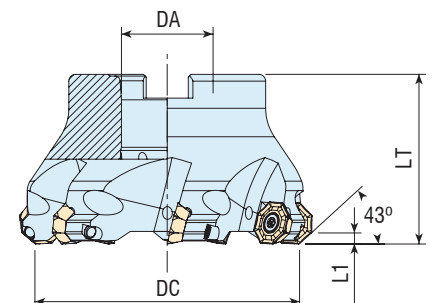

REFERENCIA	DC	Z	DA	LT	L1	INSERTO	Tornillo Placa	Brida Placa	Tornillo Brida	Llave
NPDF43-OF05T3-D050-E22-5R	50	5	22	40	3	OF..05T3..	TDA-064	-	-	LLT-15
NPDF43-OF05T3-D063-E22-6R	63	6	22	40	3		TDA-066	-	-	LLT-15
NPDF43-OF05T3-D080-E27-7R	80	7	27	50	3					
NPDF43-OF05T3-D125-E40-9	125	9	40	63	3					

Plato de Fresado 43° - OD..0605..

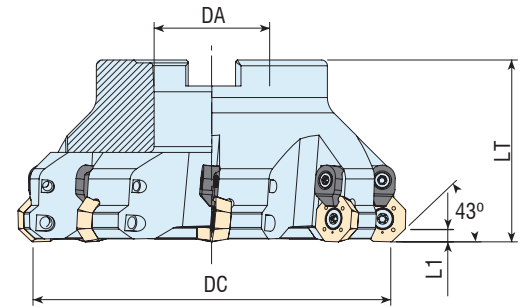

REFERENCIA	DC	Z	DA	LT	L1	INSERTO	Tornillo Placa	Brida Placa	Tornillo Brida	Llave
NPDF43C-OD0605-D080-E27-6R	80	6	27	50	4	OD..0605..	TDA-081	BDA-18	TDA-066	LLT-20
NPDF43C-OD0605-D100-E32-7R	100	7	32	50	4					
NPDF43C-OD0605-D125-E40-8	125	8	40	63	4					

Plato de Fresado 43° - ON..0604..

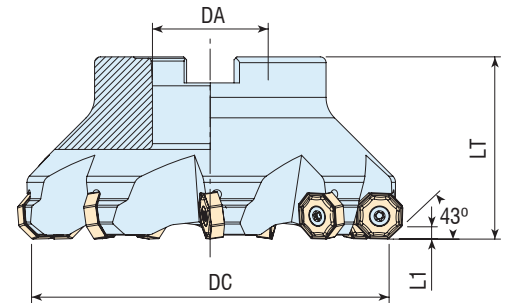
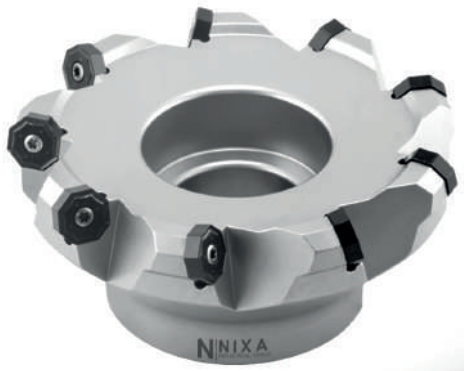

REFERENCIA	DC	Z	DA	LT	L1	INSERTO	Tornillo Placa	Brida Placa	Tornillo Brida	Llave
NPDF43-ON0604-D050-E22-5R	50	5	22	40	4	ON..0604..	TDA-066	-	-	LLT-15
NPDF43-ON0604-D063-E22-6R	63	6	22	40	4					
NPDF43-ON0604-D080-E27-7R	80	7	27	50	4					
NPDF43-ON0604-D100-E32-8R	100	8	32	50	4					
NPDF43-ON0604-D125-E40-9	125	9	40	63	4					

Plato de Fresado 44° - ONHX 0606....

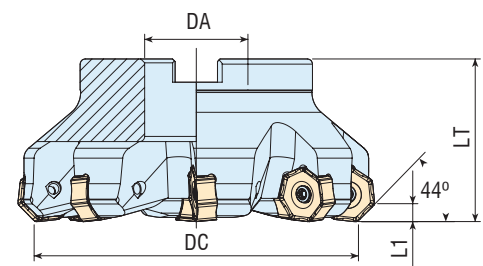

REFERENCIA	DC	Z	DA	LT	L1	INSERTO	Tornillo Placa	Brida Placa	Tornillo Brida	Llave
NPDF44-ON0606-D063-E22-6R	63	6	22	40	3.8	ONHX 0606..	TDA-079	-	-	LLT-15
NPDF44-ON0606-D080-E27-8R	80	8	27	50	3.8					
NPDF44-ON0606-D100-E32-10R	100	10	32	50	3.8					

Plato de Fresado 45° - HN..0905..

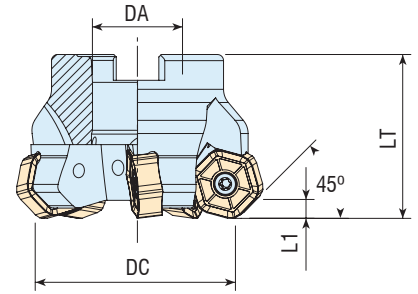
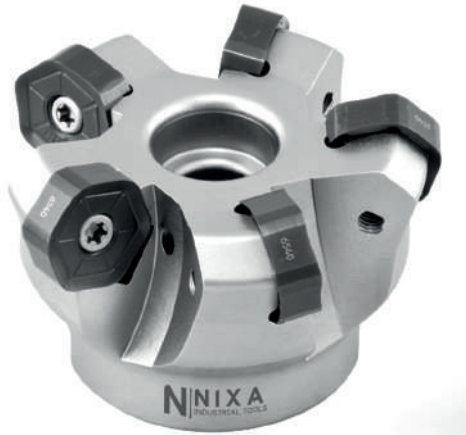

REFERENCIA	DC	Z	DA	LT	L1	INSERTO	Tornillo Placa	Llave
NPDF45-HN0905-D050-E22-5R	50	5	22	40	4.5	HN..0905..	TDA-066	LLT-15
NPDF45-HN0905-D063-E22-6R	63	6	22	40	4.5			
NPDF45-HN0905-D080-E27-7R	80	7	27	50	4.5			
NPDF45-HN0905-D125-E40-10	125	10	40	63	4.5			
NPDF45-HN0905-D160-E40-12	160	12	40	63	4.5			
NPDF45-HN0905-D200-E60-16	200	16	60	63	4.5			

Plato de Fresado 45° - NNMU2007..

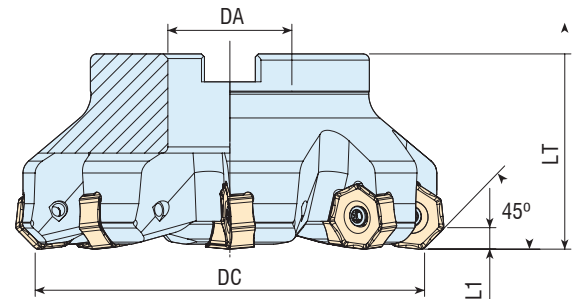

REFERENCIA	DC	Z	DA	LT	L1	INSERTO	Tornillo Placa	Brida Placa	Tornillo Brida	Llave
NPDF45-NN2007-D100-E32-7R	100	7	32	50	6	NNMU2007..	TDA-082	-	-	LLT-20
NPDF45-NN2007-D125-E40-8	125	8	40	63	6					
NPDF45-NN2007-D160-E40-10	160	10	50	63	6					

Plato de Fresado 45° - SAKU1706

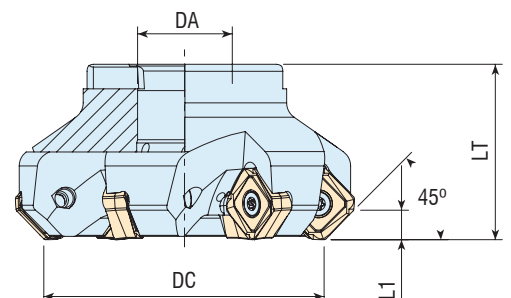

REFERENCIA	DC	Z	DA	LT	L1	INSERTO	Tornillo Placa	Llave
NPDF45-SA1706-D080-E27-6R	80	6	27	50	8.4	SAKU1706..	TDA-082	LLT-20
NPDF45-SA1706-D100-E32-7R	100	7	32	50	8.4			
NPDF45-SA1706-D125-E40-9	125	9	40	63	8.4			

Plato de Fresado 45° - SE..12T3.. / R245-12R3..

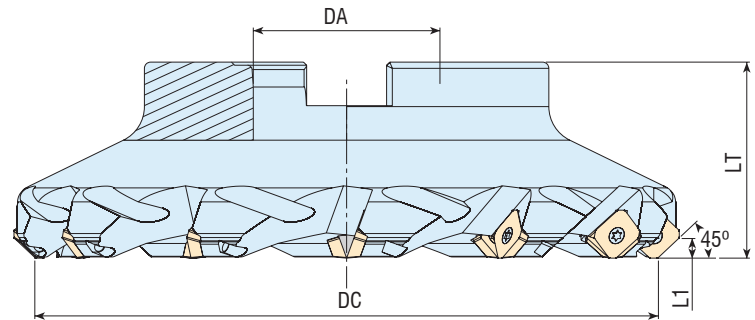

REFERENCIA	DC	Z	DA	LT	L1	INSERTO	Tornillo Placa	Brida Placa	Tornillo Brida	Llave
NPDF45-SE12-D050-E22-4R	50	4	22	40	6	SE..12T3..	TDA-049	-	-	LLT-15
NPDF45-SE12-D063-E22-5R	63	5	22	40	6	R245-12T3..				
NPDF45-SE12-D080-E27-6R	80	6	27	50	6					
NPDF45-SE12-D100-E32-7R	100	7	32	50	6					
NPDF45-SE12-D125-E40-8	125	8	40	63	6					
NPDF45-SE12-D160-E40-10	160	10	40	63	6					
NPDF45-SE12-D200-E60-12	200	12	60	63	6					

Plato de Fresado 45° - SEMT13T3..

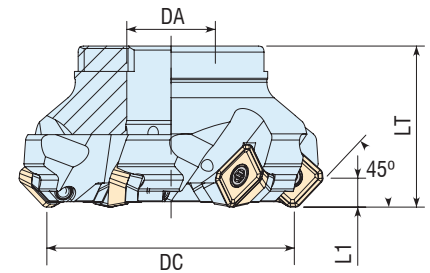

REFERENCIA	DC	Z	DA	LT	L1	INSERTO	Placa Base	Tornillo base	Tornillo placa	Llave
NPDF45-SE13-D050-E22-4R	50	4	22	40	6	SEMT13T3..	-	-	TDA-049	LLT-15
NPDF45-SE13-D063-E22-5R	63	5	22	40	6		-	-		
NPDF45-SE13-D080-E27-6R	80	6	27	50	6		-	-		
NPDF45B-SE13-D050-E22-5R	50	5	22	40	6	SEMT13T3	PB-025	TPB-015	TDA-050	LLT-15
NPDF45B-SE13-D063-E22-6R	63	6	22	40	6					
NPDF45B-SE13-D080-E27-8R	80	8	27	50	6					
NPDF45B-SE13-D100-E32-10R	100	10	32	50	6					
NPDF45B-SE13-D125-E40-12	125	12	40	63	6					

Plato de Fresado 45° - SE..14M4

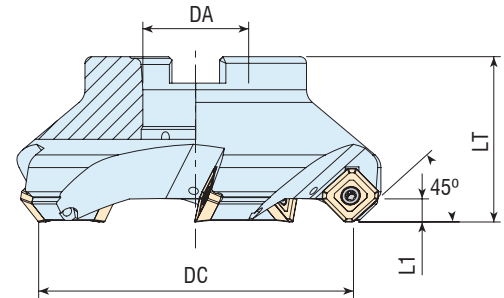

REFERENCIA	DC	Z	DA	LT	L1	INSERTO	Tornillo Placa	Llave
NPDF45-SE14M4-D063-E22-4R	63	4	22	40	7	SE..14M4..	TDA-049	LLT-15
NPDF45-SE14M4-D080-E27-5R	80	5	27	50	7			
NPDF45-SE14M4-D100-E32-5R	100	5	32	50	7			
NPDF45-SE14M4-D125-E40-6	125	6	40	63	7			
NPDF45-SE14M4-D160-E40-7	160	7	40	63	7			

Plato de Fresado 45° - SN..12

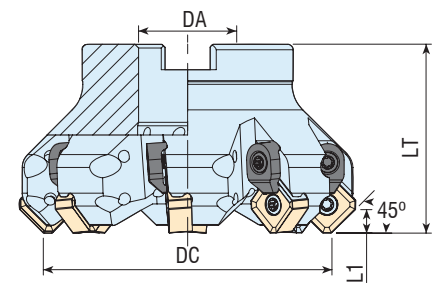

REFERENCIA	DC	Z	DA	LT	L1	INSERTO	Tornillo Placa	Brida Placa	Tornillo Brida	Llave
NPDF45C-SN12-D050-E22-4R	50	4	22	42	6	SN..12..	TDA-055	BDA-18	TDA-066	LLT-15
NPDF45C-SN12-D050-E22-5R	50	5	22	42	6					
NPDF45C-SN12-D063-E22-6R	63	6	22	42	6					
NPDF45C-SN12-D063-E22-7R	63	7	22	42	6					
NPDF45C-SN12-D080-E27-7R	80	7	27	52	6					
NPDF45C-SN12-D080-E27-8R	80	8	27	52	6					
NPDF45C-SN12-D100-E32-8R	100	8	32	52	6					
NPDF45C-SN12-D100-E32-10R	100	10	32	52	6					
NPDF45C-SN12-D125-E40-11	125	11	40	65	6					
NPDF45C-SN12-D160-E40-12	160	12	40	65	6					
NPDF45C-SN12-D200-E60-14	200	14	60	65	6					

Plato de Fresado 45° - SN..1206

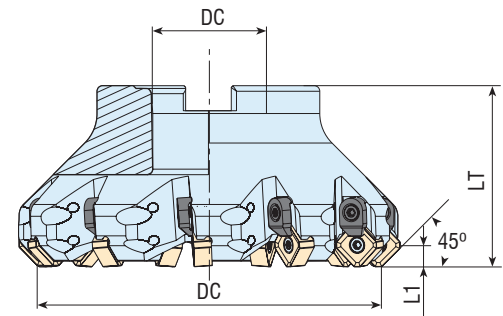

REFERENCIA	DC	Z	DA	LT	L1	INSERTO	Tornillo Placa	Brida Placa	Tornillo Brida	Llave
NPDF45C-SN1206-D050-E22-4R	50	4	22	42	6	SN..1206..	TDA-066	BDA-18	TDA-066	LLT-15
NPDF45C-SN1206-D050-E22-5R	50	5	22	42	6					
NPDF45C-SN1206-D063-E22-6R	63	6	22	42	6					
NPDF45C-SN1206-D063-E22-7R	63	7	22	42	6					
NPDF45C-SN1206-D080-E27-7R	80	7	27	52	6					
NPDF45C-SN1206-D080-E27-8R	80	8	27	52	6					
NPDF45C-SN1206-D100-E32-8R	100	8	32	52	6					
NPDF45C-SN1206-D100-E32-10R	100	10	32	52	6					
NPDF45C-SN1206-D125-E40-11	125	11	40	65	6					
NPDF45C-SN1206-D160-E40-12	160	12	40	65	6					
NPDF45C-SN1206-D200-E60-14	200	14	60	65	6					

Plato de Fresado 45° - SNEG1205..

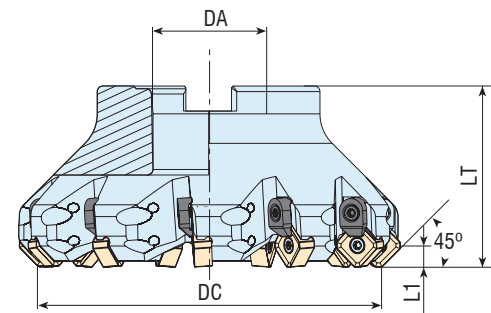

REFERENCIA	DC	Z	DA	LT	L1	INSERTO	Tornillo Placa	Brida Placa	Tornillo Brida	Llave
NPDF45C-SN12Z-D050-E22-5R	50	5	22	42	6	SN..1206..	TDA-066	BDA-18	TDA-066	LLT-15
NPDF45C-SN12Z-D063-E22-6R	63	6	22	42	6					
NPDF45C-SN12Z-D080-E27-7R	80	7	27	52	6					
NPDF45C-SN12Z-D100-E32-9R	100	9	32	52	6					
NPDF45C-SN12Z-D125-E40-11	125	11	40	65	6					
NPDF45C-SN12Z-D160-E40-12	160	12	60	65	6					
NPDF45C-SN12Z-D200-E60-14	200	14	60	65	6					

Plato de Fresado 45° - ON..0806..

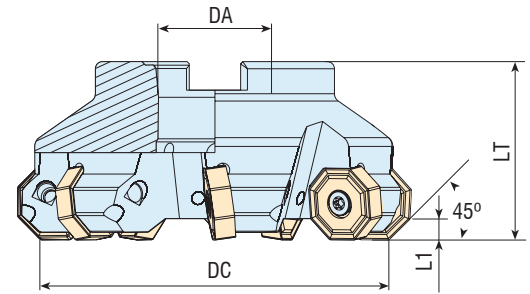

REFERENCIA	DC	Z	DA	LT	L1	INSERTO	Tornillo Placa	Llave
NPDF45-ON0806-D063-E22-5R	63	5	22	40	5.5	ON..0806..	TDA-082	LLT-20
NPDF45-ON0806-D063-E22-6R	63	6	22	40	5.5			
NPDF45-ON0806-D080-E27-6R	80	6	27	50	5.5			
NPDF45-ON0806-D080-E27-8R	80	8	27	50	5.5			
NPDF45-ON0806-D100-E32-7R	100	7	32	50	5.5			
NPDF45-ON0806-D100-E32-10R	100	10	32	50	5.5			
NPDF45-ON0806-D125-E40-8	125	8	40	63	5.5			
NPDF45-ON0806-D125-E40-12	125	12	40	63	5.5			
NPDF45-ON0806-D160-E40-10	160	10	40	63	5.5			
NPDF45-ON0806-D160-E40-14	160	14	40	63	5.5			
NPDF45-ON0806-D200-E60-12	200	12	60	63	5.5			
NPDF45-ON0806-D250-E60-14	250	14	60	63	5.5			
NPDF45-ON0806-D315-E60-16	315	16	60	63	5.5			

Plato de Fresado 45° - XNMU0906..

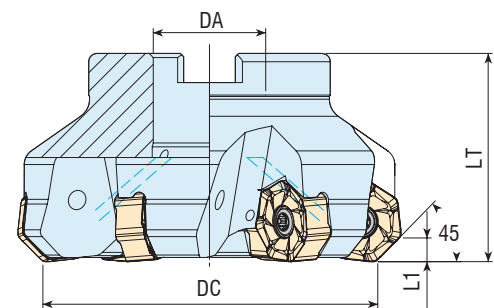

REFERENCIA	DC	Z	DA	LT	L1	INSERTO	Tornillo Placa	Llave
NPDF45-XN0906-D063-E22-6R	63	6	22	50	5	XNMU0906..	TDA-083	LLT-20
NPDF45-XN0906-D080-E27-6R	80	6	27	50	5			
NPDF45-XN0906-D100-E32-7R	100	7	32	55	5			
NPDF45-XN0906-D125-E40-8	125	8	40	63	5			

Plato de Fresado 66° - PNMU0905..

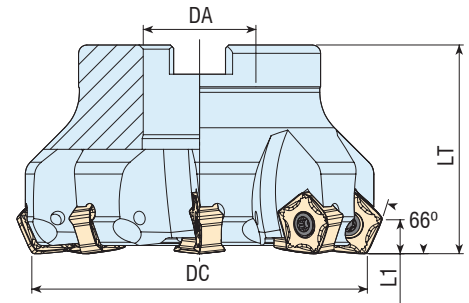

REFERENCIA	DC	Z	DA	LT	L1	INSERTO	Tornillo Placa	Llave
NPDF66-PN0905-D050-E22-5	50	5	22	40	8	PNMU0905..	TDA-066	LLT-15
NPDF66-PN0905-D063-E22-6	63	6	22	40	8			
NPDF66-PN0905-D080-E27-8	80	8	27	50	8			
NPDF66-PN0905-D100-E32-10	100	10	32	50	8			
NPDF66-PN0905-D125-E40-12	125	12	40	63	8			

Plato de Fresado 67° - PNEG1105..

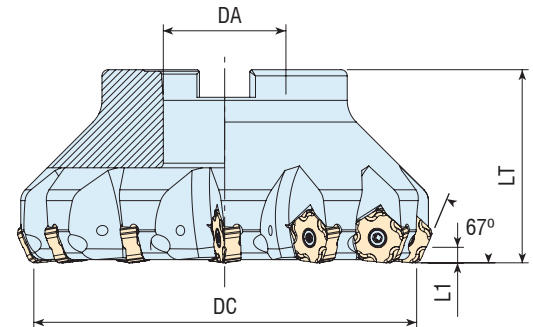

REFERENCIA	DC	Z	DA	LT	L1	INSERTO	Tornillo Placa	Llave
NPDF67-PN1105-D050-E22-5	50	5	22	50	5	PNEG1105..	TDA-066	LLT-15
NPDF67-PN1105-D063-E22-6	63	6	22	50	5			
NPDF67-PN1105-D080-E27-8	80	8	27	50	5			
NPDF67-PN1105-D100-E32-10	100	10	32	50	5			
NPDF67-PN1105-D125-E40-12	125	12	40	63	5			
NPDF67-PN1105-D160-E40-14	160	14	40	63	5			

Plato de Fresado 75° - AP..1604..

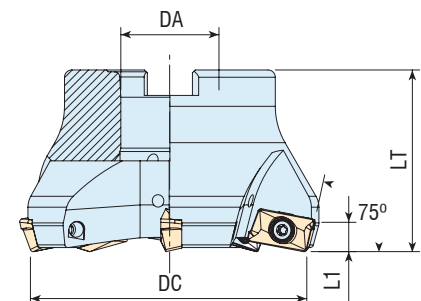

REFERENCIA	DC	Z	DA	LT	L1	INSERTO	Tornillo Placa	Llave
NPDF75-AP16-D063-E22-4R	63	4	22	40	6	AP..1604..	TDA-066	LLT-15
NPDF75-AP16-D080-E27-5R	80	5	27	50	6			
NPDF75-AP16-D100-E32-6R	100	6	32	50	6			
NPDF75-AP16-D125-E40-7	125	7	40	63	6			

Plato de Fresado 75° - XOMX1204..

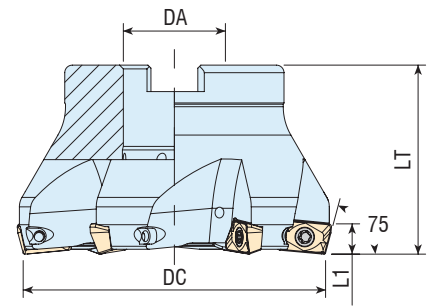

REFERENCIA	DC	Z	DA	LT	L1	INSERTO	Tornillo Placa	Llave
NPDF75-XO12-D050-E22-4R	50	4	22	40	-	XOMX1204..	TDA-044	LLT-10
NPDF75-XO12-D063-E22-5R	63	5	27	40	-			
NPDF75-XO12-D080-E27-6R	80	6	27	50	-			

Plato de Fresado 88° - SNMU1305..

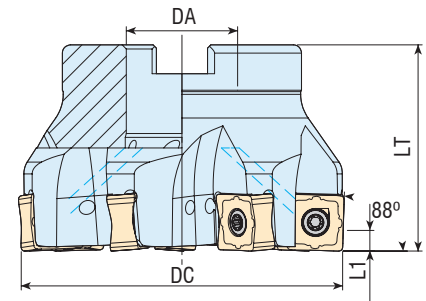

REFERENCIA	DC	Z	DA	LT	L1	INSERTO	Tornillo Placa	Llave
NPDF88-SN1305-D050-E22-4	50	4	22	40	5	SNMU1305..	TDA-066	LLT-15
NPDF88-SN1305-D050-E22-5	50	5	22	40	5			
NPDF88-SN1305-D063-E22-5	63	5	22	40	5			
NPDF88-SN1305-D063-E22-7	63	7	22	40	5			
NPDF88-SN1305-D080-E27-6	80	6	27	50	5			
NPDF88-SN1305-D080-E27-9	80	9	27	50	5			
NPDF88-SN1305-D100-E32-7	100	7	32	50	5			
NPDF88-SN1305-D100-E32-11	100	11	32	50	5			
NPDF88-SN1305-D125-E40-13	125	13	40	63	5			

Plato de Fresado 88° - SNGX1306..

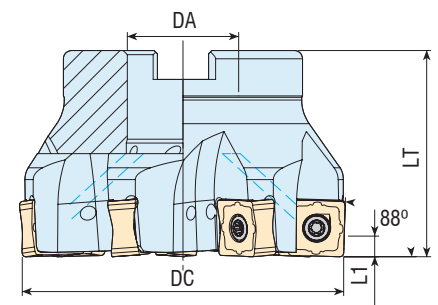

REFERENCIA	DC	Z	DA	LT	L1	INSERTO	Tornillo Placa	Llave
NPDF88-SN1306-D050-E22-5R	50	5	22	40	5	SNGX1306..	TDA-056	LLT-15
NPDF88-SN1306-D063-E22-6R	63	6	22	40	5			
NPDF88-SN1306-D080-E27-7R	80	7	27	50	5			

Plato de Fresado 88° - SN..1206..

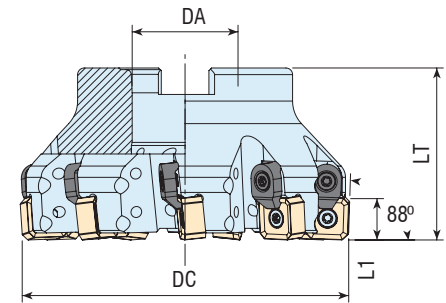

REFERENCIA	DC	Z	DA	LT	L1	INSERTO	Tornillo Placa	Brida Placa	Tornillo Brida	Llave
NPDF88C-SN1206-D050-E22-5R	50	5	22	40	11.5	SN..1206..	TDA-071	BDA-18	TDA-066	LLT-15
NPDF88C-SN1206-D063-E22-6R	63	6	22	40	11.5					
NPDF88C-SN1206-D080-E27-7R	80	7	27	50	11.5					
NPDF88C-SN1206-D100-E32-9R	100	9	32	52	11.5					

Plato de Fresado 88° - SN..12..

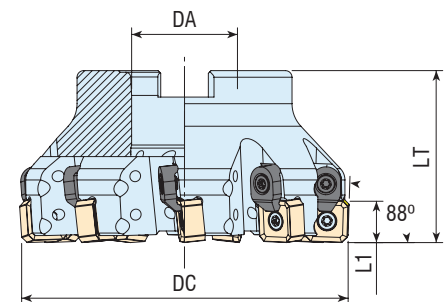

REFERENCIA	DC	Z	DA	LT	L1	INSERTO	Tornillo Placa	Brida Placa	Tornillo Brida	Llave
NPDF88C-SN12-D050-E22-5R	50	5	22	40	11.5	SN..12..	TDA-055	BDA-18	TDA-066	LLT-15
NPDF88C-SN12-D063-E22-6R	63	6	22	40	11.5					
NPDF88C-SN12-D080-E27-7R	80	7	27	50	11.5					
NPDF88C-SN12-D100-E32-9R	100	9	32	52	11.5					

Plato de Fresado 88° - SNEG1205..

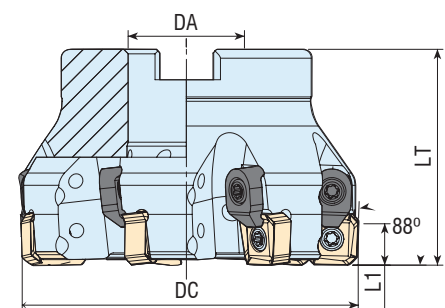

REFERENCIA	DC	Z	DA	LT	L1	INSERTO	Tornillo Placa	Brida Placa	Tornillo Brida	Llave
NPDF88C-SN12Z-D063-E22-6R	63	6	22	40	11.5	SNEG1205..	TDA-066	BDA-18	TDA-066	LLT-15
NPDF88C-SN12Z-D080-E27-7R	80	7	27	50	11.5					

Plato de Fresado 89° - SNMU1305 / OXMT0507

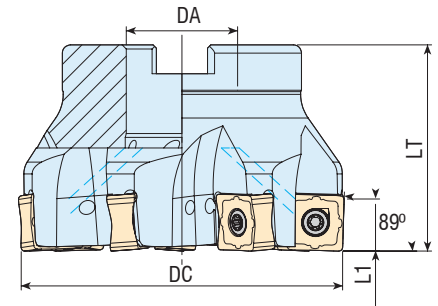

REFERENCIA	DC	Z	DA	LT	L1	INSERTO	Tornillo Placa	Llave
NPDF89-SN1305I-D040-E16-4R	40	4	16	40	10	SNMU1305..	TDA-055	LLT-15
NPDF89-SN1305I-D050-E22-5R	50	5	22	40	10	SNMG1305..		
NPDF89-SN1305I-D063-E22-6R	63	6	22	40	10	OXMT0507..		
NPDF89-SN1305I-D063-E22-7R	63	7	22	40	10			
NPDF89-SN1305I-D080-E27-8R	80	8	27	50	10			
NPDF89-SN1305I-D100-E32-10R	100	10	32	50	10			

Plato de Fresado 90° - ADMT10T3..

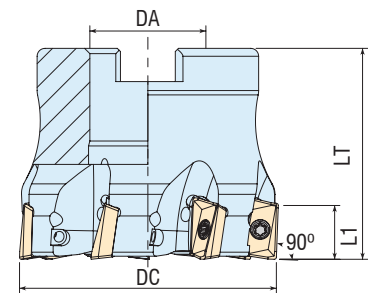

REFERENCIA	DC	Z	DA	LT	L1	INSERTO	Tornillo Placa	Llave
NPDF90-AD10T3-D040-E16-6R	40	6	16	40	10	ADMT10T3..	TDA-014	LLT-8
NPDF90-AD10T3-D050-E22-7R	50	7	22	40	10			

Plato de Fresado 90° - AD..1505.

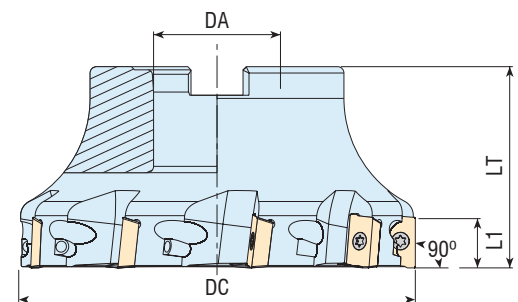
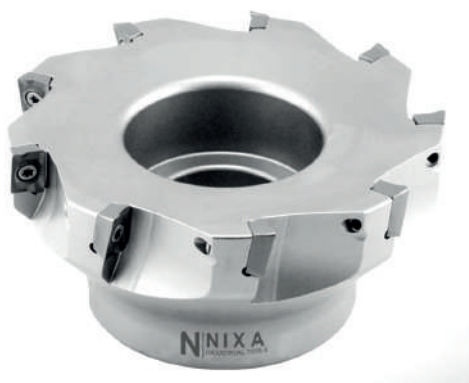

REFERENCIA	DC	Z	DA	LT	L1	INSERTO	Tornillo Placa	Llave
NPDF90-AD1505-D040-E16-4R	40	4	16	40	14.3	AD..1505..	TDA-066	LLT-15
NPDF90-AD1505-D050-E22-5R	50	5	22	40	14.3			
NPDF90-AD1505-D063-E22-6R	63	6	22	40	14.3			
NPDF90-AD1505-D080-E27-7R	80	7	27	50	14.3			
NPDF90-AD1505-D100-E32-8R	100	8	32	50	14.3			
NPDF90-AD1505-D125-E40-9	125	9	40	63	14.3			

Plato de Fresado 90° - AD..150508

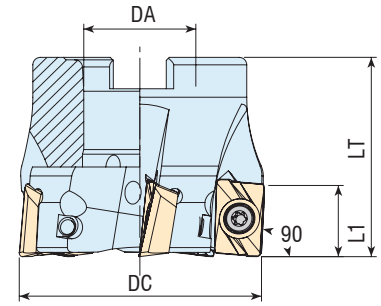

REFERENCIA	DC	Z	DA	LT	L1	INSERTO	Tornillo Placa	Llave
NPDF90-AD1505D-D050-E22-5R	50	5	22	40	14.3	ADKT150508	TDA-066	LLT-15
NPDF90-AD1505D-D063-E27-6R	63	6	27	50	14.3			
NPDF90-AD1505D-D080-E27-8R	80	8	27	50	14.3			
NPDF90-AD1505D-D100-E32-8R	100	8	32	50	14.3			
NPDF90-AD1505D-D125-E40-9	125	9	40	63	14.3			

Plato de Fresado 90° - ANGX1105.. / ANGX1506..

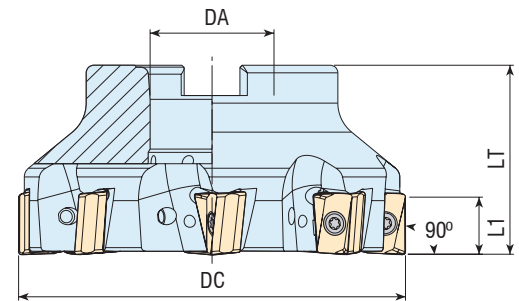

REFERENCIA	DC	Z	DA	LT	L1	INSERTO	Tornillo Placa	Llave
NPDF90-AN11-D040-E16-4R	40	4	16	40	11	ANGX1105..	TDA-032	LLT-10
NPDF90-AN1506-D050-E22-4R	50	4	22	40	14.5	ANGX1506..	TDA-067	LLT-15
NPDF90-AN1506-D063-E22-5R	63	5	22	40	14.5			
NPDF90-AN1506-D080-E27-6R	80	6	27	50	14.5			
NPDF90-AN1506-D100-E32-8R	100	8	32	50	14.5			
NPDF90-AN1506-D125-E40-9	125	9	40	63	14.5			
NPDF90-AN1506-D160-E40-10	160	10	40	63	14.5			

Plato de Fresado 90° - AN.X1607..

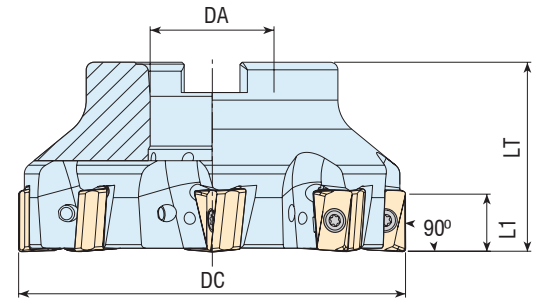

REFERENCIA	DC	Z	DA	LT	L1	INSERTO	Tornillo Placa	Llave
NPDF90-AN1607-D050-E22-4R	50	4	22	40	15	AN.X1607..	TDA-066	LLT-15
NPDF90-AN1607-D063-E22-6R	63	6	22	40	15			
NPDF90-AN1607-D080-E27-7R	80	7	27	50	15			
NPDF90-AN1607-D100-E32-8R	100	8	32	50	15			
NPDF90-AN1607-D125-E40-10	125	10	40	63	15			

Plato de Fresado 90° - ANKX1205..

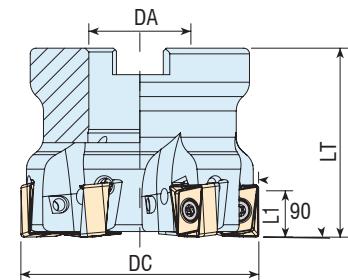

REFERENCIA	DC	Z	DA	LT	L1	INSERTO	Tornillo Placa	Llave
NPDF90-AN12-D040-E16-4R	40	4	16	40	12	ANKX1205..	TDA-067	LLT-15
NPDF90-AN12-D050-E22-5R	50	5	22	40	12			
NPDF90-AN12-D063-E27-6R	63	6	27	50	12			

Plato de Fresado 90° - ANKX1207 / ANKX1607

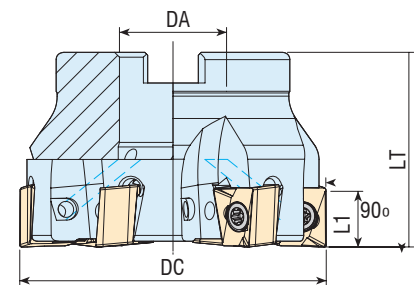

REFERENCIA	DC	Z	DA	LT	L1	INSERTO	Tornillo Placa	Llave
NPDF90-AN1207-D040-E16-4R	40	4	16	40	10	ANKX1207..	TDA-066	LLT-15
NPDF90-AN1207-D050-E22-5R	50	5	22	40	10			
NPDF90-AN1207-D063-E22-6R	63	6	22	40	10			
NPDF90-AN1607X-D050-E22-4R	50	4	22	40	15	ANKX1607..	TDA-066	LLT-15
NPDF90-AN1607X-D063-E22-6R	63	6	22	40	15			
NPDF90-AN1607X-D080-E27-7R	80	7	27	50	15			

Plato de Fresado 90° - AO..1236 / AO..1848

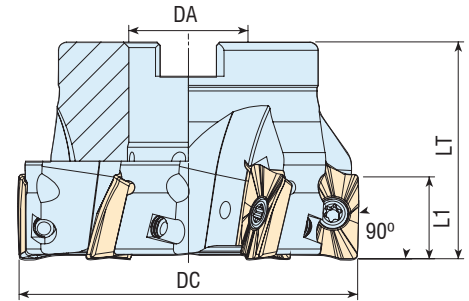

REFERENCIA	DC	Z	DA	LT	L1	INSERTO	Tornillo Placa	Llave
NPDF90-AO1236-D050-E22-5R	50	5	22	40	10	AO..1236..	TDA-014	LLT-8
NPDF90-AO1848-D050-E22-5R	50	5	22	40	15	AO..1848..	TDA-066	LLT-15
NPDF90-AO1848-D063-E22-6R	63	6	22	40	15			

Plato de Fresado 90° - AP..1003 / AP..1604..

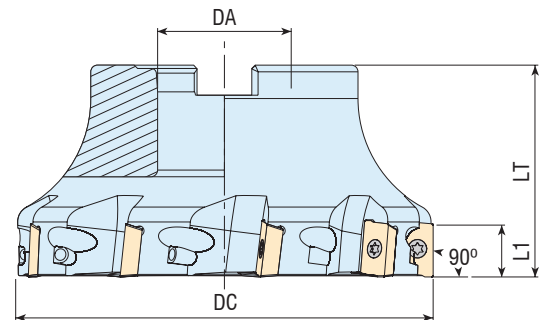

REFERENCIA	DC	Z	DA	LT	L1	INSERTO	Tornillo Placa	Llave
NPDF90-AP10-D040-E16-5R	40	5	16	40	10	AP..1003..	TDA-014	LLT-8
NPDF90-AP10-D050-E22-6R	50	6	22	40	10			
NPDF90-AP10-D063-E22-7R	63	7	22	40	10			
NPDF90-AP10-D080-E27-8R	80	8	27	50	10			
NPDF90-AP10-D100-E32-9R	100	9	32	50	10			
NPDF90-AP16-D040-E16-4R	40	4	16	40	16	AP..1604..	TDA-066	LLT-15
NPDF90-AP16-D050-E22-5R	50	5	22	40	16			
NPDF90-AP16-D052-E22-5R	52	5	22	40	16			
NPDF90-AP16-D063-E22-6R	63	6	22	40	16			
NPDF90-AP16-D080-E27-7R	80	7	27	50	16			
NPDF90-AP16-D100-E32-8R	100	8	32	50	16			
NPDF90-AP16-D125-E40-9	125	9	40	63	16			
NPDF90-AP16-D160-E40-10	160	10	40	63	16			
NPDF90-AP16-D200-E60-12	200	12	60	63	16			

Plato de Fresado 90° - AP..1705..

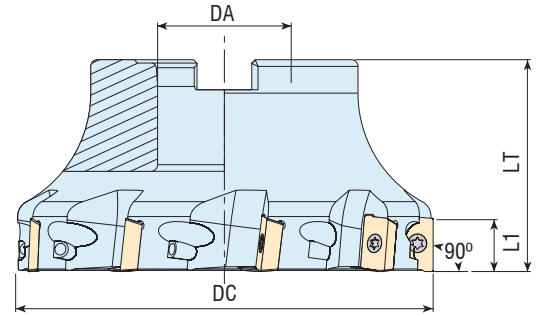

REFERENCIA	DC	Z	DA	LT	L1	INSERTO	Tornillo Placa	Llave
NPDF90-AP1705-D050-E22-5R	50	5	22	40	16	AP..1705..	TDA-066	LLT-15
NPDF90-AP1705-D063-E22-6R	63	6	22	40	16			
NPDF90-AP1705-D080-E27-7R	80	7	27	50	16			
NPDF90-AP1705-D100-E32-8R	100	8	32	50	16			

Plato de Fresado 90° - AX.T1235.. / AX.T1705..

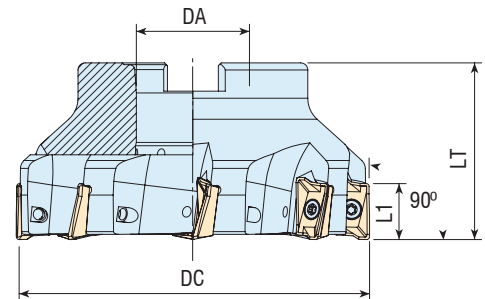

REFERENCIA	DC	Z	DA	LT	L1	INSERTO	Tornillo Placa	Llave
NPDF90-AX1235-D040-E16-6R	40	6	16	40	10	AX.T1235..	TDA-028	LLT-8
NPDF90-AX1235-D050-E22-7R	50	7	22	40	10			
NPDF90-AX1235-D063-E22-8R	63	8	22	40	10			
NPDF90-AX1235-D080-E27-10R	80	10	27	50	10			
NPDF90-AX1705-D040-E16-4R	40	4	16	40	14	AX.T1705..	TDA-066	LLT-15
NPDF90-AX1705-D050-E22-5R	50	5	22	40	14			
NPDF90-AX1705-D063-E22-6R	63	6	22	40	14			
NPDF90-AX1705-D080-E27-7R	80	7	27	50	14			
NPDF90-AX1705-D100-E32-8R	100	8	32	50	14			

Plato de Fresado 90° - LNMT1506..

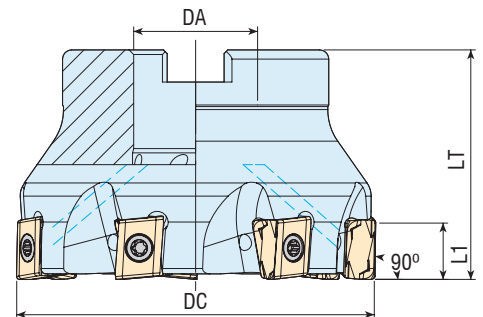

REFERENCIA	DC	Z	DA	LT	L1	INSERTO	Tornillo Placa	Llave
NPDF90-LN1506X-D063-E22-6	63	6	22	40	7	LNMT1506..	TDA-062	LLT-15
NPDF90-LN1506X-D080-E27-7	80	7	27	50	7			
NPDF90-LN1506X-D100-E32-8	100	8	32	50	7			

Plato de Fresado 90° - BDMT11T3.. / BDMT1704..

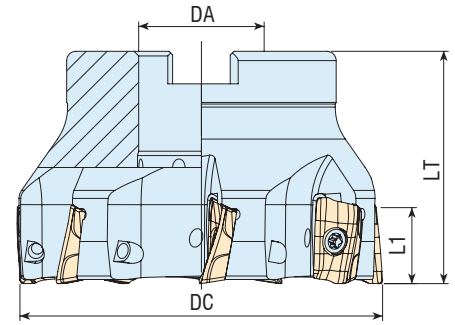

REFERENCIA	DC	Z	DA	LT	L1	INSERTO	Tornillo Placa	Llave
NPDF90-BD11T3-D040-E16-4R	40	4	16	40	10	BDMT11T3..	TDA-028	LLT-8
NPDF90-BD11T3-D040-E16-5R	40	5	16	40	10			
NPDF90-BD11T3-D050-E22-5R	50	5	22	40	10			
NPDF90-BD11T3-D063-E22-6R	63	6	22	40	10			
NPDF90-BD1704-D050-E22-4R	50	4	22	40	15.7	BDMT1704..	TDA-066	LLT-15
NPDF90-BD1704-D050-E22-5R	50	5	22	40	15.7			
NPDF90-BD1704-D063-E22-6R	63	6	22	40	15.7			
NPDF90-BD1704-D080-E27-6R	80	6	27	50	15.7			
NPDF90-BD1704-D080-E27-7R	80	7	27	50	15.7			
NPDF90-BD1704-D100-E32-7R	100	7	32	50	15.7			

Plato de Fresado 90° - LN..

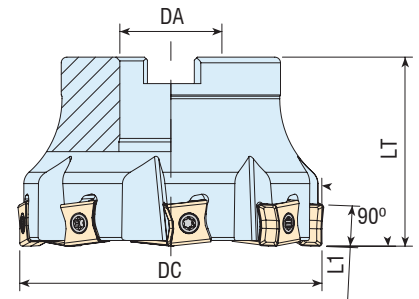

REFERENCIA	DC	Z	DA	LT	L1	INSERTO	Tornillo Placa	Llave
NPDF90-LN1106-D050-E22-5	50	5	22	40	10	LNMT1106..	TDA-049	LLT-15
NPDF90-LN1106-D063-E22-6	63	6	22	40	10			
NPDF90-LN1106-D080-E27-8	80	8	27	50	10			
NPDF90-LN1106-D100-E32-9	100	9	32	50	10			
NPDF90-LN1106-D125-E40-10	125	10	40	63	10			
NPDF90-LN1306-D040-E16-4R	40	4	16	40	12.5	T490-LNMT1306	TDA-066	LLT-15
NPDF90-LN1306-D050-E22-5R	50	5	22	40	12.5			
NPDF90-LN1306-D063-E22-6R	63	6	22	40	12.5			
NPDF90-LN1306-D080-E27-7R	80	7	27	50	12.5			
NPDF90-LN1306-D100-E32-8R	100	8	32	50	12.5			
NPDF90-LN1506-D040-E16-4	40	4	16	40	14			
NPDF90-LN1506-D050-E22-5	50	5	22	40	14			
NPDF90-LN1506-D063-E22-6	63	6	22	40	14			
NPDF90-LN1506-D080-E27-7	80	7	27	50	14			
NPDF90-LN1607-D050-E22-3R	50	3	22	40	16	T490-LNHT1607	TDA-087	LLT-20
NPDF90-LN1607-D063-E22-4R	63	4	22	40	16			
NPDF90-LN1607-D080-E27-5R	80	5	27	50	16			
NPDF90-LN1607-D100-E32-6R	100	6	32	50	16			

Plato de Fresado 90° - LNHU1306..

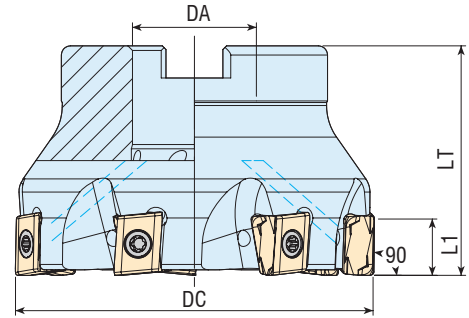

REFERENCIA	DC	Z	DA	LT	L1	INSERTO	Tornillo Placa	Llave
NPDF90-LN1306W-D050-E22-5R	50	5	22	40	12	LNHU1306..	TDA-068	LLT-15
NPDF90-LN1306W-D063-E22-6R	63	6	22	40	12			
NPDF90-LN1306W-D080-E27-7R	80	7	27	50	12			

Plato de Fresado 90° - LNGX1307..

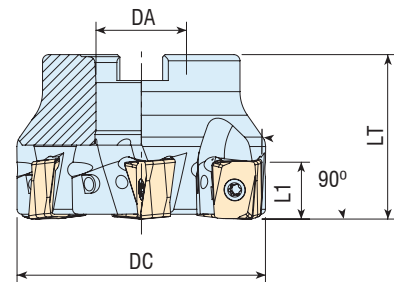

REFERENCIA	DC	Z	DA	LT	L1	INSERTO	Tornillo Placa	Llave
NPDF90-LN1307-D050-E22-4R	50	4	22	40	13	LNGX1307..	TDA-057	LLT-15
NPDF90-LN1307-D063-E22-6R	63	6	22	40	13			
NPDF90-LN1307-D080-E27-7R	80	7	27	50	13			
NPDF90-LN1307-D100-E32-8R	100	8	32	50	13			

Plato de Fresado 90° - LNKT1506..

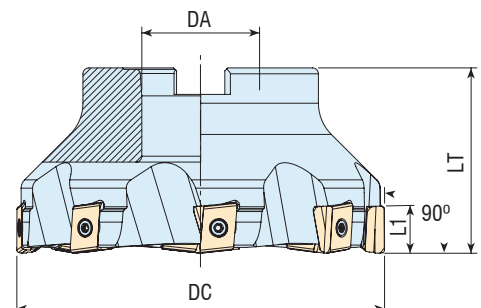

REFERENCIA	DC	Z	DA	LT	L1	INSERTO	Tornillo Placa	Llave
NPDF90-LN15Z-D050-E22-4	50	4	22	40	15	LNKT1506..	TDA-066	80-0T15
NPDF90-LN15Z-D063-E22-5	63	5	22	40	15			
NPDF90-LN15Z-D080-E27-6	80	6	27	50	15			
NPDF90-LN15Z-D100-E32-7	100	7	32	50	15			
NPDF90-LN15Z-D125-E40-8	125	8	40	63	15			

Plato de Fresado 90° - LOEX0804..

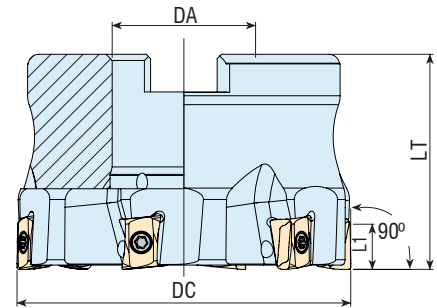

REFERENCIA	DC	Z	DA	LT	L1	INSERTO	Tornillo Placa	Llave
NPDF90-LO08-D040-E16-6R	40	6	16	40	2	LOEX0804..	TDA-015	LLT-8
NPDF90-LO08-D050-E22-7R	50	7	22	40	2			
NPDF90-LO08-D063-E27-6R	63	6	27	40	2			

Plato de Fresado 90° - LOGU1207..

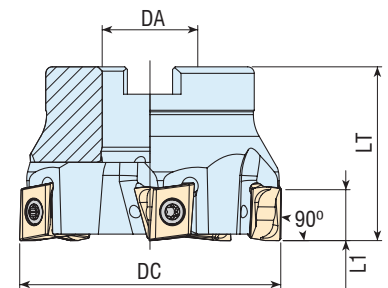

REFERENCIA	DC	Z	DA	LT	L1	INSERTO	Tornillo Placa	Llave
NPDF90-LO1207-D040-E16-4R	40	4	16	40	11	LOGU1207..	TDA-062	LLT-15
NPDF90-LO1207-D050-E22-5R	50	5	22	40	11			
NPDF90-LO1207-D063-E22-5R	63	5	22	40	11			

Plato de Fresado 90° - LNGU15T6..

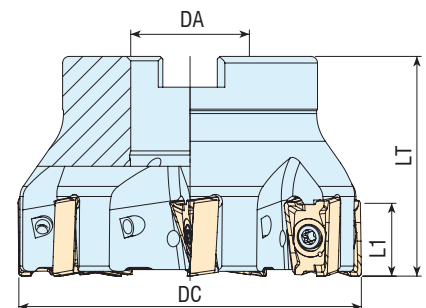

REFERENCIA	DC	Z	DA	LT	L1	INSERTO	Tornillo Placa	Llave
NPDF90-LN15T6-D050-E22-5R	50	5	22	40	15.5	LNGU15T6..	TDA-067	LLT-15
NPDF90-LN15T6-D063-E22-6R	63	6	22	40	15.5			
NPDF90-LN15T6-D080-E27-7R	80	7	27	50	15.5			

Plato de Fresado 90° - R290-12T3..

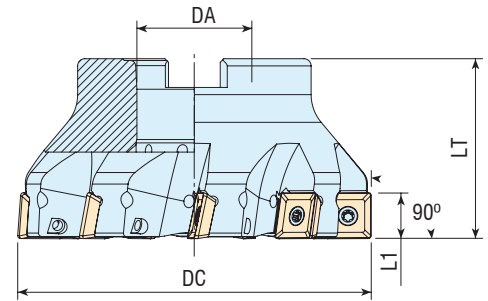

REFERENCIA	DC	Z	DA	LT	L1	INSERTO	Tornillo Placa	Llave
NPDF90-R290.12-D050-E22-4R	50	4	22	40	10.7	R290-12T3..	TDA-049	LLT-15
NPDF90-R290.12-D063-E22-5R	63	5	22	40	10.7			
NPDF90-R290.12-D080-E27-7R	80	7	27	50	10.7			
NPDF90-R290.12-D100-E32-9R	100	9	32	50	10.7			
NPDF90-R290.12-D125-E40-11	125	11	40	6	10.7			

Plato de Fresado 90° - R390...

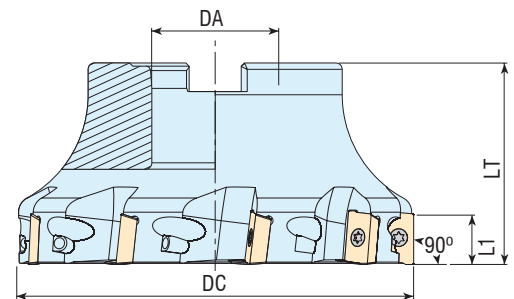

REFERENCIA	DC	Z	DA	LT	L1	INSERTO	Tornillo Placa	Llave
NPDF90-R390.11-D040-E16-5R	40	5	16	40	10	R390-11T3..	TDA-014	LLT-8
NPDF90-R390.11-D050-E22-6R	50	6	22	40	10			
NPDF90-R390.11-D063-E22-7R	63	7	22	40	10			
NPDF90-R390.11-D080-E27-9R	80	9	27	50	10			
NPDF90-R390.17-D040-E16-4R	40	4	16	40	15.4	R390-1704..	TDA-049	LLT-15
NPDF90-R390.17-D050-E22-5R	50	5	22	40	15.4			
NPDF90-R390.17-D063-E22-6R	63	6	22	40	15.4			
NPDF90-R390.17-D080-E27-7R	80	7	27	50	15.4			
NPDF90-R390.17-D100-E32-8R	100	8	32	50	15.4			
NPDF90-R390.17-D125-E40-9	125	9	40	63	15.4			
NPDF90-R390.18-D050-E22-4R	50	4	22	40	15.4	R390-1806..	TDA-066	LLT-15
NPDF90-R390.18-D063-E22-5R	63	5	22	40	15.4			
NPDF90-R390.18-D080-E27-6R	80	6	27	50	15.4			
NPDF90-R390.18-D100-E32-7R	100	7	32	50	15.4			
NPDF90-R390.18-D125-E40-8	125	8	40	63	15.4			

Plato de Fresado 90° - 490R-08T3.. / 490R-1404..

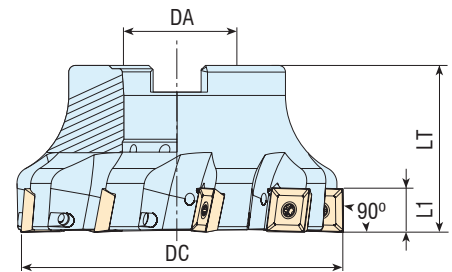

REFERENCIA	DC	Z	DA	LT	L1	INSERTO	Tornillo Placa	Llave
NPDF90-490R08-D063-E22-6R	63	6	22	40	5.5	490R-08T3..	TDA-014	LLT-8
NPDF90-490R14-D050-E22-4R	50	4	22	40	10	490R-1404..	TDA-047	LLT-15
NPDF90-490R14-D063-E22-5R	63	5	22	40	10			
NPDF90-490R14-D080-E27-7R	80	7	27	50	10			
NPDF90-490R14-D100-E32-7R	100	7	32	50	10			
NPDF90-490R14-D125-E40-8	125	8	40	63	10			
NPDF90-490R14-D160-E40-12	160	12	40	63	10			
NPDF90-490R14-D200-E60-16	200	16	60	63	10			

Plato de Fresado 90° - RT1003..

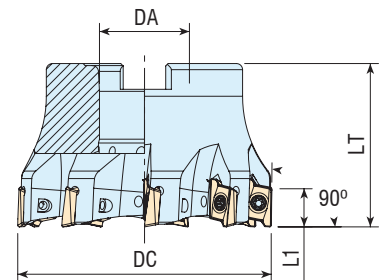

REFERENCIA	DC	Z	DA	LT	L1	INSERTO	Tornillo Placa	Llave
NPDF90-RT10-D040-E16-6R	40	6	16	40	10	RT1003..	TDA-014	LLT-8
NPDF90-RT10-D050-E22-7R	50	7	22	40	10			
NPDF90-RT10-D063-E22-9R	63	9	22	40	10			

Plato de Fresado 90° - SEET09T3..

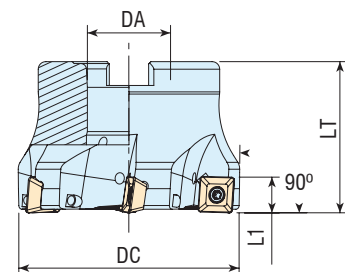

REFERENCIA	DC	Z	DA	LT	L1	INSERTO	Tornillo Placa	Llave
NPDF90-SE09-D040-E16-4R	40	4	16	40	6.7	SEET09T3..	TDA-027	LLT-8
NPDF90-SE09-D050-E22-5R	50	5	22	40	6.7			
NPDF90-SE09-D063-E22-6R	63	6	22	40	6.7			

Plato de Fresado 90° - SDMT1204..

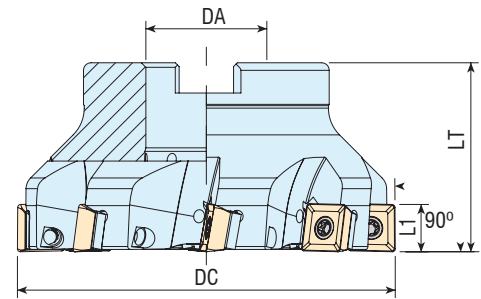

REFERENCIA	DC	Z	DA	LT	L1	INSERTO	Placa base	Tornillo base	Tornillo placa	Llave
NPDF90S-SD1204-D050-E22-4R	50	4	22	40	11	SDMT1204..	PB-024	TPB-013	TDA-050	LLT-15
NPDF90S-SD1204-D063-E22-5R	63	5	22	40	11			TPB-011	TDA-051	LLT-15
NPDF90S-SD1204-D080-E27-6R	80	6	27	50	11					
NPDF90S-SD1204-D100-E32-8R	100	8	32	50	11					
NPDF90S-SD1204-D125-E40-10	125	10	40	63	11					
NPDF90S-SD1204-D160-E40-12	160	12	40	63	11					

Plato de Fresado 90° - SD..09M4.. / SD..1305..

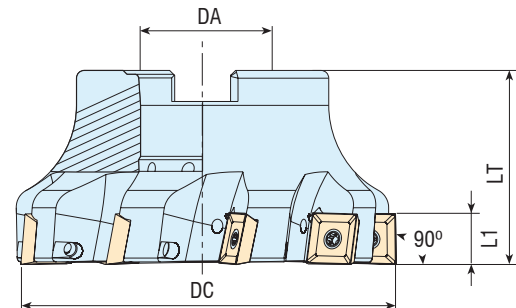
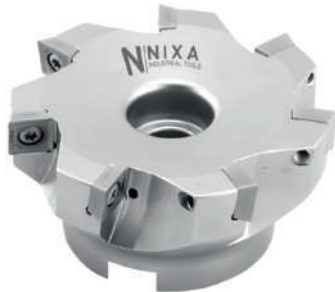

REFERENCIA	DC	Z	DA	LT	L1	INSERTO	Tornillo Placa	Llave
NPDF90-SD09M4-D040-E16-4R	40	4	16	40	9	SD..09M4..	TDA-049	LLT-15
NPDF90-SD09M4-D050-E22-5R	50	5	22	40	9			
NPDF90-SD09M4-D063-E22-6R	63	6	22	40	9			
NPDF90-SD09M4-D080-E27-7R	80	7	27	50	9			
NPDF90-SD1305-D050-E22-4R	50	4	22	40	13	SD..1305..	TDA-081	LLT-20
NPDF90-SD1305-D063-E22-5R	63	5	22	40	13			
NPDF90-SD1305-D080-E27-6R	80	6	27	50	13			
NPDF90-SD1305-D100-E32-7R	100	7	32	50	13			
NPDF90-SD1305-D125-E40-8	125	8	40	63	13			
NPDF90-SD1305-D160-E40-10	160	10	40	63	13			

Plato de Fresado 90° - SEET1203..

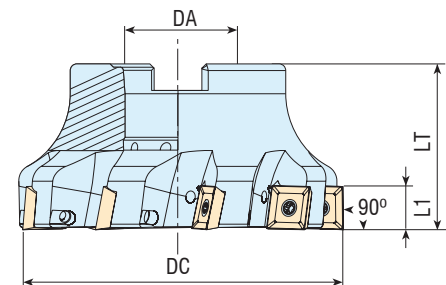

REFERENCIA	DC	Z	DA	LT	L1	INSERTO	Tornillo Placa	Llave
NPDF90-SE12-D050-E22-4R	50	4	22	40	12	SEET1203..	TDA-049	LLT-15
NPDF90-SE12-D063-E22-5R	63	5	22	40	12			
NPDF90-SE12-D080-E27-7R	80	7	27	50	12			
NPDF90-SE12-D100-E32-9R	100	9	32	50	12			
NPDF90-SE12-D125-E40-11	125	11	40	63	12			

Plato de Fresado 90° - SPMT1004.. / XPMT1004.. / QPMR1004.. / QPMT1004..

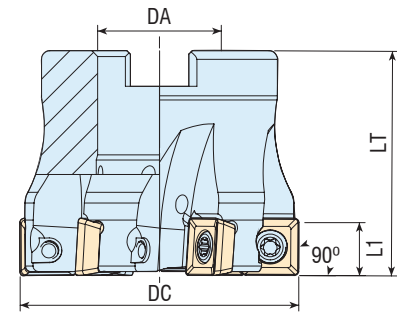

REFERENCIA	DC	Z	DA	LT	L1	INSERTO	Tornillo Placa	Llave
NPDF90-SP1004-D040-E16-4R	40	4	16	40	9.4	SPMT1004..	TDA-065	LLT-15
NPDF90-SP1004-D050-E22-4R	50	4	22	40	9.4	XPMT1004..		
NPDF90-SP1004-D050-E22-6R	50	6	22	40	9.4	QPMR1004..		
NPDF90-SP1004-D063-E22-5R	63	5	22	40	9.4	QPMT1004..		
NPDF90-SP1004-D080-E27-7R	80	7	27	50	9.4			
NPDF90-SP1004-D100-E32-8R	100	8	32	50	9.4			

Plato de Fresado 90° - SPMT09T3..

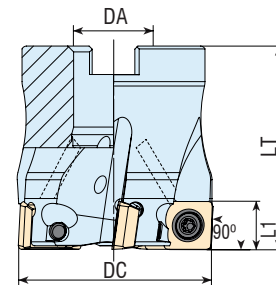

REFERENCIA	DC	Z	DA	LT	L1	INSERTO	Tornillo Placa	Llave
NPDF90-SP09T3-D040-E16-5R	40	5	16	40	8.6	SPMT09T3..	TDA-044	LLT-10
NPDF90-SP09T3-D050-E22-6R	50	6	22	40	8.6			
NPDF90-SP09T3-D063-E22-7R	63	7	22	40	8.6			
NPDF90-SP09T3-D080-E27-8R	80	8	27	50	8.6			

Plato de Fresado 90° - TN.X2207..

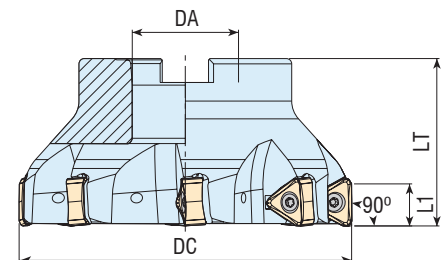

REFERENCIA	DC	Z	DA	LT	L1	INSERTO	Tornillo Placa	Llave
NPDF90-TN2207-D063-E22-4R	63	4	22	40	15	TN.X2207..	TDA-075	LLT-20
NPDF90-TN2207-D080-E27-5R	80	5	27	50	15			
NPDF90-TN2207-D100-E32-6	100	6	32	50	15			
NPDF90-TN2207-D125-E40-8	125	8	40	63	15			

Plato de Fresado 90° - TPKT2205..

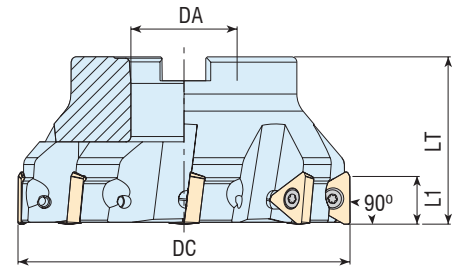

REFERENCIA	DC	Z	DA	LT	L1	INSERTO	Tornillo Placa	Llave
NPDF90-TP2205-D063-E22-4	63	4	22	40	18	TPKT2205..	TDA-075	LLT-20
NPDF90-TP2205-D080-E27-6	80	6	27	50	18			
NPDF90-TP2205-D100-E32-7	100	7	32	50	18			
NPDF90-TP2205-D125-E40-8	125	8	40	63	18			
NPDF90-TP2205-D160-E40-9	160	9	40	63	18			
NPDF90-TP2205-D200-E60-12	200	12	60	63	18			

Plato de Fresado 90° - VCKT2205..

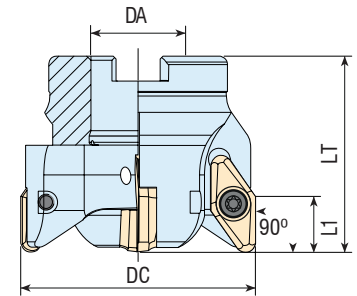

REFERENCIA	DC	Z	DA	LT	L1	INSERTO	Tornillo Placa	Llave
NPDF90-VC2205-D050-E22-3R	50	3	22	55	15	VCKT2205..	TDA-077	LLT-15
NPDF90-VC2205-D063-E22-4R	63	4	22	55	15			
NPDF90-VC2205-D066-E27-4R	66	4	27	55	15			
NPDF90-VC2205-D080-E27-5R	80	5	27	60	15			

Plato de Fresado 90° - WNGU0403.. / WNGU0806..

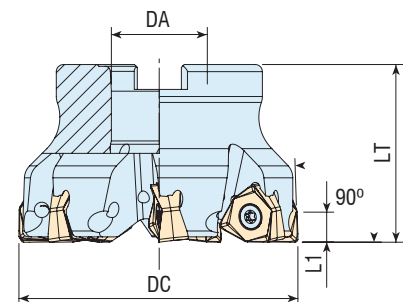

REFERENCIA	DC	Z	DA	LT	L1	INSERTO	Tornillo Placa	Llave
NPDF90-WNG04-D040-E16-6R	40	6	16	40	4	WNGU0403..	TDA-014	LLT-8
NPDF90-WNG04-D050-E22-5R	50	5	22	40	4			
NPDF90-WNG04-D050-E22-7R	50	7	22	40	4			
NPDF90-WNG04-D063-E22-6R	63	6	22	40	4			
NPDF90-WNG08-D050-E22-5R	50	5	22	40	7.5	WNGU0806..	TDA-066	LLT-15
NPDF90-WNG08-D063-E22-6R	63	6	22	40	7.5			
NPDF90-WNG08-D080-E27-7R	80	7	27	50	7.5			

Plato de Fresado 90° - WNGU0403.. / WNGU0806..

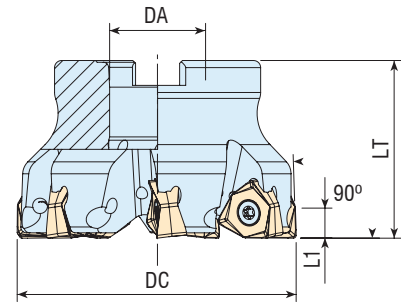

REFERENCIA	DC	Z	DA	LT	L1	INSERTO	Tornillo Placa	Llave
NPDF90-WNG04-D040-E16-6R	40	6	16	40	4	WNGU0403..	TDA-014	LLT-8
NPDF90-WNG04-D050-E22-5R	50	5	22	40	4			
NPDF90-WNG04-D050-E22-7R	50	7	22	40	4			
NPDF90-WNG04-D063-E22-6R	63	6	22	40	4			
NPDF90-WNG08-D050-E22-5R	50	5	22	40	7.5	WNGU0806..	TDA-066	LLT-15
NPDF90-WNG08-D063-E22-6R	63	6	22	40	7.5			
NPDF90-WNG08-D080-E27-7R	80	7	27	50	7.5			

Plato de Fresado 90° - WNHU0604.. / WNHU0806..

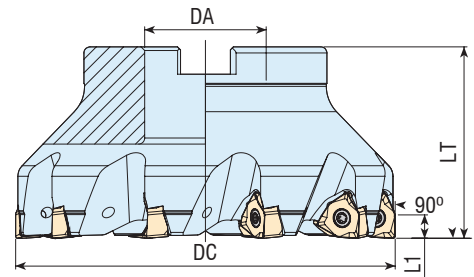

REFERENCIA	DC	Z	DA	LT	L1	INSERTO	Tornillo Placa	Llave
NPDF90-WN0604Z-D040-E16-4R	40	4	16	40	5.7	WNHU0604..	TDA-027	LLT-8
NPDF90-WN0604Z-D050-E22-5R	50	5	22	40	5.7			
NPDF90-WN0604Z-D063-E22-6R	63	6	22	40	5.7			
NPDF90-WN0604Z-D080-E27-7R	80	7	27	50	5.7			
NPDF90-WN0604Z-D100-E32-9R	100	9	32	50	5.7			
NPDF90-WN0806Z-D050-E22-4R	50	4	22	40	7.7	WNHU0806..	TDA-066	LLT-15
NPDF90-WN0806Z-D063-E22-5R	63	5	22	40	7.7			
NPDF90-WN0806Z-D080-E27-6R	80	6	27	50	7.7			
NPDF90-WN0806Z-D100-E32-8R	100	8	32	50	7.7			
NPDF90-WN0806Z-D125-E40-10	125	10	40	63	7.7			
NPDF90-WN0806Z-D160-E40-12	160	12	40	63	7.7			

Plato de Fresado 90° - WNMX080608

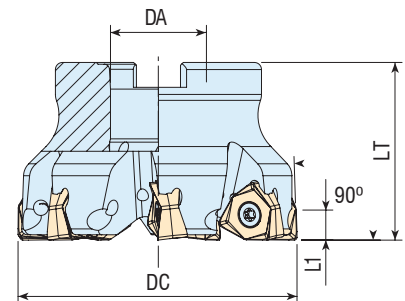

REFERENCIA	DC	Z	DA	LT	L1	INSERTO	Tornillo Placa	Llave
NPDF90-WN0806-D050-E16-4R	50	4	16	40	8	WNMX080608	TDA-084	LLT-15
NPDF90-WN0806-D063-E22-5R	63	5	22	40	8			
NPDF90-WN0806-D080-E27-7R	80	7	27	50	8			

Plato de Fresado 90° - XNEX0403.. / XNEX0806..

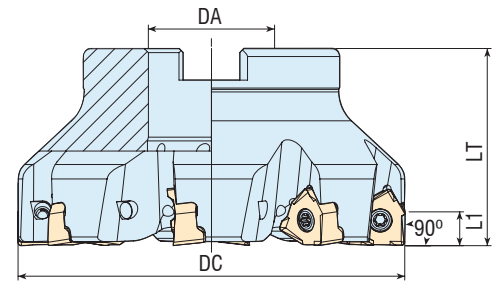

REFERENCIA	DC	Z	DA	LT	L1	INSERTO	Tornillo Placa	Llave
NPDF90-XN0403-D040-E16-5R	40	5	16	40	4	XNEX0403..	TDA-014	LLT-8
NPDF90-XN0806-D050-E22-4R	50	4	22	40	7.5	XNEX0806..	TDA-066	LLT-15
NPDF90-XN0806-D063-E22-5R	63	5	22	40	7.5			
NPDF90-XN0806-D080-E27-7R	80	7	27	50	7.5			
NPDF90-XN0806-D100-E32-8R	100	8	32	50	7.5			

Plato de Fresado 90° - XO..1204..

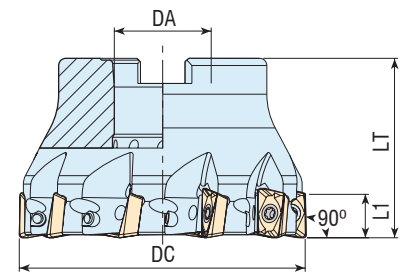

REFERENCIA	DC	Z	DA	LT	L1	INSERTO	Tornillo Placa	Llave
NPDF90-XO12-D040-E16-5R	40	5	16	40	11	XO..1204..	TDA-044	LLT-10
NPDF90-XO12-D050-E22-7R	50	7	22	40	11			
NPDF90-XO12-D063-E22-8R	63	8	22	40	11			
NPDF90-XO12-D080-E27-10R	80	10	27	50	11			
NPDF90-XO12-D100-E32-12R	100	12	32	50	11			

Plato de Fresado 90° - 4NKT0603..

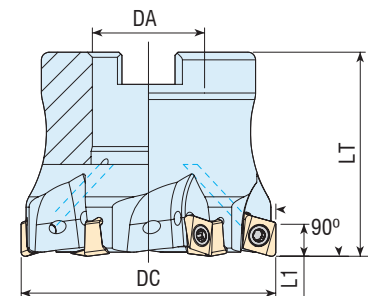

REFERENCIA	DC	Z	DA	LT	L1	INSERTO	Tornillo Placa	Llave
NPDF90-4N06-D040-E16-5R	40	5	16	40	6	4NKT0603..	TDA-024	LLT-8
NPDF90-4N06-D050-E22-6R	50	6	22	40	6			

Plato de Fresado 90° - 3PKT1004..

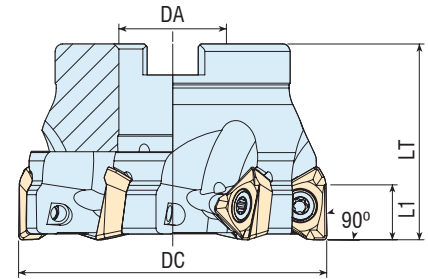

REFERENCIA	DC	Z	DA	LT	L1	INSERTO	Tornillo Placa	Llave
NPDF90-3P1004-D040-E16-5R	40	5	16	40	7	3PKT1004..	TDA-012	LLT-8
NPDF90-3P1004-D050-E22-6R	50	6	22	40	7			
NPDF90-3P1505-D050-E22-4R	50	4	22	40	11	3PKT1505..	TDA-056	LLT-15
NPDF90-3P1505-D050-E22-5R	50	5	22	40	11			
NPDF90-3P1505-D063-E22-4R	63	4	22	40	11			
NPDF90-3P1505-D063-E22-6R	63	6	22	40	11			
NPDF90-3P1505-D080-E27-7R	80	7	27	50	11			
NPDF90-3P1505-D100-E32-8R	100	8	32	50	11			
NPDF90-3P1505-D125-E40-10	125	10	40	63	11			

Plato de Fresado - RC..10T3..

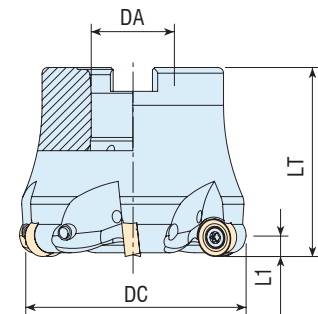

REFERENCIA	DC	Z	DA	LT	L1	INSERTO	Tornillo Placa	Llave
NPDFR-RC10T3-D040-E16-4R	40	4	16	40	5	RC..10T3..	TDA-066	LLT-15
NPDFR-RC10T3-D050-E22-5R	50	5	22	50	5			
NPDFR-RC10T3-D063-E22-6R	63	6	22	50	5			

Plato de Fresado - RPNX10T3.. / RPNX1204..

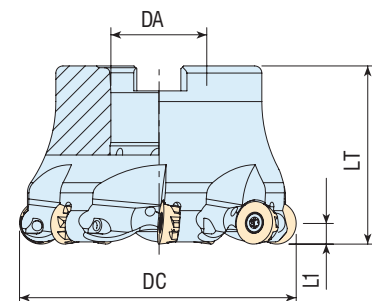

REFERENCIA	DC	Z	DA	LT	L1	INSERTO	Tornillo Placa	Llave
NPDFR-RP10T3-D063-E22-6R	63	6	22	40	5	RPNX10T3..	TDA-032	LLT-10
NPDFR-RP10T3-D080-E27-7R	80	7	27	50	5			
NPDFR-RP1204-D040-E16-4R	40	4	16	40	6	RPNX1204..	TDA-049	LLT-15
NPDFR-RP1204-D080-E27-7R	80	7	27	50	6			

Plato de Fresado - RC..1204..

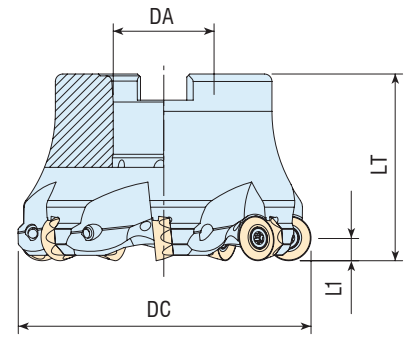

REFERENCIA	DC	Z	DA	LT	L1	INSERTO	Tornillo Placa	Llave
NPDFR-RC1204-D040-E16-4R	40	4	16	40	6	RC..1204..	TDA-049	LLT-15
NPDFR-RC1204-D050-E22-5R	50	5	22	50	6			
NPDFR-RC1204-D052-E22-5R	52	5	22	50	6			
NPDFR-RC1204-D063-E22-6R	63	6	22	50	6			
NPDFR-RC1204-D063-E27-6R	80	6	27	50	6			
NPDFR-RC1204-D080-E27-7R	80	7	27	50	6			

Plato de Fresado - QP..10T3.. / QP..1204..

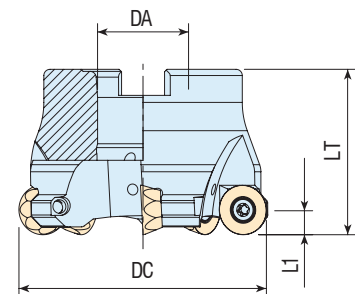

REFERENCIA	DC	Z	DA	LT	L1	INSERTO	Tornillo Placa	Llave
NPDFR-QP10T3-D040-E16-4R	40	4	16	40	5	QP..10T3..	TDA-049	LLT-15
NPDFR-QP10T3-D050-E22-5R	50	5	22	40	5			
NPDFR-QP10T3-D063-E22-6R	63	6	22	40	5			
NPDFR-QP1204-D050-E22-4R	50	4	22	40	6	QP..1204..	TDA-066	LLT-15
NPDFR-QP1204-D063-E22-5R	63	5	22	40	6			

Plato de Fresado - RPMT1204..

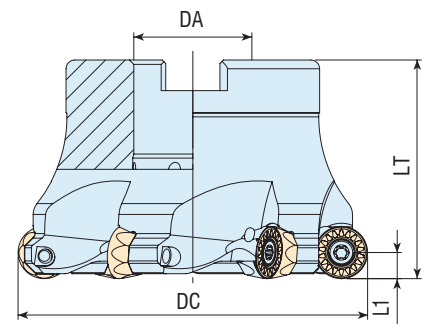

REFERENCIA	DC	Z	DA	LT	L1	INSERTO	Tornillo Placa	Llave
NPDFR-RP1204M-D050-E22-4R	50	4	22	50	6	RPMT1204..	TDA-066	LLT-15
NPDFR-RP1204M-D052-E22-5R	52	5	22	50	6			
NPDFR-RP1204M-D063-E22-5R	63	6	22	50	6			
NPDFR-RP1204M-D080-E27-6R	80	7	27	50	6			

Plato de Fresado - RD..

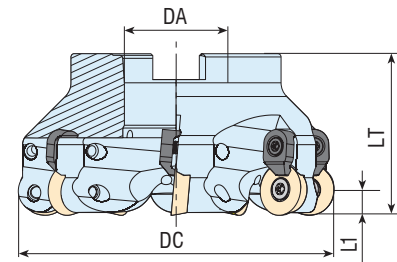

REFERENCIA	DC	Z	DA	LT	L1	INSERTO	Tornillo Placa	Brida Placa	Tornillo Brida	Llave
NPDFR-RD0702-D050-E22-6R	50	6	22	40	3.5	RD..0702..	TDA-014	-	-	LLT-8
NPDFR-RD0803-D050-E22-5R	50	5	22	40	4	RD..0803..	TDA-027	-	-	LLT-8
NPDFRC-RD1003-D040-E16-4R	40	4	16	40	5	RD..1003..	TDA-049	BDA-26	TDA-049	LLT-15
NPDFRC-RD1003-D050-E22-5R	50	5	22	50	5					
NPDFRC-RD1003-D052-E22-5	52	5	22	50	5					
NPDFRC-RD1003-D063-E22-6R	63	6	22	50	5					
NPDFRC-RD1003-D080-E27-7R	80	7	27	50	5					
NPDFRC-RD1003-D100-E32-8R	100	8	32	50	5					
NPDFRC-RD10T3-D050-E22-5R	50	5	22	50	5	RD..10T3..	TDA-049	BDA-26	TDA-049	LLT-15
NPDFRC-RD10T3-D063-E22-6R	63	6	22	50	5					
NPDFRC-RD12T3-D040-E16-4R	40	4	16	40	6	RD..12T3..	TDA-049	BDA-26	TDA-049	LLT-15
NPDFRC-RD12T3-D050-E22-5R	50	5	22	50	6					
NPDFRC-RD12T3-D052-E22-5R	52	5	22	50	6					
NPDFRC-RD12T3-D063-E22-6R	63	6	22	50	6					
NPDFRC-RD12T3-D080-E27-7R	80	7	27	50	6					
NPDFRC-RD12T3-D100-E32-8R	100	8	32	50	6					
NPDFRC-RD12T3-D125-E40-9	125	9	40	63	6					
NPDFRC-RD1204-D040-E16-4R	40	4	16	40	6	RD..1204..	TDA-049	BDA-26	TDA-049	LLT-15
NPDFRC-RD1204-D050-E22-5R	50	5	22	50	6					
NPDFRC-RD1204-D052-E22-5R	52	5	22	50	6					
NPDFRC-RD1204-D063-E22-6R	63	6	22	50	6					
NPDFRC-RD1204-D080-E27-7R	80	7	27	50	6					
NPDFRC-RD1204-D100-E32-7R	100	7	32	50	6					
NPDFRC-RD1204-D100-E32-8R	100	8	32	50	6					
NPDFRC-RD1604-D050-E22-4R	50	4	22	50	8	RD..1604..	TDA-077	BDA-18	TDA-066	LLT-15
NPDFRC-RD1604-D052-E22-4R	52	4	22	50	8					
NPDFRC-RD1604-D063-E22-5R	63	5	22	50	8					
NPDFRC-RD1604-D066-E22-5R	66	5	22	50	8					
NPDFRC-RD1604-D066-E27-5R	66	5	27	50	8					
NPDFRC-RD1604-D080-E27-6R	80	6	27	50	8					
NPDFRC-RD1604-D100-E32-7R	100	7	32	50	8					
NPDFRC-RD1604-D125-E40-7	125	7	40	63	8					
NPDFRC-RD1604-D160-E40-8	160	8	40	63	8					

Plato de Fresado - RYMX1004.. / RYMX1205..

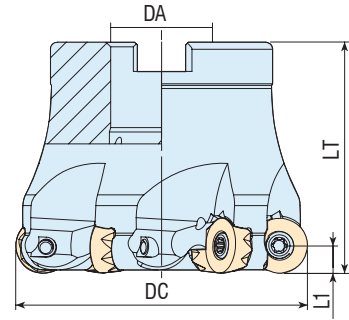

REFERENCIA	DC	Z	DA	LT	L1	INSERTO	Tornillo Placa	Llave
NPDFR-RY10-D040-E16-4R	40	4	16	40	5	RYMX1004..	TDA-049	LLT-15
NPDFR-RY10-D040-E16-5R	40	5	16	40	5			
NPDFR-RY10-D050-E22-5R	50	5	22	50	5			
NPDFR-RY10-D063-E22-6R	63	6	22	50	5			
NPDFR-RY12-D040-E16-4R	40	4	16	40	6	RYMX1205..	TDA-066	LLT-15
NPDFR-RY12-D050-E22-5R	50	5	22	50	6			
NPDFR-RY12-D052-E22-5R	52	5	22	50	6			
NPDFR-RY12-D063-E22-6R	63	6	22	50	6			
NPDFR-RY12-D080-E27-6R	80	6	27	50	6			
NPDFR-RY12-D100-E32-7R	100	7	32	50	6			

Plato de Fresado 43° - OF..0704..

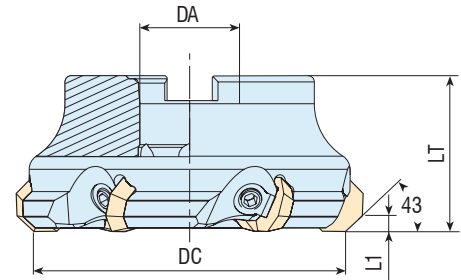

REFERENCIA	DC	Z	DA	LT	L1	INSERTO	Brida Placa	Tornillo Brida	Llave
NPDF43C-OF07-D063-E22-4	63	4	22	45	5	OF..0704..	BDA-24	TPA-012	LLA-4
NPDF43C-OF07-D080-E27-5	80	5	27	50	5				
NPDF43C-OF07-D100-E32-6	100	6	32	50	5				
NPDF43C-OF07-D125-E40-8	125	8	40	63	5				
NPDF43C-OF07-D160-E40-9	160	9	40	63	5				

Plato de Fresado 45° - HN..0905..

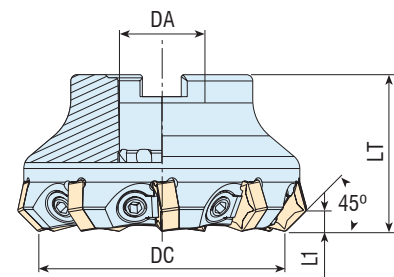

REFERENCIA	DC	Z	DA	LT	L1	INSERTO	Brida Placa	Tornillo Brida	Llave
NPDF45C-HN0905-D063-E22-7	63	7	22	40	4.5	HN..0905..	BDA-24	TPA-012	LLA-4
NPDF45C-HN0905-D080-E27-9	80	9	27	50	4.5				
NPDF45C-HN0905-D100-E32-11	100	11	32	50	4.5				
NPDF45C-HN0905-D125-E40-13	125	13	40	63	4.5				
NPDF45C-HN0905-D160-E40-15	160	15	40	63	4.5				

Plato de Fresado 45° - XNMU0806..

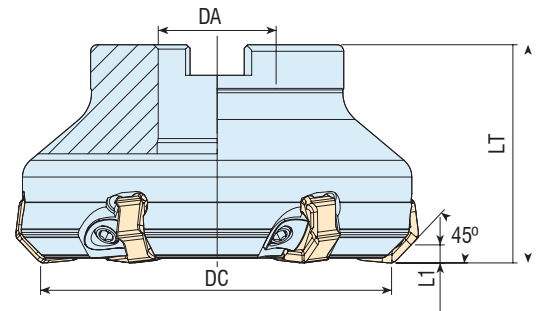

REFERENCIA	DC	Z	DA	LT	L1	INSERTO	Brida Placa	Tornillo Brida	Llave
NPDF45C-XN0806-D063-E22-5	63	5	22	50	4.5	XNMU0806..	BDA-31	TPA-016	LLA-3
NPDF45C-XN0806-D080-E27-6	80	6	27	50	4.5				
NPDF45C-XN0806-D100-E32-8	100	8	32	50	4.5				
NPDF45C-XN0806-D125-E40-8	125	8	40	63	4.5				
NPDF45C-XN0806-D160-E40-10	160	10	40	63	4.5				
NPDF45C-XN0806-D200-E60-12	200	12	60	63	4.5				

Plato de Fresado 75° - SPKN1203..

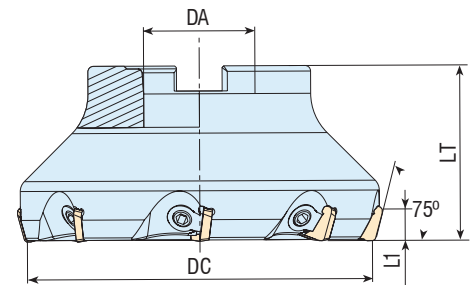

REFERENCIA	DC	Z	DA	LT	L1	INSERTO	Brida Placa	Tornillo Brida	Llave
NPDF75C-SP12-D050-E22-4	50	4	22	42	8	SPKN1203..	BDA-23	TPA-014	LLA-4
NPDF75C-SP12-D063-E22-5	63	5	22	40	8			TPA-010	LLA-4
NPDF75C-SP12-D080-E27-6	80	6	27	50	8				
NPDF75C-SP12-D100-E32-7	100	7	32	50	8				
NPDF75C-SP12-D125-E40-8	125	8	40	63	8				
NPDF75C-SP12-D160-E40-9	160	9	40	63	8				
NPDF75C-SP12-D200-E60-12	200	12	60	63	8				

Plato de Fresado 88° - SN..1204..

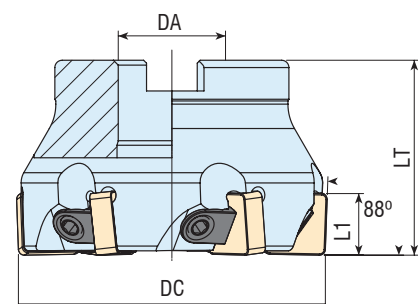

REFERENCIA	DC	Z	DA	LT	L1	INSERTO	Brida Placa	Tornillo Brida	Llave
NPDF88C-SN1204-D050-E22-5	50	5	22	40	11	SN..1204..	BDA-28	TPA-015	LLA-3
NPDF88C-SN1204-D063-E22-6	63	6	22	40	11				
NPDF88C-SN1204-D080-E27-7	80	7	27	50	11				
NPDF88C-SN1204-D100-E32-8	100	8	32	50	11				
NPDF88C-SN1204-D125-E40-11	125	11	40	63	11				

Plato de Fresado 90° - TP..1603.. / TP..2204..

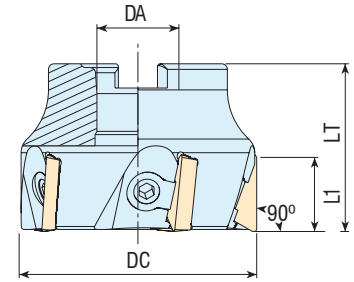

REFERENCIA	DC	Z	DA	LT	L1	INSERTO	Brida Placa	Tornillo Brida	Llave
NPDF90C-TP16-D050-E22-4	50	4	22	40	12	TP..1603..	BDA-23	TPA-014	LLA-4
NPDF90C-TP16-D063-E22-6	63	6	22	45	12			TPA-010	LLA-4
NPDF90C-TP16-D080-E27-7	80	7	27	50	12		BDA-24	TPA-011	LLA-4
NPDF90C-TP16-D100-E32-8	100	8	32	50	12				
NPDF90C-TP16-D125-E40-8	125	8	40	63	12				
NPDF90C-TP22-D063-E22-5	63	5	22	45	18	TP..2204..	BDA-24	TPA-011	LLA-4
NPDF90C-TP22-D080-E27-6	80	6	27	50	18				
NPDF90C-TP22-D100-E32-7	100	7	32	50	18				
NPDF90C-TP22-D125-E40-8	125	8	40	63	18				
NPDF90C-TP22-D160-E40-9	160	9	40	63	18				
NPDF90C-TP22-D200-E60-12	200	12	60	63	18				
NPDF90C-TP22-D250-E60-15	250	15	60	63	18				
NPDF90C-TP22-D315-E60-Z18	315	18	60	63	18				

Plato de Fresado - EP1003.. / ZPMT1003.. / YPHW1003..

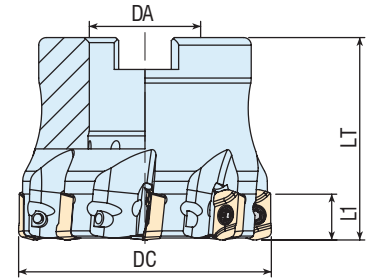

REFERENCIA	dcx	zepf	dcpon	lf	apmx	INSERTO	Tornillo Placa	Llave
NPDA-EP1003-D050-E22-8R	50	8	22	40	1	-	TDA-014	LLT-8
NPDA-EP1003-D063-E22-8R	63	8	22	40	1			

Plato de Fresado - ENMU1004..

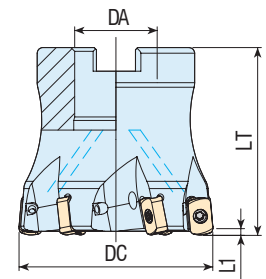

REFERENCIA	dcx	zepf	dcpon	lf	apmx	INSERTO	Tornillo Placa	Llave
NPDA-EN1004-D050-E22-5R	50	5	22	50	1	ENMU1004..	TDA-014	LLT-8
NPDA-EN1004-D050-E22-6R	50	6	22	50	1			
NPDA-EN1004-D052-E22-6R	52	6	22	50	1			
NPDA-EN1004-D063-E22-6R	63	6	22	50	1			

Plato de Fresado - BLP0603 / BLP0904..

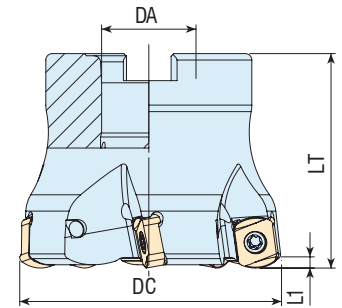

REFERENCIA	dcx	zepf	dcpon	lf	apmx	INSERTO	Tornillo Placa	Llave
NPDAА-BL0603-D040-E16-6R	40	6	16	40	1	BLMP0603..	TDA-014	LLT-8
NPDAА-BL0603-D050-E22-7R	50	7	22	40	1			
NPDAА-BL0904-D040-E16-5R	40	5	16	40	2	BLMP0904..	TDA-044	LLT-10
NPDAА-BL0904-D050-E22-6R	50	6	22	50	2			
NPDAА-BL0904-D063-E22-5R	63	5	22	50	2			
NPDAА-BL0904-D063-E22-7R	63	7	22	63	2			

Plato de Fresado - BLMP1205..

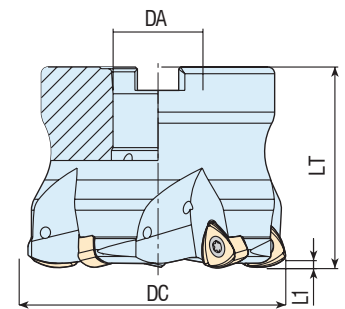

REFERENCIA	dcx	zepf	dcpon	lf	apmx	INSERTO	Tornillo Placa	Llave
NPDAА-BL1205-D050-E22-3R	50	3	22	40	2	BLMP1205..	TDA-066	LLT-15
NPDAА-BL1205-D063-E22-4R	63	4	22	40	2			
NPDAА-BL1205-D080-E27-5R	80	5	27	50	2			

Plato de Fresado - LOGU0303..

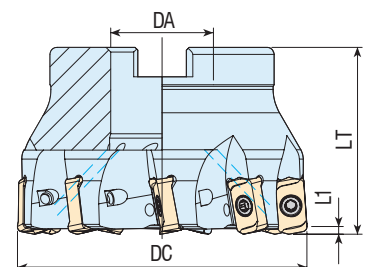

REFERENCIA	dcx	zepf	dcpon	lf	apmx	INSERTO	Tornillo Placa	Llave
NPDAА-LO03-D040-E16-6R	40	6	16	40	1	LOGU0303	TDA-024	LLT-8
NPDAА-LO03-D050-E22-7R	50	7	22	40	1			
NPDAА-LO03-D063-E22-9R	63	9	22	40	1			

Plato de Fresado - LNMU0303..

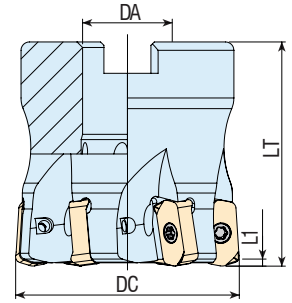

REFERENCIA	dcx	zepf	dcpon	lf	apmx	INSERTO	Tornillo Placa	Llave
NPDAALN0303-D040-E16-6R	40	6	16	40	12	LNMU0303..	TDA-014	LLT-8
NPDAALN0303-D050-E22-7R	50	7	22	50	12			
NPDAALN0303-D063-E22-9R	63	9	22	50	12			

Plato de Fresado - JDMT1003..

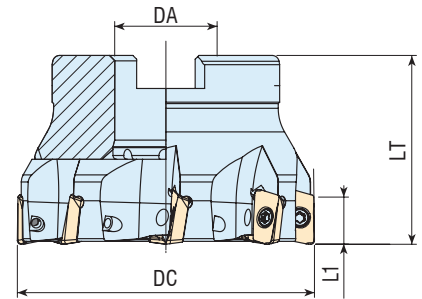

REFERENCIA	dcx	zepf	dcpon	lf	apmx	INSERTO	Tornillo Placa	Llave
NPDAAJD1003-D040-E16-6R	40	6	16	40	9	JDMT1003..	TDA-014	LLT-8
NPDAAJD1003-D063-E22-8R	63	8	22	40	9			

Plato de Fresado - JDMW1204.. / JDMW1405..

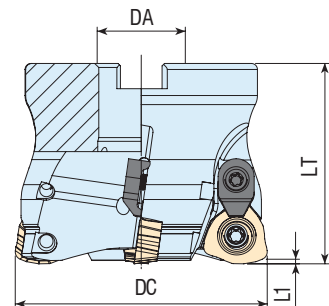

REFERENCIA	dcx	zepf	dcpon	lf	apmx	INSERTO	Tornillo Placa	Brida Placa	Tornillo Brida	Llave
NPDAACJD1204-D052-E22-3R	52	3	22	50	1.5	JDMW1204..	TDA-071	BDA-18	TDA-066	LLT-15
NPDAACJD1204-D052-E22-4R	52	4	22	50	1.5					
NPDAACJD1204-D063-E22-5R	63	5	22	50	1.5					
NPDAACJD1204-D080-E27-6R	80	6	27	50	1.5					
NPDAACJD1204-D100-E32-7R	100	7	32	50	1.5					
NPDAACJD1405-D052-E22-3R	52	3	22	40	2	JDMW1405..	TDA-081	BDA-18	TDA-066	LLT-20
NPDAACJD1405-D063-E22-4R	63	4	22	40	2					

Plato de Fresado - SD..1204

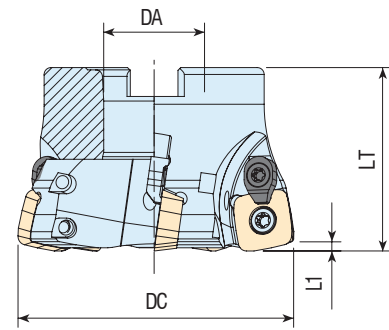

REFERENCIA	dcx	zepf	dcpon	lf	apmx	INSERTO	Tornillo Placa	Brida Placa	Tornillo Brida	Llave
NPDAА-SD1204-D050-E22-4R	50	4	22	40	1.8	SD..1204..	TDA-066	BDA-26	TDA-049	LLT-15
NPDAА-SD1204-D063-E22-5R	63	5	22	40	1.8					
NPDAА-SD1204-D080-E27-6R	80	6	27	50	1.8					
NPDAА-SD1204-D100-E32-8R	100	8	32	50	1.8					

Plato de Fresado - SD..1205..

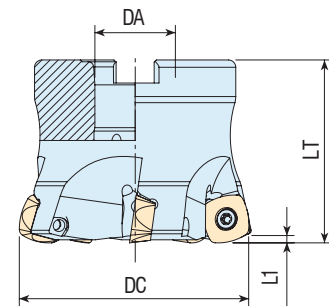

REFERENCIA	dcx	zepf	dcpon	lf	apmx	INSERTO	Tornillo Placa	Llave
NPDAА-SD1205-D052-E22-4R	52	4	22	50	2	SD..1205..	TDA-066	LLT-15
NPDAА-SD1205-D052-E22-5R	52	5	22	50	2			
NPDAА-SD1205-D066-E22-5R	66	5	22	50	2			
NPDAА-SD1205-D066-E22-6R	66	6	22	50	2			
NPDAА-SD1205-D080-E27-6R	80	6	27	70	2			

Plato de Fresado - SOMT1004..

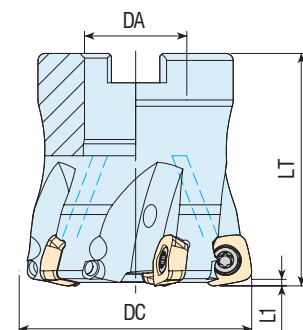

REFERENCIA	dcx	zepf	dcpon	lf	apmx	INSERTO	Tornillo Placa	Llave
NPDAА-SO1004-D050-E22-5R	50	5	22	50	1.5	SOMT1004..	TDA-066	LLT-15
NPDAА-SO1004-D063-E22-6R	63	6	22	50	1.5			
NPDAА-SO1004-D080-E27-7R	80	7	27	63	1.5			

Plato de Fresado - SPNW1004..

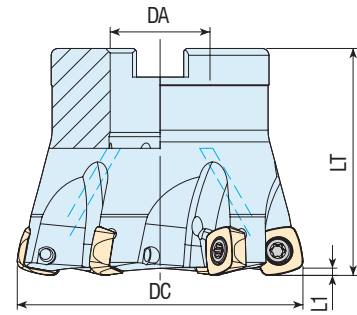

REFERENCIA	dcx	zepf	dcpon	lf	apmx	INSERTO	Tornillo Placa	Llave
NPDAА-SP1004-D050-E22-5R	50	5	22	50	1.5	SPNW1004..	TDA-045	LLT-15
NPDAА-SP1004-D052-E22-5R	52	5	22	50	1.5			
NPDAА-SP1004-D063-E22-6R	63	6	22	50	1.5			

Plato de Fresado - WD.W06T3.. / WD.W0805.. / WD.W10X6..

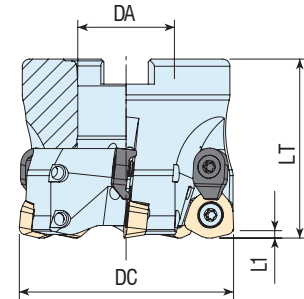

REFERENCIA	dcx	zepf	dcpon	lf	apmx	INSERTO	Tornillo Placa	Brida Placa	Tornillo Brida	Llave
NPDAAC-WD06T3D-D042-E16-4R	42	4	16	45	1.5	WD.W06T3..	TDA-045	BDA-26	TDA-049	LLT-15
NPDAAC-WD06T3D-D050-E22-5R	50	5	22	50	1.5					
NPDAAC-WD06T3D-D052-E22-5R	52	5	22	50	1.5					
NPDAAC-WD0805D-D052-E22-4R	52	4	22	50	2	WD.W0805..	TDA-079	BDA-27	TDA-079	LLT-20
NPDAAC-WD0805D-D063-E22-5R	63	5	22	50	2					
NPDAAC-WD0805D-D063-E27-5R	63	5	27	50	2					
NPDAAC-WD0805D-D066-E27-5R	66	5	27	50	2					
NPDAAC-WD0805D-D080-E27-5	80	5	27	50	2					
NPDAAC-WD0805D-D100-E32-6	100	6	32	50	2					
NPDAAC-WD10X6D-D125-E40-6	125	6	40	63	2.5	WD.W10X6..	TDA-079	BDA-27	TDA-079	LLT-20
NPDAAC-WD10X6D-D160-E40-7	160	7	40	63	2.5					

Plato de Fresado - WNMX09T3..



- Compatible con placas KRLY
- Placas no disponibles

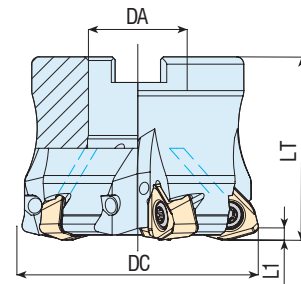

REFERENCIA	dcx	zepf	dcpon	lf	apmx	INSERTO	Tornillo Placa	Llave
NPDAА-WN09T3-D040-E16-4R	40	4	16	40	1.5	WNMX09T3..	TDA-032	LLT-10
NPDAА-WN09T3-D050-E22-5R	50	5	22	40	1.5			
NPDAА-WN09T3-D063-E22-6R	63	6	22	40	1.5			

Plato de Fresado - WDMT0804.. / WDMT1205..

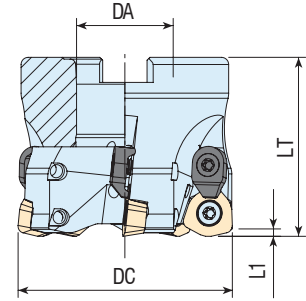

REFERENCIA	dcx	zepf	dcpon	lf	apmx	INSERTO	Tornillo Placa	Brida Placa	Tornillo Brida	Llave
NPDAAC-WD0804-D040-E16-4R	40	4	16	40	1.5	WDMT0804..	TDA-032	BDA-26	TDA-032	LLT-10
NPDAAC-WD0804-D050-E22-4R	50	4	22	50	1.5					
NPDAAC-WD1205-D050-E22-4R	50	4	22	50	3	WDMT1205..	TDA-058	BDA-18	TDA-066	LLT-15
NPDAAC-WD1205-D052-E22-4R	52	5	22	50	3					
NPDAAC-WD1205-D063-E22-5R	63	6	22	50	3					
NPDAAC-WD1205-D080-E27-6R	80	5	27	63	3					

Plato de Fresado - WNMU0907..

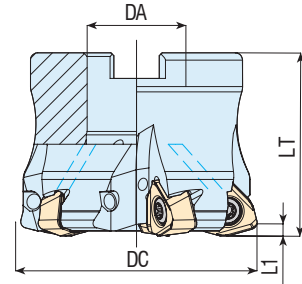

REFERENCIA	dcx	zepf	dcpon	lf	apmx	INSERTO	Tornillo Placa	Llave
NPDAW-WN0907-D050-E22-4R	50	4	22	50	3	WNMU0907..	TDA-082	LLT-20
NPDAW-WN0907-D052-E22-4R	52	4	22	50	3			
NPDAW-WN0907-D063-E22-5R	63	5	22	50	3			
NPDAW-WN0907-D066-E27-5R	66	5	27	50	3			
NPDAW-WN0907-D080-E27-6R	80	6	27	50	3			
NPDAW-WN0907-D100-E32-7R	100	7	32	50	3			

Plato de Fresado 25° - 745..

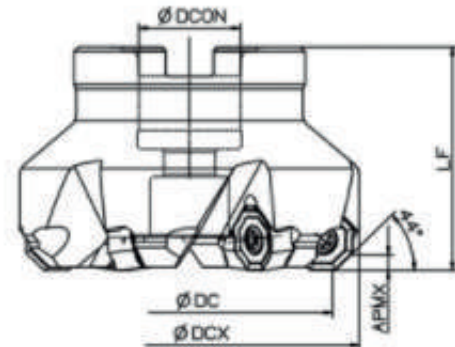

REFERENCIA	øDC	øDCX	Z	øDcon	LT	apmx	INSERTO	Tornillo Placa	Llave
NPDF25-745R-D063-E22-5	63	86.4	5	22	50	2.8	745..	TDA-114	LLT-15
NPDF25-745R-D080-E27-6	80	103.4	6	27	50	2.8			
NPDF25-745R-D100-E32-7	100	123.4	7	32	50	2.8			
NPDF25-745R-D125-E40-8	125	148.4	8	40	63	2.8			

Plato de Fresado 90° - WNGX0806

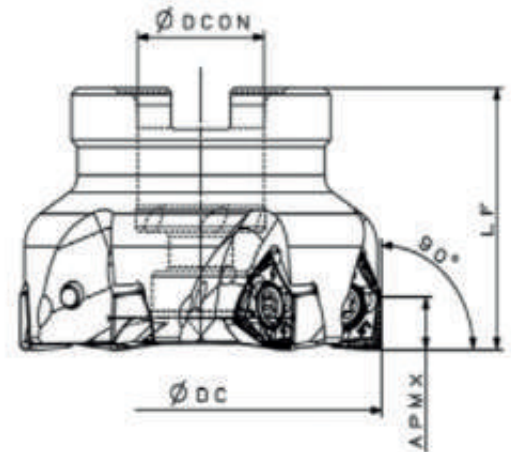

REFERENCIA	ϕDC	Z	$\phi Dcon$	LT	apmx	INSERTO	Tornillo Placa	Llave
NPDF90-WNX08-D050-E22-5R	50	5	22	40	7.5	WNGX0806	TDA-108	LLT-15
NPDF90-WNX08-D063-E22-6R	63	5	22	40	7.5			
NPDF90-WNX08-D080-E27-7R	80	7	27	50	7.5			
NPDF90-WNX08-D100-E32-8	100	8	32	50	7.5			
NPDF90-WNX08-D125-E32-10	125	10	40	63	7.5			

Plato Fresado 90° - TNGX1306

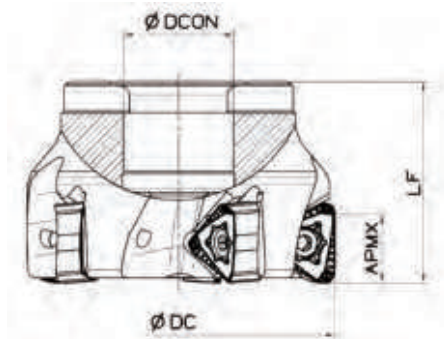

REFERENCIA	ϕDC	Z	$\phi Dcon$	LT	apmx	INSERTO	Tornillo Placa	Llave
NPDF90-TN13-D050-E22-5R	50	5	22	40	7.5	TNGX1306	TDA-109	LLT-15
NPDF90-TN13-D063-E22-6R	63	5	22	40	7.5			
NPDF90-TN13-D080-E27-7R	80	7	27	50	7.5			
NPDF90-TN13-D100-E32-8	100	8	32	50	7.5			
NPDF90-TN13-D125-E32-10	125	10	40	63	7.5			

Plato Fresado 44° - ONMU0504 / ONMU0906

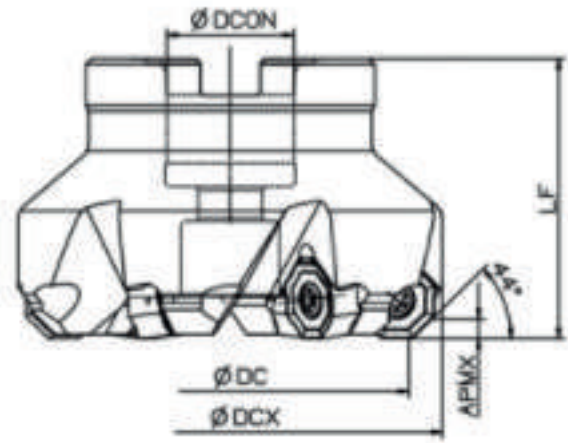

REFERENCIA	ØDC	ØDCX	Z	ØDcon	LT	apmx	INSERTO	Tornillo Placa	Llave
NPDF44-ON0504-D050-5R	50	64.6	5	22	48.4	3.5	ONMU0504	TDA-110	LLT-15
NPDF44-ON0504-D063-6R	63	77.6	6	22	48.4	3.5			
NPDF44-ON0504-D080-7R	80	94.6	7	27	48.4	3.5			
NPDF44-ON0504-D100-8	100	114.6	8	32	48.4	3.5			
NPDF44-ON0504-D125-10	125	139.6	10	40	61.4	3.5			
NPDF44-ON0906-D050-5R	50	76.2	5	22	50	5.5	ONMU0906	TDA-111	LLT-20
NPDF44-ON0906-D063-6R	63	93.2	6	22	50	5.5			
NPDF44-ON0906-D080-7R	80	113.2	7	27	50	5.5			
NPDF44-ON0906-D100-8	100	138.2	8	32	63	5.5			
NPDF44-ON0906-D125-10	125	173.2	10	40	63	5.5			

Plato de Fresado 19° - PDMT1305

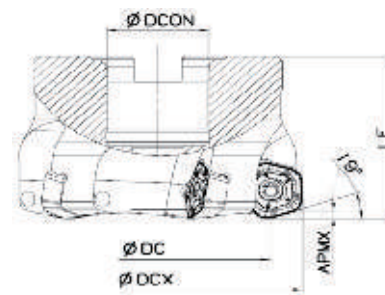
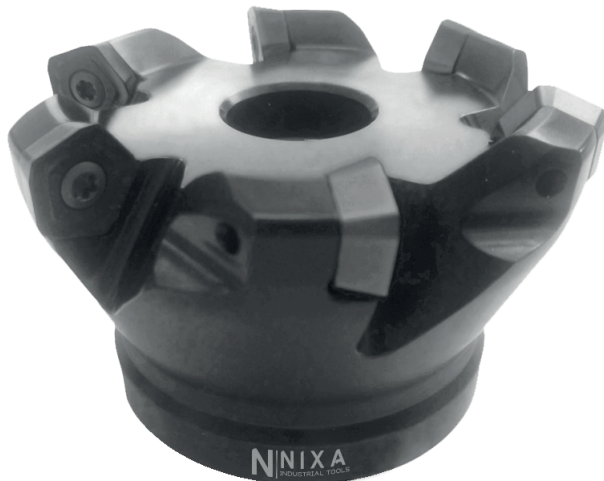

REFERENCIA	ØDC	Z	ØDcon	LT	apmx	INSERTO	Tornillo Placa	Llave
NPDF19-PD13-D050-E22-5R	50	5	22	40	7.5	PDMT1305	TDA-112	LLT-15
NPDF19-PD13-D063-E22-6R	63	5	22	40	7.5			
NPDF19-PD13-D080-E27-7R	80	7	27	50	7.5			
NPDF19-PD13-D100-E32-8	100	8	32	50	7.5			
NPDF19-PD13-D125-E32-10	125	10	40	63	7.5			

Plato de Fresado 45° - SNMX1306

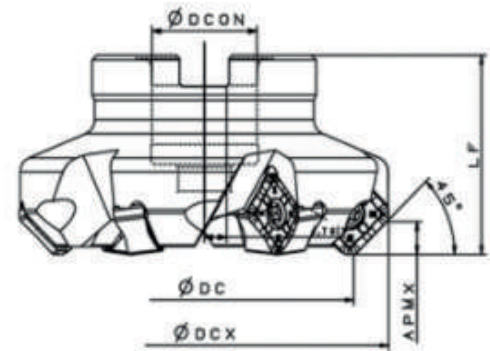

REFERENCIA	$\varnothing DC$	$\varnothing DCX$	Z	$\varnothing DCON$	LT	apmx	INSERTO	Tornillo Placa	Llave
NPDF45-SNMX13-D050-E22-5R	50	64.6	5	22	40	6.5	SNMX1306	TDA-115	LLT-15
NPDF45-SNMX13-D063-E22-6R	63	77.6	5	22	40	6.5			
NPDF45-SNMX13-D080-E27-7R	80	94.6	7	27	50	6.5			
NPDF45-SNMX13-D100-E32-8	100	114.6	8	32	50	6.5			
NPDF45-SNMX13-D125-E32-10	125	139.6	10	40	63	6.5			

Plato de Fresado 75° - SNMX1306

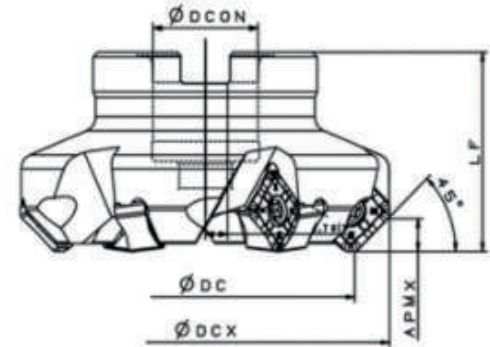

REFERENCIA	$\varnothing DC$	$\varnothing DCX$	Z	$\varnothing DCON$	LT	apmx	INSERTO	Tornillo Placa	Llave
NPDF75-SNMX13-D050-E22-5R	50	56.2	5	22	40	10.3	SNMX1306	TDA-115	LLT-15
NPDF75-SNMX13-D063-E22-6R	63	69.2	5	22	40	10.3			
NPDF75-SNMX13-D080-E27-7R	80	86.2	7	27	50	10.3			
NPDF75-SNMX13-D100-E32-8	100	106.2	8	32	50	10.3			
NPDF75-SNMX13-D125-E32-10	125	131.2	10	40	63	10.3			

Plato de Fresado 88° - SNMX1306

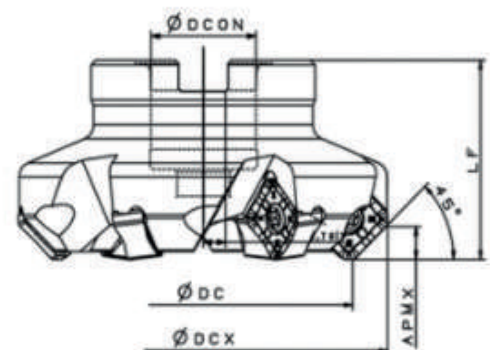

REFERENCIA	$\varnothing DC$	$\varnothing DCX$	Z	$\varnothing DCON$	LT	apmx	INSERTO	Tornillo Placa	Llave
NPDF88-SNMX13-D050-E22-5R	50	50.6	5	22	40	10.9	SNMX1306	TDA-115	LLT-15
NPDF88-SNMX13-D063-E22-6R	63	63.6	5	22	40	10.9			
NPDF88-SNMX13-D080-E27-7R	80	80.6	7	27	50	10.9			
NPDF88-SNMX13-D100-E32-8	100	100.6	8	32	50	10.9			
NPDF88-SNMX13-D125-E32-10	125	125.6	10	40	63	10.9			

Plato de Fresado 90° - CC..

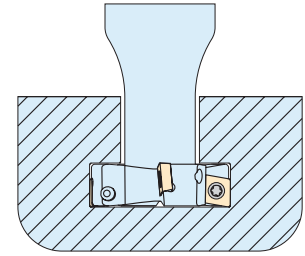
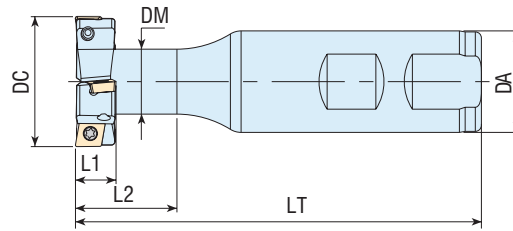

REFERENCIA	Z1	Z2	DC	L1	DA	LT	DM	L2	INSERTO	Tornillo Placa	Llave
NDF90-CC06-D17X8-W16-L85-2	2	1	17	8	16	85	10	16	CC..0602..	TDA-014	LLT-8
NDF90-CC06-D32X8-W25-L100-4	4	2	32	8	25	100	16	23			
NDF90-CC06-D28X8-W20-L66-4	4	2	28	8	20	66	14	15.5			
NDF90-CC06-D45.5X8-W25-L100-6	6	3	45.5	8	25	100	12	30			
NDF90-CC06-D63X8-W32-L125-8	8	4	63	8	32	125	31.5	30			
NDF90-CC06-D18X9-W16-L90-2	2	1	18	9	16	90	10	16			
NDF90-CC06-D20X9-W16-L85-4	4	2	20	9	16	85	10	16			
NDF90-CC06-D23X10-W20-L90-4	4	2	23	10	20	90	12	25			
NDF90-CC06-D32X10-W25-L100-4	4	2	32	10	25	100	16	25			
NDF90-CC06-D45X10-W32-L120-6	6	3	45	10	32	120	20	25			
NDF90-CC06-D25X11-W25-L100-4	4	2	25	11	25	100	13	20			
NDF90-CC09-D30X12-W25-L100-4	4	2	30	12	25	100	16	25	CC..09T3..	TDA-047	LLT-15
NDF90-CC09-D32X12-W25-L100-2	2	1	32	12	25	100	16	25			
NDF90-CC09-D32X12-W25-L100-4	4	2	32	12	25	100	16	25			
NDF90-CC09-D32X14-W25-L100-4	4	2	32	14	25	100	16	25			
NDF90-CC09-D37X16-W32-L120-4	4	2	37	16	32	120	17	30			
NDF90-CC09-D40X17-W32-L120-4R	4	2	40	17	32	120	19	30			
NDF90-CC09-D42X17-W32-L120-4	4	2	42	17	32	120	19	30			
NDF90-CC12-D47X20-W32-L120-4	4	2	47	20	32	120	25	45	CC..1204..	TDA-081	LLT-20
NDF90-CC12-D52X21-W32-L120-4	4	2	52	21	32	120	25	45			
NDF90-CC12-D50X22-W32-L120-4	4	2	50	22	32	120	25	45			
NDF90-CC12-D55X22-W32-L120-4	4	2	55	22	32	120	2	45			

Plato de Fresado 90° - SPMG / SPGT

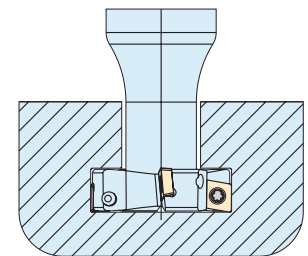
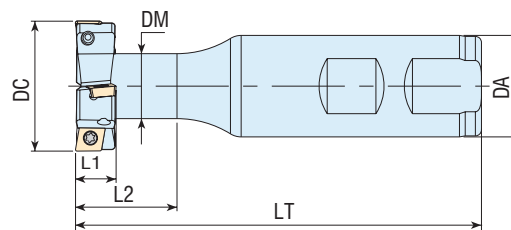

REFERENCIA	Z1	Z2	DC	L1	DA	LT	DM	L2	INSERTO	Tornillo Placa	Llave
NDF90-SP05-D22.5X5-W25-L100-4	4	2	22.5	5	25	100	12	25	SPMG050204	TDA-006	LLT-6
NDF90-SP05-D30X5-W25-L100-4	4	2	30	5	25	100	10	25			
NDF90-SPGT0502-D63X6-W32-L125-10	10	5	63	6	32	125	31	30	SPGT050204	TDA-006	LLT-6
NDF90-SPGT0904-D32X14-W32-L120-4R	4	2	32	14	32	120	17.5	30	SPGT090408	TDA-047	LLT-15
NDF90-SPGT0904-D37X16-W32-L120-4R	4	2	37	16	32	120	21	40			
NDF90-SPGT0904-D42X17-W32-L120-4R	4	2	42	17	32	120	21	40			
NDF90-SPGT1104-D47X20-W32-L120-4R	4	2	47	20	32	120	24	45	SPGT110408	TDA-066	LLT-15
NDF90-SP06-D80X7-W32-L120-10	10	5	80	7	32	120	32	30	SPMG060204	TDA-008	LLT-7

Plato de Fresado - RD..

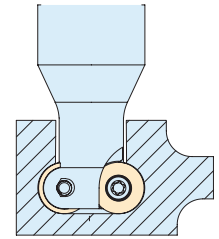
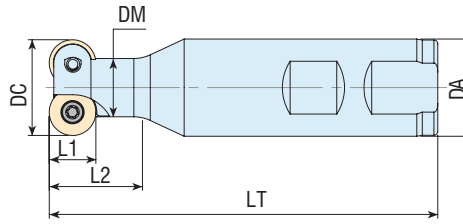

REFERENCIA	Z	DC	L1	DA	LT	DM	L2	INSERTO	Tornillo Placa	Llave
NDFR-RD0702-D17-W16-L90-2	2	17	7	16	90	10	12	RD..0702	TDA-014	LLT-8
NDFR-RD0702-D25-W16-L90-3	3	25	7	16	90	15	12			
NDFR-RD0702-D35-W25-L100-5	5	35	7	25	100	20	20			
NDFR-RD1003-D21-W25-L100-2	2	21	10	25	100	12	20	RD..1003	TDA-047	LLT-15
NDFR-RD1003-D80-W32-L165-6R	6	80	10	32	165	30	31.5			
NDFR-RD12T3-D25-W25-L100-2	2	25	12	25	100	15	24	RD..12T3	TDA-047	LLT-15
NDFR-RD12T3-D80-W32-L165-6R	6	80	12	32	165	30	31.5			
NDFR-RD1604-D34-W32-L110-2	2	34	16	32	110	20	30	RD..1604	TDA-077	LLT-15

Disco de Fresado 90° - SPGT

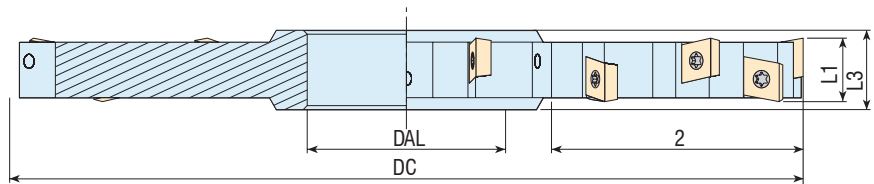

REFERENCIA	Z	Z2	DC	L1	L2	DA	L3	INSERTO	Tornillo Placa	Llave
NDDF-SPGT05-D80x6-D27-10	10	5	80	6	17	27	10	SPGT050204	TDA-006	LLT-6
NDDF-SPGT05-D100x6-D32-12	12	6	100	6	25	32	10			
NDDF-SPGT05-D125x6-D40-14	14	7	125	6	35	40	10			
NDDF-SPGT05-D160x6-D40-Z18	18	9	160	6	52	40	10			
NDDF-SPGT06-D80x7-D27-10	10	5	80	7	17	27	11	SPGT060204	TDA-008	80-T07
NDDF-SPGT06-D100x7-D32-12	12	6	100	7	25	32	11			
NDDF-SPGT06-D125x7-D40-14	14	7	125	7	35	40	11			
NDDF-SPGT06-D160x7-D40-16	16	8	160	7	52	40	11			
NDDF-SPGT06-D200x7-D40-18	18	9	200	7	70	40	11			
NDDF-SPGT07-D100x10-D32-12	12	6	100	10	25	32	11	SPGT07T308	TDA-014	LLT-8

Disco de Fresado 90° - SPGT

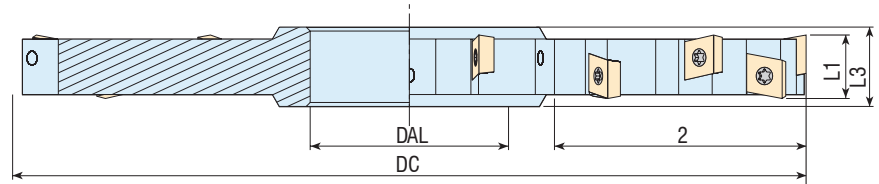

REFERENCIA	Z	Z2	DC	L1	L2	DA	L3	INSERTO	Tornillo Placa	Llave
NDDF-CC06-D80x8-D27-10	10	5	80	8	17	27	12	CC..0602	TDA-014	LLT-8
NDDF-CC06-D100x8-D32-12	12	6	100	8	25	32	12			
NDDF-CC06-D125x8-D40-14	14	7	125	8	35	40	12			
NDDF-CC06-D160x8-D40-16	16	8	160	8	52	40	12			
NDDF-CC06-D200x8-D40-Z18	18	9	200	8	70	40	12			
NDDF-CC06-D80x10-D27-10	10	5	80	10	17	27	14			
NDDF-CC06-D100x10-D32-12	12	6	100	10	25	32	14			
NDDF-CC06-D125x10-D40-14	14	7	125	10	35	40	14			
NDDF-CC06-D160x10-D40-16	16	8	160	10	52	40	14			
NDDF-CC06-D200x10-D40-18	18	9	200	10	70	40	14			
NDDF-CC09-D80x12-D27-8	8	4	80	12	17	27	16	CC..09T3	TDA-049	LLT-15
NDDF-CC09-D100x12-D32-10	10	5	100	12	25	32	16			
NDDF-CC09-D125x12-D40-12	12	6	125	12	35	40	16			
NDDF-CC09-D160x12-D40-14	14	7	160	12	52	40	16			
NDDF-CC09-D200x12-D40-16	16	8	200	12	70	40	16			
NDDF-CC09-D80x14-D27-8	8	4	80	14	17	27	18			
NDDF-CC09-D100x14-D32-10	10	5	100	14	25	32	18			
NDDF-CC09-D125x14-D40-12	12	6	125	14	35	40	18			
NDDF-CC09-D160x14-D40-14	14	7	160	14	52	40	18			
NDDF-CC09-D200x14-D40-16	16	8	200	14	70	40	18			
NDDF-CC12-D80x16-D27-6	6	3	80	16	17	27	20	CC.1204	TDA-081	LLT-20
NDDF-CC12-D100x16-D32-8	8	4	100	16	25	32	20			
NDDF-CC12-D125x16-D40-10	10	5	125	16	35	40	20			
NDDF-CC12-D160x16-D40-12	12	6	160	16	52	40	20			
NDDF-CC12-D200x16-D40-14	14	7	200	16	70	40	20			
NDDF-CC12-D80x18-D27-6	6	3	80	18	17	27	22			
NDDF-CC12-D100x18-D32-8	8	4	100	18	25	32	22			
NDDF-CC12-D125x18-D40-10	10	5	125	18	35	40	22			
NDDF-CC12-D160x18-D40-12	12	6	160	18	52	40	22			
NDDF-CC12-D200x18-D40-14	14	7	200	18	70	40	22			
NDDF-CC12-D250x18-D40-16	16	8	250	18	90	40	22			
NDDF-CC12-D80x20-D27-6	6	3	80	20	17	27	24			
NDDF-CC12-D100x20-D32-8	8	4	100	20	25	32	24			
NDDF-CC12-D125x20-D40-10	10	5	125	20	35	40	24			
NDDF-CC12-D160x20-D40-12	12	6	160	20	52	40	24			
NDDF-CC12-D200x20-D40-14	14	7	200	20	70	40	24			
NDDF-CC12-D250x20-D40-16	16	8	250	20	90	40	24			